

Manufacturer:

L I N E T spol. s r.o.
Želevčice 5
274 01 Slaný

Tel.: +420 312 576 111
Fax: +420 312 522 668

E-mail: info@linet.cz
<http://www.linet.com>
Service department: service@linetgroup.com

OptiCare X

Integrated mattress system for Multicare X

Author: LINET, s.r.o.
Related links: www.linet.com

D9U003VSX-0101

Version: 02
Publication Date: 2023-09

Copyright © L I N E T, s.r.o., 2023
Translation © L I N E T, s.r.o., 2023
All rights reserved.

All trademarks and brands are the property of the appropriate owners. The manufacturer reserves the right to changes in the contents of the instructions for use that relate to the product's technical regulations. It is for this reason that the contents of the instructions for use may indicate differences from the current manufacture of the product. Reproduction, also excerpts, only with prior permission of the publisher. Subject to changes due to technical developments. All technical data are rated data and are subject to construction and manufacturing tolerances.

Table of Contents

1 Symbols and Definitions	4
1.1 Warning Notices	4
1.1.1 Types of Warning Notices	4
1.1.2 Structure of Warning Notices	4
1.2 Instructions	4
1.3 Lists	4
1.4 Symbols on the Package (OptiCare X)	5
1.5 Symbols and Labels on the Mattress (OptiCare X)	6
1.6 Serial Labels with UDI (OptiCare X)	9
1.6.1 Serial Label for OptiCare X (SCU and mattress)	9
1.6.2 Wash Label (mattress)	9
1.7 Acoustic signalisation (OptiCare X)	10
1.8 Abbreviations	11
1.9 Definitions	11
2 Safety Instructions (only OptiCare X for Multicare X)	12
3 Intended use of OptiCare X	15
3.1 Indications	15
3.2 User population of OptiCare X	15
3.3 Contraindications	15
3.4 Operator	15
4 Product Description (OptiCare X)	16
4.1 Mattress Structure	18
4.2 Cover	18
4.3 Bottom Deck	18
4.4 Heel Section	18
4.5 Safety Straps	18
4.6 Transport Handles	19
4.7 SCU (System Control Unit)	19
4.7.1 FIRMWARE	19
5 Technical Specification (OptiCare X)	20
5.1 Mechanical Specifications	20
5.2 Electrical Specifications	20
5.3 Environment Conditions	21
5.4 Electromagnetic Compatibility	21
5.4.1 Manufacturer Instructions - Electromagnetic Emissions	21
5.4.2 Manufacturer Instructions - Electromagnetic Susceptibility	22
6 Use and Storage Conditions (OptiCare X)	23
6.1 Storage	23
7 Scope of Delivery and Product Variants (OptiCare X)	23
7.1 Delivery	23
7.2 Scope of Delivery	23
8 Putting into Service (only OptiCare X for Multicare X)	24
8.1 SCU (System Control Unit)	26
8.2 Replacing the Mattress	26
9 Manipulation (OptiCare X for Multicare X)	27
9.1 Manual CPR (during Transport or Power Loss)	28
9.2 Automatic CPR (Multicare X with OptiCare X)	29
9.3 Integrated Mattress Screen (Multicare X with OptiCare X)	31
9.4 OptiCare X Mattress Controls (Multicare X with OptiCare X)	32
9.4.1 MATTRESS DISCONNECTED	32
9.4.2 MATTRESS IDENTIFICATION	33
9.4.3 MATTRESS INFLATION	33
9.4.4 OPTIMIZE MODE	34
9.4.5 MICROCLIMATE MANAGEMENT	37
9.4.6 MOBILE MODE	38
9.4.7 PRONE MODE	39
9.4.8 MAX MODE	41
9.4.9 CPR MODE (CPR ACTIVATED)	42
9.4.10 PUMP DISCONNECTED	43
9.4.11 AUTOMATIC PRESSURE ADJUSTMENT ERROR	44
9.4.12 SCU LOG OUT	45
9.4.13 STATUSES (Multiboard X - LCD touchscreen)	46
9.5 Fault Codes (OptiCare X integrated mattress)	49
10 Equipment	50
10.1 X-ray Pocket	50
11 Cleaning/Disinfection (OptiCare X)	51
11.1 Routine Cleaning and Disinfection	52
11.2 Full Cleaning and Disinfection	52
11.3 Removing the Mattress Cover	53
12 Troubleshooting (OptiCare X)	53
13 Maintenance (OptiCare X)	57
13.1 Regular maintenance	57
13.2 Spare Parts	57
13.3 Safety Technical Checks	57
14 Disposal (OptiCare X)	58
14.1 Environment Protection	58
14.2 Disposal	58
14.2.1 Within Europe	58
14.2.2 Outside Europe	58
15 Warranty (OptiCare X)	59
16 Standards and Regulations (OptiCare X)	59

1 Symbols and Definitions

1.1 Warning Notices

1.1.1 Types of Warning Notices

Warning notices are differentiated by the type of danger using the following signal words:

- ▶ **CAUTION** warns about the risk of material damage.
- ▶ **WARNING** warns about the risk of physical injury.
- ▶ **DANGER** warns about the risk of fatal injury.

1.1.2 Structure of Warning Notices



SIGNAL WORDS!

Type and source of danger!

- ▶ Measures to avoid the danger.

1.2 Instructions

Structure of instructions:







- ▶ Perform this step.
- Results, if necessary.

1.3 Lists

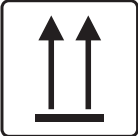

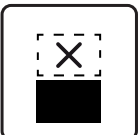







Structure of bulleted lists:

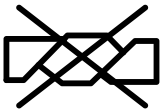







- List level 1
 - List level 2
 - List level 3



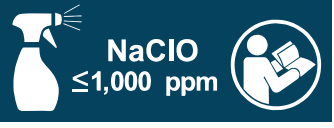







1.4 Symbols on the Package (OptiCare X)



	<p>FRAGILE, HANDLE WITH CARE</p>
	<p>THIS WAY UP</p>
	<p>KEEP DRY (PROTECT FROM HUMIDITY)</p>
	<p>PAPER RECYCLING SYMBOL</p>
	<p>DO NOT STACK DURING STORAGE</p>
	<p>DO NOT USE HAND TRUCK HERE</p>
	<p>OVERSEAS PACKAGE: STACKING LIMIT BY NUMBER (3 PACKAGES FOR TRANSPORT)</p>
	<p>OVERSEAS PACKAGE: STACKING LIMIT BY NUMBER (5 PACKAGES FOR STORAGE)</p>
	<p>RECYCLING SYMBOL</p>

1.5 Symbols and Labels on the Mattress (OptiCare X)

	<p>DO NOT IRON!</p>
	<p>DO NOT USE PHENOL!</p>
	<p>DO NOT WRING!</p>
	<p>REGULARLY INSPECT THE INSIDE OF THE COVER FOR CONTAMINATION</p>
	<p>MACHINE WASH AT MAX. 71°C FOR 3 MINUTES</p>
	<p>TUMBLE DRY ON LOW HEAT SETTING (MAX. 60°C)</p>
	<p>HANDWASH WITH DETERGENT (INITIAL TEMPERATURE OF HOT WATER SHOULD NOT EXCEED 50°C)</p>
	<p>DISINFECT USING SOLUTION CONTAINING LESS THAN 1000 ppm OF CHLORINE (REFER TO INSTRUCTIONS FOR USE)</p>
	<p>WIPE WITH WATER</p>
	<p>DRY</p>

	<p>DO NOT USE PHENOL!</p>
	<p>HANDWASH WITH DETERGENT (INITIAL TEMPERATURE OF HOT WATER SHOULD NOT EXCEED 50°C)</p>
	<p>DISINFECT USING SOLUTION CONTAINING LESS THAN 10000 ppm OF CHLORINE (REFER TO INSTRUCTIONS FOR USE)</p>
	<p>DISINFECT USING SOLUTION CONTAINING LESS THAN 1000 ppm OF CHLORINE (REFER TO INSTRUCTIONS FOR USE)</p>
	<p>WIPE WITH WATER</p>
	<p>COVER MATERIALS ARE FIRE RESISTANT TO BS7175, SOURCE 0, 1 AND 5</p>
	<p>MATTRESS FOOT PART (OptiCare X)</p>
	<p>WEEE SYMBOL (RECYCLE AS ELECTRONIC WASTE, DO NOT PUT INTO THE HOUSEHOLD WASTE)</p>
	<p>MEDICAL DEVICE (compatible with Medical Device Regulation)</p>
	<p>MANUFACTURER</p>

	<p>MANUFACTURING DATE</p>
	<p>REFERENCE NUMBER (PRODUCT TYPE DEPENDING ON CONFIGURATION)</p>
	<p>SERIAL NUMBER</p>
	<p>ONLY SUITABLE FOR INDOOR USE</p>
	<p>APPLIED PARTS TYPE B</p>
	<p>WARNING</p>
	<p>READ INSTRUCTIONS FOR USE</p>
	<p>T1AH ANTI-SURGE FUSE (SCU FUSE)</p>
	<p>ALTERNATING CURRENT</p>
	<p>THERMAL PROTECTION FOR TRANSFORMER</p>































	<p>SAFETY ISOLATING TRANSFORMER (GENERAL)</p>
	<p>EARTH GROUND</p>
	<p>CE MARK (EUROPEAN CONFORMITY)</p>

1.6 Serial Labels with UDI (OptiCare X)

1.6.1 Serial Label for OptiCare X (SCU and mattress)

Serial label of the OptiCare X SCU is placed on the SCU under the foot board of the Multicare X bed. The serial label contains information about Address of Manufacturer, Manufacturing Date (Year-Month-Day), Product Reference Number, Product Serial Number, Global Trade Item Number (GTIN), Unique Device Identification (UDI), symbols and electrical specifications. Serial label of the OptiCare X mattress is placed at the mattress foot end. The serial label contains information about Address of Manufacturer, Manufacturing Date (Year-Month-Day), Product Reference Number, Product Serial Number, Global Trade Item Number (GTIN), Unique Device Identification (UDI) and symbols.

1.6.2 Wash Label (mattress)

<p>COVER TEXTILE(S) PASS THE REQUIREMENTS OF CIB 117:2013 SECTION 11 (CLASS 1 NONWoven and LAMINABILITY), 16 CFR Part 1532.6-2013 Edition</p> <p>BS 7175</p>  <p>www.linetek.com</p> <p>WISSNER-BOSSERHOFF</p> <p>HAZARD</p> <p>LINET spol. s r.o. Zeleňovice 5, 274 01 Slany The Czech Republic</p> <table border="1"> <tr><td>1</td><td>2</td><td>3</td><td>4</td><td>5</td><td>6</td></tr> <tr><td>7</td><td>8</td><td>9</td><td>10</td><td>11</td><td>12</td></tr> <tr><td>17</td><td>18</td><td>19</td><td>20</td><td>21</td><td>22</td></tr> </table>	1	2	3	4	5	6	7	8	9	10	11	12	17	18	19	20	21	22	<table border="1"> <tr> <td></td> <td></td> <td></td> <td></td> <td></td> </tr> <tr> <td></td> <td></td> <td></td> <td></td> <td></td> </tr> </table>										
1	2	3	4	5	6																								
7	8	9	10	11	12																								
17	18	19	20	21	22																								
																													
																													

1.7 Acoustic signalisation (OptiCare X)

SOUND	MEANING
REPEATED BEEP: 0,2s sound / 1s silence (high priority)	Overpressure Fault (fault number 5)
	Pressure Calibration Fault (fault number 94)
	Solenoid Fail (fault number 98)
	Deflation Fault During CPR (fault number 105)
REPEATED BEEP: 0,2s sound / 5s silence (medium priority)	Pressure Sensor Fault (fault number 4)
	Air Hose Disconnected (fault number 101)
	Inflate Fault (fault number 102)
	Kinked Air Hoses (fault number 107)
REPEATED BEEP: 0,2s sound / 10s silence (low priority)	Major Inflate Fault (fault number 2)
	Deflate Fault (fault number 3)
	BOD Valve Fault (fault number 6)
	Blower Fault (fault number 7)
	Clogged Blower Filter (fault number 8)
	Valve Short Circuit (fault number 14)
	Not Supported Type of Mattress (fault number 106)
	Optimization Failed (fault number 108)

1.8 Abbreviations

AC (~)	Alternating Current
BOD	Bottom Out Detector
CE	European Conformity
CPR	Cardiopulmonary Resuscitation
dB	Sound Intensity Unit
DC (---)	Direct Current
CUC	Configuration number
EMC	Electromagnetic Compatibility
FET	Field-effect transistor
HF	High Frequency
HPL	High Pressure Laminate
ICU	Intensive Care Unit
INT.	Duty Cycle
IP	Ingress Protection
IV	Intravenous
LED	Light Emitting Diodes
ME	Medical Electrical (Equipment)
ON	Activation
OFF	Deactivation
ppm	parts per million, millionth (1000 ppm = 0,1%)
REF	Reference Number (product type depending on configuration)
SCU	System Control Unit (integrated mattress)
SN	Serial Number
SW	Software
SWL	Safe Working Load
UDI	Unique Device Identification (for medical devices)
USB	Universal Serial Bus
WEEE	Waste Electrical and Electronic Equipment

1.9 Definitions

Maximum Patient Weight	The highest allowable load on the mattress.
Adult	Patient having a physical size equal to or more than 146 cm, a mass equal to or more than 40 kg and a body mass index (BMI) equal to or more than 17 (according to IEC 60601-2-52).

2 Safety Instructions (only OptiCare X for Multicare X)



WARNING!

Multicare X bed with OptiCare X integrated mattress system should be left in its lowest position when the patient is unattended in order to reduce risk of injury due to falls!



WARNING!

Siderails of the Multicare X bed should be located in the „up“ position to reduce the risk of the patient accidentally slipping or rolling off the OptiCare X integrated mattress!



WARNING!

Inappropriate handling of the Multicare X power supply cord, e. g. by kinking, shearing or other mechanical damages is hazardous!



WARNING!

When routing cables from OptiCare X integrated mattress system in the Multicare X bed avoid squeezing those cables between parts of the Multicare X bed!



WARNING!

The OptiCare X integrated mattress system with Multicare X bed are intended for adults.

- ▶ Follow the chapter **Intended use**.



WARNING!

OptiCare X integrated mattress system is compatible only with Multicare X bed. The OptiCare X integrated mattress system can only be used when installed on a LINET Multicare X bed frame.



WARNING!

To avoid the risk of electric shock, the Multicare X bed must only be connected to a supply mains with protective earth.



WARNING!

No modification of OptiCare X integrated mattress system is allowed.



WARNING!

Do not modify OptiCare X integrated mattress system without authorization of the manufacturer.



WARNING!

If OptiCare X integrated mattress system is modified, appropriate inspection and testing must be conducted to ensure continued safe use of the equipment.



WARNING!

An additional multiple socket-outlet or extension cord shall not be connected to the medical electrical system of the OptiCare X integrated mattress system with Multicare X bed.



WARNING!

OptiCare X integrated mattress system must be used exclusively by or under supervision of trained and qualified nursing personnel!



WARNING!

Staff expert assessment is needed to consider all individual cases of contraindications!

- ▶ Certain bed positions are not suitable for specific diagnosis/medical conditions. Fowler position is not suitable for spinal cord injuries! Trendelenburg position is not suitable for patients with higher intracranial pressure!



WARNING!
 Length adjustment of the Multicare X bed must be proportional to the height of patient and to the placement of the OptiCare X integrated mattress system!
 ► Risk of trapping or squeezing because of patient's body constitution disproportionate to the size of mattress support platform!



WARNING!
 During specific investigations or treatments the significant risks of reciprocal interference posed by OptiCare X integrated mattress system with Multicare X bed may occur.



WARNING!
 Any serious incident that has occurred in relation to the device (OptiCare X integrated mattress system) should be reported to the manufacturer and the competent authority of the Member State in which the user and/or patient is established!



WARNING!
 Only authorised and trained person using the tool is allowed to change fuses and power supplies of the OptiCare X integrated mattress system!



WARNING!
 This medical device (OptiCare X integrated mattress system) is not intended for oxygen enriched environment!



WARNING!
 This medical device (OptiCare X integrated mattress system) is not intended for use with flammable substances!



WARNING!
 This medical device (OptiCare X integrated mattress system) is not portable medical electrical equipment!

Additional Instructions for correct use:

- ▶ Follow the instructions for use carefully.
- ▶ Ensure any user has read and understood the instructions for use completely before operating the product.
- ▶ Use OptiCare X integrated mattress system exclusively as specified in the instructions for use and in perfect working order.
- ▶ If necessary, check the OptiCare X functions daily or at each shift change.
- ▶ Use the Multicare X bed exclusively with the correct mains supply.
- ▶ Ensure that the OptiCare X integrated mattress system is operated exclusively by qualified personnel who have been trained according to the instructions for use.
- ▶ Ensure OptiCare X integrated mattress system is operated by qualified personnel trained in using the Multicare X bed in accordance with the instructions for use by manufacturer or by person approved by the manufacturer, eventually by authorized representative or by person approved by the authorized representative.
- ▶ Ensure that the patient (health permitting) has been informed about the operation of the OptiCare X integrated mattress system and all applicable safety instructions.
- ▶ Contact service department of the manufacturer immediately to let it replace any damaged parts by the original spare parts.
- ▶ Ensure that maintenance and installation are performed exclusively by qualified personnel who have been trained by the manufacturer.
- ▶ During unavoidable excess loads (e. g. CPR), adjust bed mattress support platform with OptiCare X integrated mattress system to the lowest position.
- ▶ Ensure that only one adult patient lies on the OptiCare X mattress at any time.
- ▶ To avoid injury or crushing, take extra caution when operating any moving parts of the Multicare X bed.
- ▶ When using lifting poles or infusion stands, ensure that OptiCare X integrated mattress system will not be damaged when you move or adjust Multicare X bed.
- ▶ Keep the Mattress support platform with OptiCare X integrated mattress system in the lowest position at any time when the healthcare personnel are not treating the patient in order to prevent the patient from falling or injuries.
- ▶ Ensure that siderails of Multicare X bed are operated exclusively by healthcare personnel.
- ▶ Never handle the mains plug of Multicare X bed with wet hands.
- ▶ Disconnect Multicare X bed from the mains exclusively by pulling the mains plug.
- ▶ Disconnect Outlet Power cable from the mains exclusively by pulling the mains plug.
- ▶ When pulling the mains plug, always hold the plug, not the cable.
- ▶ Improper handling of mains cable can cause an electric shock hazard, other serious injuries or damage to OptiCare X mattress system.
- ▶ Ensure that the stipulated duty cycle of Multicare X bed is not exceeded.
- ▶ To prevent failures, use exclusively the manufacturer's original accessories.
- ▶ Ensure that the stipulated safe working load is not exceeded.
- ▶ If the patient's condition could lead to an entrapment, leave the mattress support platform with OptiCare X integrated mattress system in the flat position whilst unattended.
- ▶ Do not exceed the maximum patient weight limit of the Multicare X and of the OptiCare X integrated mattress system at the same time.
- ▶ Do not use the SCU near flammable gases. (This does not apply to oxygen cylinders.)
- ▶ Do not hang anything on any cable.
- ▶ Never use OptiCare X integrated mattress system near radiators or other heat sources.
- ▶ After each emergency situation always check if any of the Multicare X controllers (controllers in siderails, handset or Attendant Control Panel) is not involuntarily pressed by the bed accessories or by the OptiCare X integrated mattress.
- ▶ To avoid unintended activation of moving parts during any use of the bed always check that none of the control elements of the Multicare X bed is pressed by persons, by OptiCare X integrated mattress or by other objects.
- ▶ Never cover the SCU while in use.
- ▶ Never cover the filter of SCU while in use.

3 Intended use of OptiCare X

The intended purpose of this mattress is to provide a support surface for patients by pressure redistribution designed for management of tissue loads and microclimate management. This mattress is intended to be used with integrated air compressor of Multicare X LINET medical bed.

3.1 Indications

The mattress is recommended for use with patients who have been identified as having from low to very high-risk rating of pressure injuries development, (very high risk includes patients with pressure injuries in the past or currently having a pressure injury of any category) according to EPUAP/NPIAP standards for pressure injury prevention in line with local policy and guidelines.

The use of the mattress does not remove the need for regular repositioning of patients in line with best clinical practice.

NOTE: A full risk assessment of the patient's risk of a pressure injury development must be carried out by an appropriately trained clinician and clinical judgement must be made to identify the suitability of the product for use with the patient.

3.2 User population of OptiCare X

- ▶ Adult patients (weight \geq 40 kg, height \geq 146 cm, BMI \geq 17)
- ▶ Application Environment 1 (ICU) and 2 (Acute care), as in IEC 60601-2-52

3.3 Contraindications

Mattress system is contraindicated for patients:

1. with cervical or skeletal traction
2. with unstable skeletal fractures
3. with unstable spinal fractures
4. exceeding maximum patient weight of the mattress

Other contraindications may be identified on an individual patient basis depending on clinical risk assessment.

NOTE: For patients in prone position - before placing the patient into prone position a detailed clinical risk assessment should be carried out by an appropriately trained clinician.

3.4 Operator

- ▶ Caregivers (nurses/doctors) that are fully trained in use of the mattress. Operators must familiarize themselves with all warnings and cautions contained in the instructions for use before use of the mattress. Clinical risk assessment should be carried out by appropriately trained staff and clinical judgement should be made to ascertain that the product is suitable for meeting the care needs of the individual patient.
- ▶ Technical, transport and cleaning personnel should be fully trained in the maintenance and service of the product and must familiarize themselves with all warnings and cautions contained in the instructions for use.

4 Product Description (OptiCare X)

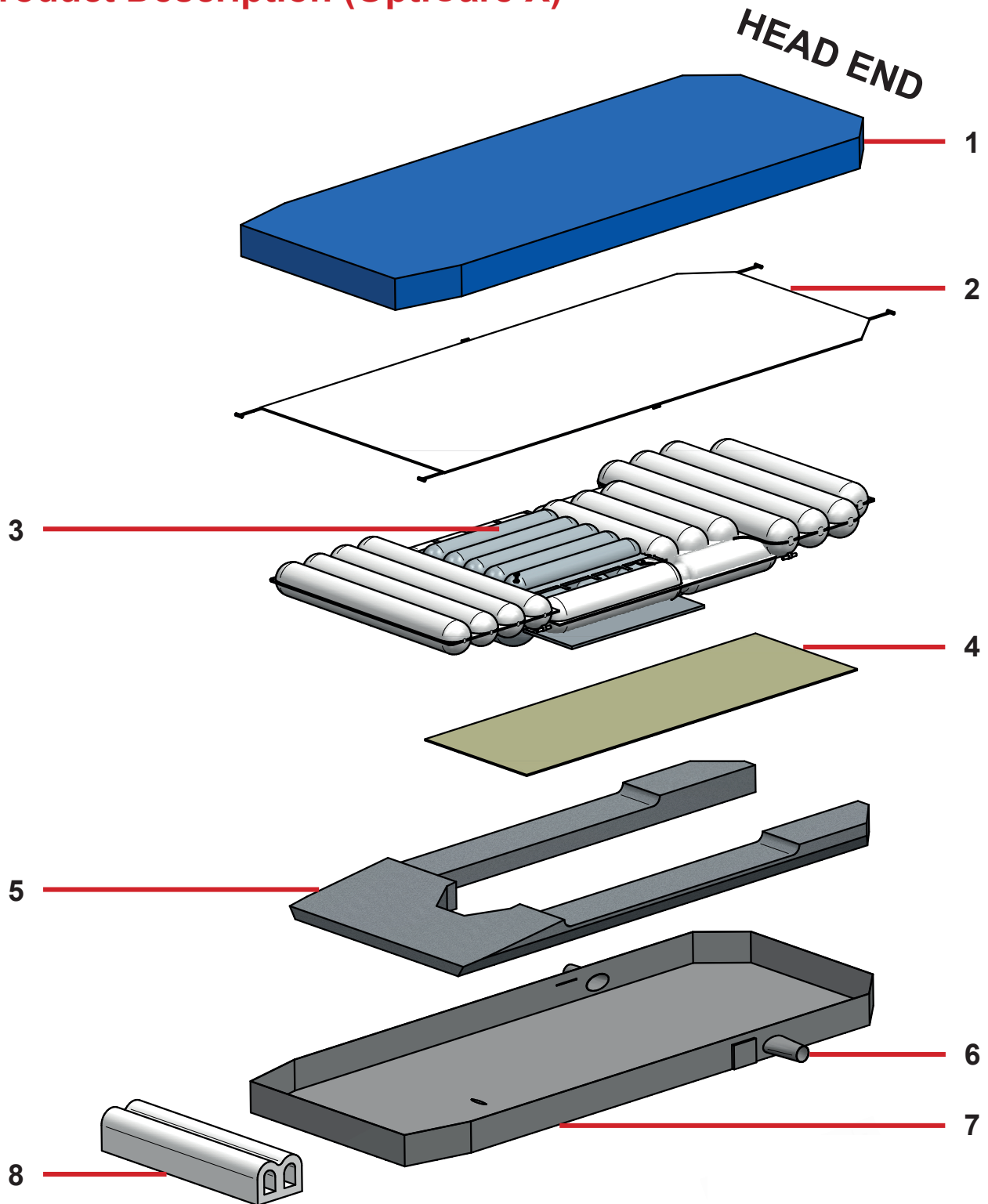

Fig. OptiCare X Mattress Description

1. Cover
2. Comfort Layer
3. Air Cell Sets
4. Plastazote Foam Base
5. Foam Base
6. CPR Valve
7. Base Cover
8. Heel Section

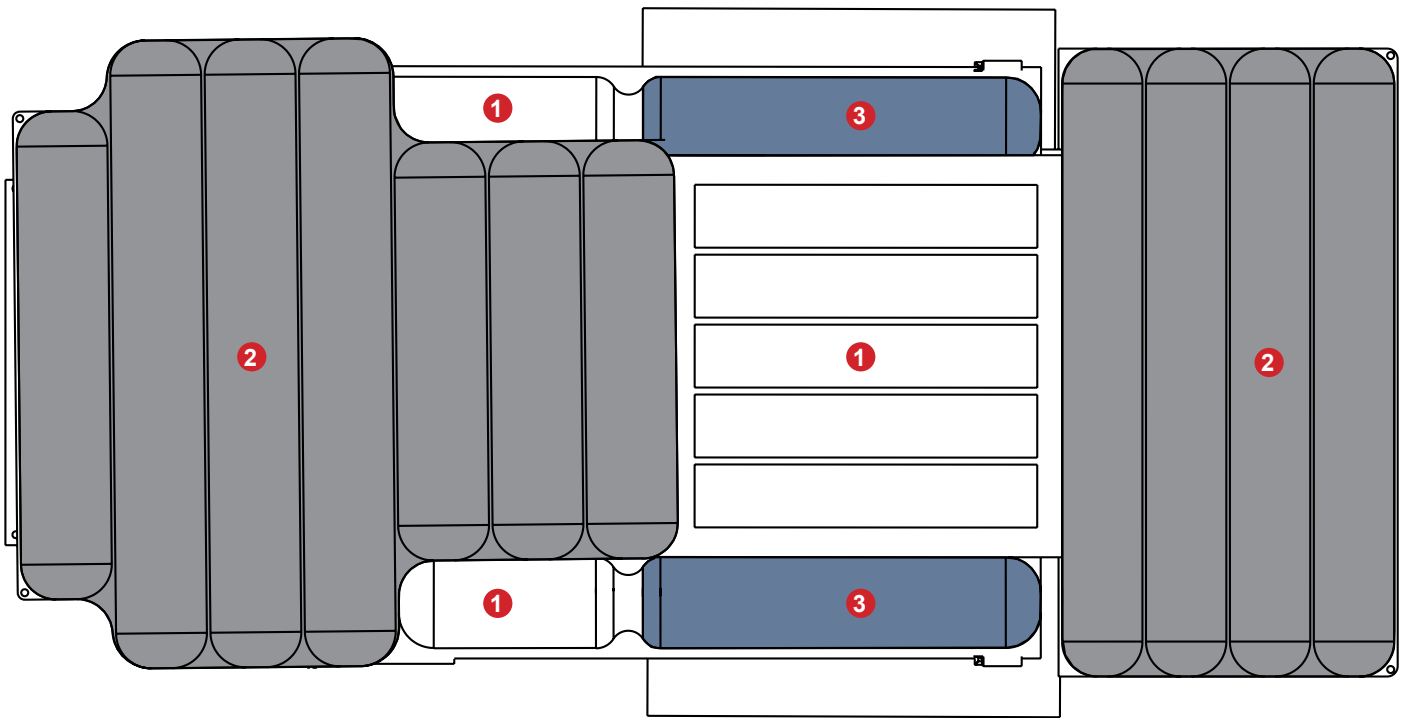

Fig. Structure of the Air Cell Sets (top view)

- 1. Area A (WHITE CELLS)
- 2. Area B (GREY CELLS)
- 3. Area S (BLUE CELLS)

4.1 Mattress Structure

The OptiCare X mattress consists of 4 sections that are held together by 6 quick release fixation toggles. The 3 sections include cover, comfort layer, air cell set and foam base which supports the leg section and side formers. Within the central cut-out of the foam base is a 10 mm high density foam sheet to protect the patient if the mattress is deflated. Air cell set is divided into Area A and Area B. A two-part cover (1) made of water resistant vapour permeable material encloses the mattress. Beneath the cover and on the top of the upper air layer is a removable polyester comfort layer (2). The 2 air layers consist of 10 separate air modules for easy and cost effective replacement in case of user damage. 7 of these air modules are connected together to form the Constant Low Pressure air mattress, while the other 3 act as air manifolds for the MICROCLIMATE Management (MCM) function. The mattress has a 7 degree heel slope to help further off-loading of pressure in the vulnerable heel area.

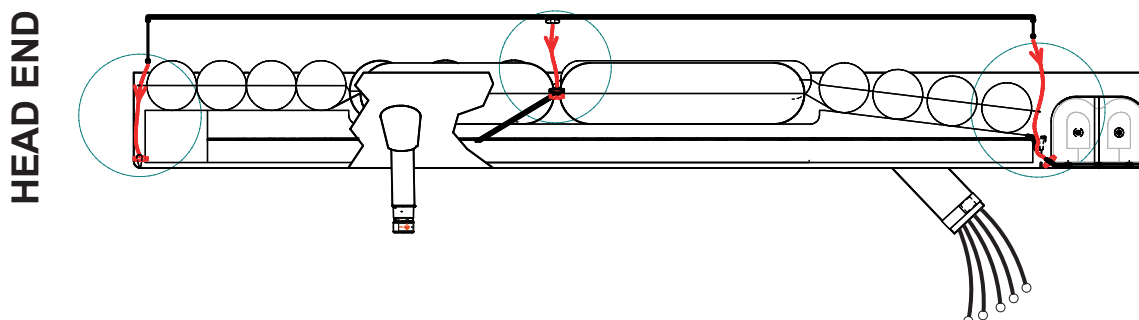

Fig. Fixation of Comfort Layer to the cells (Fixation toggles)

4.2 Cover

The top part of the cover consists of highly moisture- and vapour-permeable (MVP) two-way stretch material which forms an integral part of the MICROCLIMATE Management (MCM) function. The cover top is equipped with a full 360-degree zip to allow easy removal for cleaning or replacement. The zip is covered by a waterproof flap to protect the mattress against fluid ingress. The cover base is made from water-impermeable high-strength non-stretch material that is suitable for any demanding environment. Additional quick-release straps prevent the mattress from shifting if the head board or foot board is removed. Optional ZONED Cover is characterized by the middle slippery zone on its surface.

4.3 Bottom Deck

The bottom air layer is enclosed by a foam base fully contained within a removable waterproof cover. This provides support for the patient when entering or exiting the bed. The angled sides of the foam base are designed to fit securely into the shaped sides of the Multicare X patient platform to prevent any movement of the mattress when the patient is getting into or out of the bed.

4.4 Heel Section

The heel section is made up of 2 foam in air cells each with a custom designed internal foam shape that allows the 2 cells to collapse back into a reduced shape when pressed in by the foot board of the bedframe. This reduces the length of the mattress by 190 mm when compressed. The heel cells will self inflate when the bed is lengthened.

4.5 Safety Straps

The sides of the foam base fit the sides of the Multicare X mattress support platform to prevent the mattress from shifting when the patient is getting into or out of bed.

The mattress is equipped with additional quick-release straps to prevent the mattress from shifting if the head or foot board is removed. These straps are located on head end and foot end of the bed.

To fix the strap:

- ▶ Loop black strap around metal bed frame and feed it back through the plastic clip.

To release the strap:

- ▶ Pull loose end of strap upward to release clip.

4.6 Transport Handles



WARNING!

Material damage and risk of injury due to incorrect use!

- ▶ Transport the mattress using transport handles without patient on it!

Transport handles are intended for transport of the mattress only.

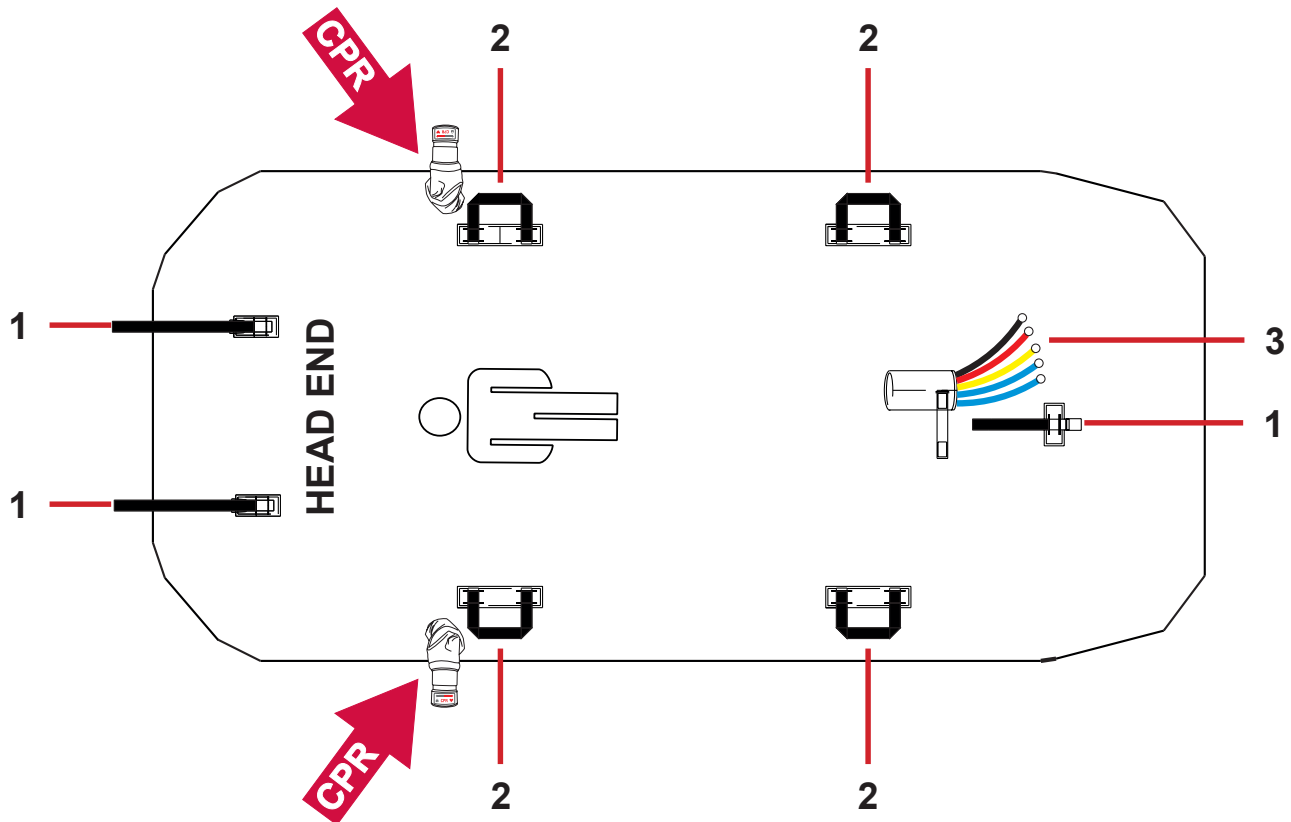

Fig. Base Cover Description

- 1. Safety Straps (to fix mattress on the Mattress Platform)
- 2. Transport Handles
- 3. Aip Pipes

4.7 SCU (System Control Unit)

The SCU (System Control Unit) is installed under the leg section of the bed frame. It is possible to have the Multicare X bed delivered with the SCU factory-fitted, or to have it retrofitted by approved service personnel. OptiCare X ready Multicare X bed is equipped with a dedicated power outlet for the SCU at the auxiliary power distribution point. The SCU is operated via the Integrated Mattress Screen on the Multiboard X LCD touchscreen. There is no ON/OFF switch on SCU. The SCU is equipped with a comprehensive alarm system which detects any problems with the system performance.

The alarm system

- ▶ Gives audible and visual alarms via the Multiboard X if a problem requires immediate action.
- ▶ Stores information for the service personnel to review later.

4.7.1 FIRMWARE

The system control unit includes firmware that can be updated only by an authorised service technician.

This firmware is protected against unauthorised access by mechanical housing (tool is needed to access) and by exclusive compatibility with an authorised software tool and specific cable.

5 Technical Specification (OptiCare X)

All technical data are rated data and are subject to construction and manufacturing tolerances.



WARNING!

If Multicare X bed is used with OptiCare X integrated mattress system, respect values of mechanical and electrical specifications which can harm none of them!

5.1 Mechanical Specifications

Parameter	Value
External dimensions of Inflated Mattress (length x width x height)	214 cm x 87 cm x 23 cm
Length of the Integrated Mattress Extension	19 cm
Dimensions of the X-ray Pocket (length x width)	90 cm x 92 cm
External dimensions of SCU	36 cm x 22 cm x 10 cm
Weight of Inflated Mattress	14 kg (31 lbs)
Weight of SCU	6 kg (13.1 lbs)
Inflation time after storage	max. 10 min
CPR deflation time (depending on patient weight, chosen mode - optimization or maximum internal pressure - and on type of CPR - electric or manual)	max. 30 s
Remain Inflated in Transport Mode	12 hours (when starting from Maximum Inflate Mode)
Sound Pressure Level	max. 46 dBA (normal operation without any sounding alert signal)
Maximum Patient Weight	250 kg (551 lbs)
Minimum Mattress Load	40 kg
Maximum Washing Temperature of the mattress cover ELITE (MIC200)	71°C
Maximum Washing Temperature of the mattress cover ENDURANCE (SIOEN RP9774-2)	71°C
Maximum Washing Temperature of the mattress cover ZONED (DARTEX)	55°C
Maximum Drying Temperature of the mattress cover ELITE (MIC200)	55°C
Maximum Drying Temperature of the mattress cover ENDURANCE (SIOEN RP9774-2)	55°C
Maximum Drying Temperature of the mattress cover ZONED (DARTEX)	55°C
Fire Resistance of the Cover	according to BS7175 - ignition source 5
Fire Resistance of the Top Cover	according to 16 CFR 1632
Fire Resistance of the whole mattress	according to BS7177 - ignition source 5, 16 CFR 1632

5.2 Electrical Specifications

Parameter	Value
Input Voltage, Frequency: EU version USA version Brazilian version	220-240 V AC, 50/60 Hz 100-127 V AC, 50/60 Hz 220 V AC, 60 Hz
Maximum Power Input	max. 40 VA (when operating from mains supply)
Ingress Protection (EN 60529)	IPX4
Protection Class	Class I with Applied Parts Type B
Electrical Safety	in conformity with EN 60601-1
SCU Fuse 220-240 V AC version 100-127 V AC version	2 x T0,5AH Anti-surge Fuse 2 x T1AH Anti-surge Fuse

5.3 Environment Conditions

Use Conditions	
Ambient Temperature	10°C - 40°C
Relative Humidity	30% - 75 %
Atmospheric Pressure	795 - 1060 hPa
Storage and Transport Conditions	
Ambient Temperature	-40°C - 70°C
Relative Humidity	10% - 100 % (non-condensing)
Atmospheric Pressure	795 - 1060 hPa

5.4 Electromagnetic Compatibility

OptiCare X integrated mattress system is intended for hospitals except for near active HF surgical equipment and the RF shielded room of a medical system for magnetic resonance imaging, where the intensity of EM disturbances is high.

OptiCare X integrated mattress system has defined no essential performance.



WARNING!

It is recommended to avoid the use of this device next to or in block with other device, because it could lead to improper operation. If such use is needed, this device and the other equipment should be under surveillance to verify proper operation. (Does not apply for compatible medical bed from LINET)

List of used cables:

- ▶ **Mains cable**, maximum length 6 m



WARNING!

Use of the accessories, converters and other cables, than specified and provided by manufacturer of this OptiCare X integrated mattress system could lead to increase of electromagnetic emission or lower the electromagnetic immunity of this OptiCare X integrated mattress system and lead to improper operation.



WARNING!

Mobile RF communication device (including end use devices like antenna cables and external antenna) should not be used closer than 30 cm (12 inches) from any part of this OptiCare X integrated mattress system, including cables specified by manufacturer. Otherwise this could lead to deterioration of functionality of this OptiCare X integrated mattress system.



WARNING!

Do not overload the OptiCare X integrated mattress system (SWL), respect the duty cycle (INT.) and consider chapter 13 Maintenance in order to maintain the basic safety with regard to electromagnetic disturbances for the expected service life.

5.4.1 Manufacturer Instructions - Electromagnetic Emissions

Emission Test	Compliance
RF emissions CISPR 11	Group 1
RF emissions CISPR 11	Class B
Harmonic emissions IEC 61000-3-2	Class A
Voltage fluctuations / flicker emissions IEC 61000-3-3	Complies

5.4.2 Manufacturer Instructions - Electromagnetic Susceptibility

Immunity Tests	Compliance level
Electrostatic discharge (ESD) IEC 61000-4-2	± 8 kV for contact discharge ± 15 kV for air discharge
Radiated RF IEC 61000-4-3	3 V/m 80 MHz – 2,7 GHz 80 % AM at 1 kHz
Proximity fields from RF wireless communications equipment IEC 61000-4-3	See Table 1
Fast electrical transients / burst IEC 61000-4-4	±2 kV for power line repetition frequency 100 kHz
Surge IEC 61000-4-5	± 1 kV Line-to-line ± 2 kV Line-to-ground
Conducted RF IEC 61000-4-6	3 V (0,15 MHz – 80 MHz) 6 V in ISM bands between 0,15 MHz and 80 MHz 80 % AM at 1 kHz
Power frequency (50/60 Hz) magnetic field IEC 61000-4-8	30 A/m
Voltage dips, short interruptions on power supply input lines IEC 61000-4-11	0 % UT; 0,5 cycle At 0°, 45°, 90°, 135°, 180°, 225°, 270° a 315° 0 % UT; 1 cycle and 70 % UT; 25/30 cycle Single phase: at 0° 0 % UT; 250/300 cycle

Table 1 - IMMUNITY to RF wireless communications equipment

Test frequency (MHz)	Band (MHz)	Service	Modulation	Immunity Test Level V/m
385	380 - 390	TETRA 400	Pulse modulation 18 Hz	27
450	430 - 470	GMRS 460, FRS 460	FM ± 5 kHz deviation 1 kHz sine	28
710 745 780	704 - 787	LTE band 13, 17	Pulse modulation 217 Hz	9
810 870 930	800 - 960	GSM 800/900, TETRA 800, iDEN 820, CDMA 850, LTE band 5	Pulse modulation 18 Hz	28
1 720 1 845 1 970	1 700 - 1 990	GSM 1800; CDMA 1900; GSM 1900; DECT; LTE band 1, 3, 4, 25; UMTS	Pulse modulation 217 Hz	28
2 450	2 400 - 2 570	Bluetooth, WLAN, 802.11 b/g/n, RFID 2450, LTE band 7	Pulse modulation 217 Hz	28
5 240 5 500 5 785	5 100 - 5 800	WLAN 802.11 a/n	Pulse modulation 217 Hz	9

NOTE There are applied no deviations to requirements of IEC 60601-1-2 ed. 4

NOTE There are no known other measures for keeping the basic safety based on EMC phenomena.

6 Use and Storage Conditions (OptiCare X)



DANGER!

Danger to life due to electric shock!

To ensure the bed's class I protection against electric shocks:

- ▶ Ground the mains.
- ▶ Use exclusively Hospital Grade or Hospital Only receptacles for grounding.

Multicare X with OptiCare X integrated mattress system is designed for use in rooms for medical purposes. Electrical installations must therefore meet local norms laying down the necessary conditions for electrical installations.

- ▶ Disconnect the bed from the mains in exceptional cases (i.e. lightnings, earthquake).

OptiCare X integrated mattress system is not suitable for indoor environments containing flammable gases (except oxygen cylinders).

6.1 Storage

When SCU is not in use:

- ▶ Log off the mattress.
- ▶ Unplug mains cable.

When mattress is not in use:

- ▶ Unclip all 5 air pipes.
- ▶ Undo webbing strap next to air pipes.
- ▶ Make sure mattress has been cleaned and is completely dry inside and out (see Cleaning/Disinfection).
- ▶ Deflate mattress and leave air connector open (CPR position).
- ▶ Roll mattress up carefully to get air out completely.

Store in a dry and safe place and keep away from sharp objects.

7 Scope of Delivery and Product Variants (OptiCare X)

7.1 Delivery

- ▶ Upon receipt, check that the shipment is complete as specified on the delivery note.
- ▶ Notify the carrier and supplier of any deficiencies or damages immediately as well as in writing or make a note on the delivery note.

7.2 Scope of Delivery

- OptiCare X integrated mattress
- Mattress Cover
 - ELITE
 - ENDURANCE
 - with X-ray Pocket
 - without X-ray Pocket
 - ZONED
 - with X-ray Pocket
 - without X-ray Pocket
- SCU (System Control Unit)
- Instructions for use

8 Putting into Service (only OptiCare X for Multicare X)



WARNING!

Risk of injury when working on the OptiCare X integrated mattress system!

- ▶ Ensure that the Multicare X bed is disconnected from the mains connection prior to putting OptiCare X integrated mattress system into service, putting it out of service and maintenance.
- ▶ Ensure that the castors are locked prior to putting OptiCare X integrated mattress system into service, putting out of service and maintenance.



CAUTION!

Material damage due to incorrect putting into service!

- ▶ Ensure that putting into service is performed exclusively by manufacturer's customer service or trained hospital personnel.

The OptiCare X mattress system replaces any mattress on the Multicare X bed frame.

- ▶ Remove any existing mattress.
- ▶ Put mattress on the Mattress support platform with air pipes at foot end of the bed.
- ▶ Connect Air Pipes to SCU observing colour code.
- ▶ Make sure that the CPR valves on both sides of the head end of the mattress are not left open but connected and accessible to manipulation.

NOTE During first installation of the mattress CPR valve is open!

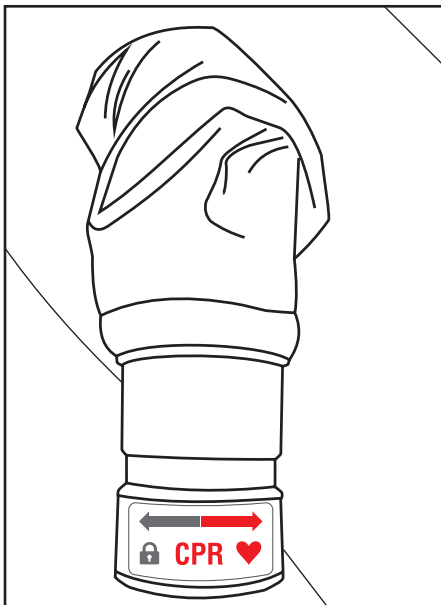

Fig. Closed CPR valve

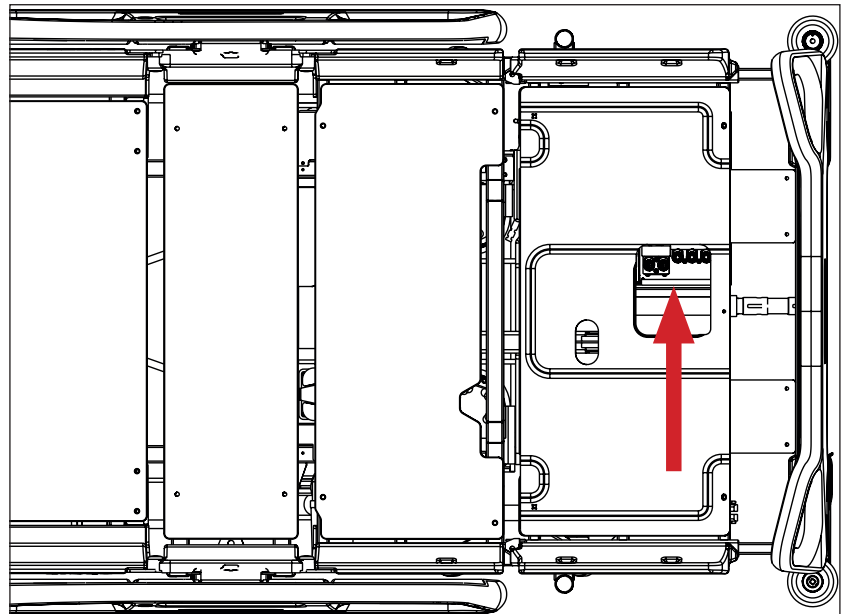

Fig. SCU with Air Pipe Connectors (foot end of the Multicare X bed)

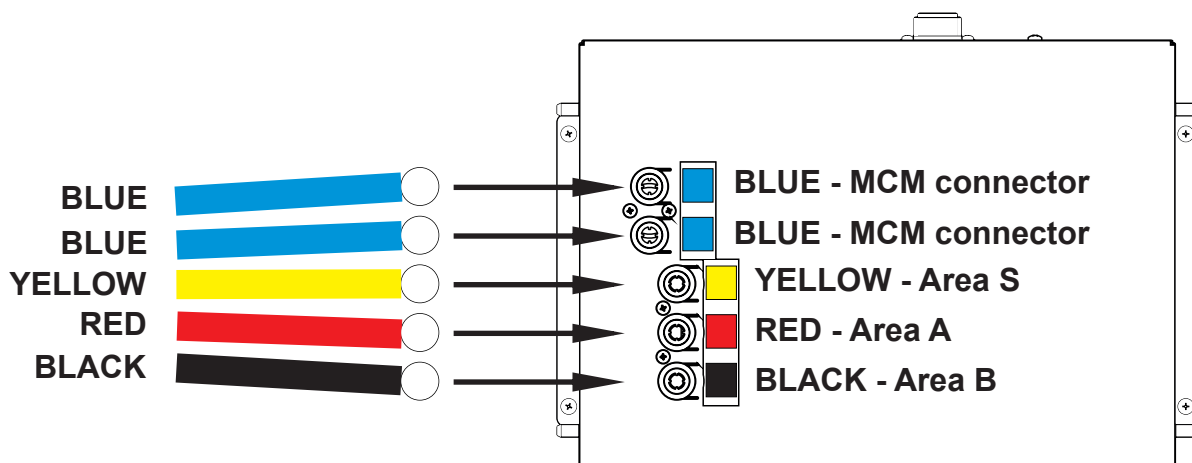

Fig. Air Pipes and SCU with Air Pipe Connectors

Mattress Detection System (MDS)

Sensors in the System Control Unit (SCU) Area A, B and ODV mattress air connectors detect that a valid air connector has been connected. When all three correct air connectors are detected, the SCU will enter Standby Mode. In Standby Mode mattress areas A and B are inflated to a static pressure ready for a patient to be placed onto the mattress and Optimization to start.

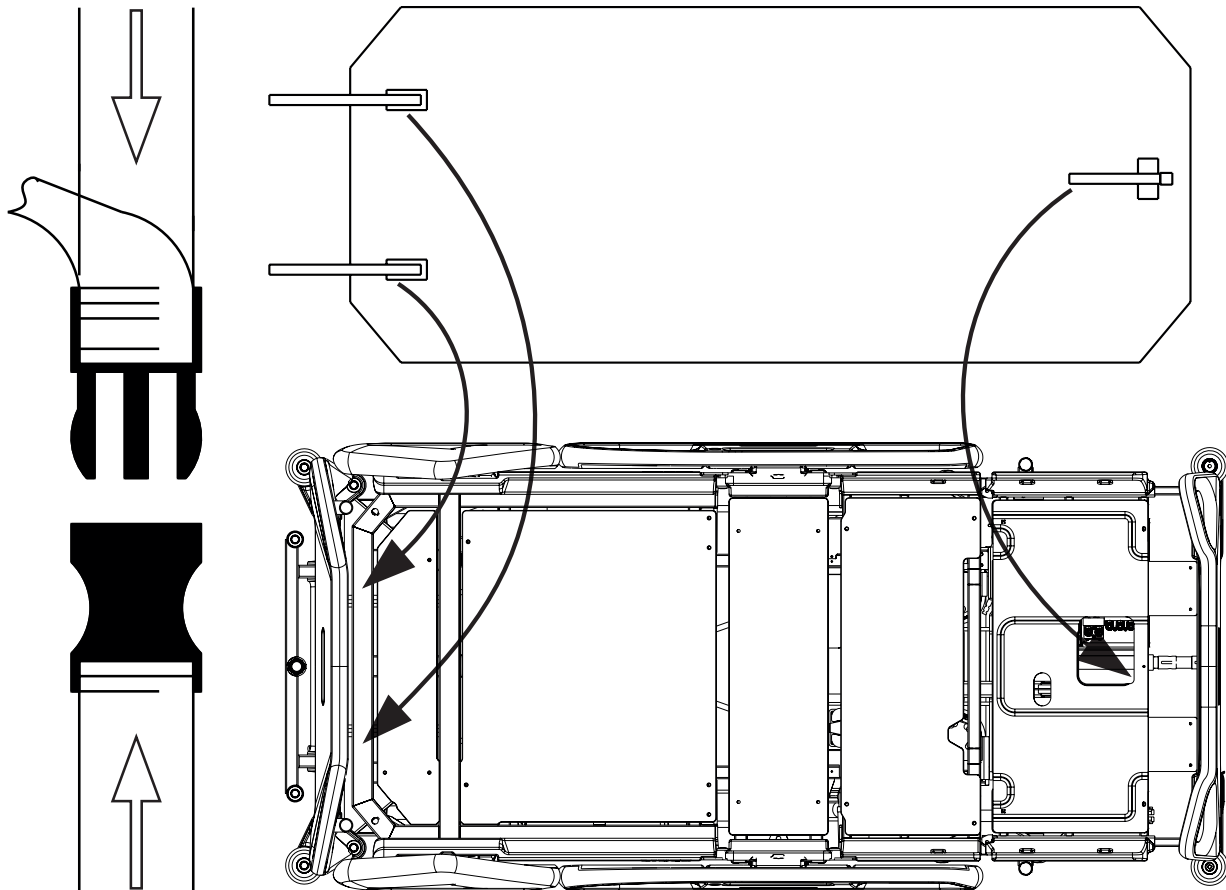

Fig. Fixation of the mattress with straps on the mattress support platform of Multicare X bed

8.1 SCU (System Control Unit)



WARNING!

OptiCare X mattress is compatible with System Control Unit delivered by manufacturer only!

- ▶ Do not use any other System Control Unit with OptiCare X mattress!



CAUTION!

Material damage due to incorrect installation of SCU!

- ▶ If the SCU does not come factory-fitted, have it installed by a service engineer authorised by LINET ®.

8.2 Replacing the Mattress

If replacing the OptiCare X mattress with another mattress replacement system, then you will need to cancel the Mattress Not Connected alarm and log out the OptiCare X mattress.

To log out OptiCare X mattress:

- ▶ press MATTRESS LOG OUT Icon.



Fig. MATTRESS LOG OUT Icon (Multiboard X LCD touchscreen)

9 Manipulation (OptiCare X for Multicare X)

Preparing OptiCare X for Patient



DANGER!

Risk of suffocation due to air-impermeable mattress cover!

- ▶ Use mattress cover correctly.
- ▶ The nursing staff are responsible for the safety of the patient on the mattress cover.



WARNING!

Risk of injury when positioning patient on the bed!

Before positioning the patient on the bed:

- ▶ Ensure that mattress is completely and correctly inflated.
- ▶ Ensure that mattress is correctly secured with safety straps.
- ▶ Use of the mattress without the safety straps could impair the mattresses ability to function correctly!



CAUTION!

Material damage due to dampness or contamination!

- ▶ Make sure mattress cover has been cleaned and is completely dry (see Cleaning/Disinfection).

Preparation

- ▶ Ensure that mattress is correctly secured with safety straps.
- ▶ Inflate mattress.
- ▶ Put a sheet loosely on the mattress if not prescribed otherwise by qualified personnel.

Position of a Patient on the Bed

- ▶ Put the patient on the mattress. Head of a lying patient points towards head end of the bed.
- Position of pelvic area is indicated by symbols on the inner sides of the Multicare X foot siderails, head board and foot board.



Fig. Symbol indicating centre of mattress support platform

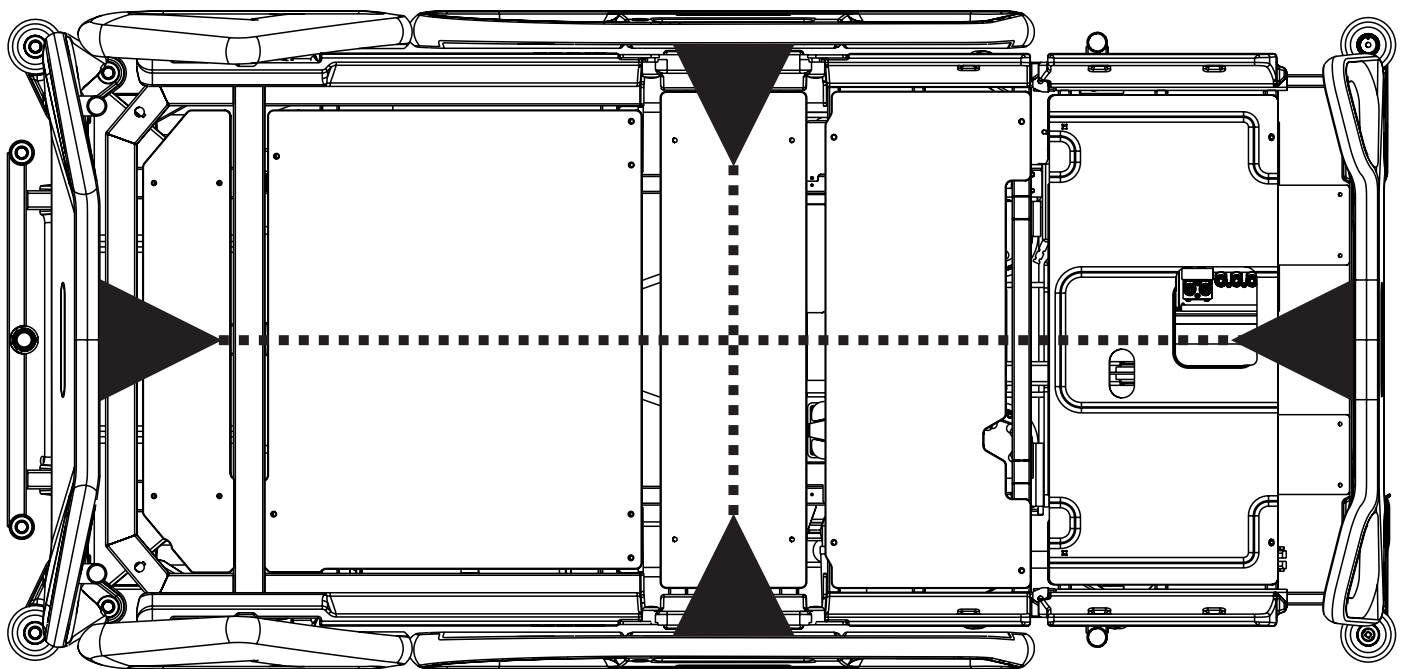

Fig. Centre of the Multicare X mattress support platform

Create the ideal patient position:

- ▶ If additional blankets or sheets are used, make sure that ease of movement is sufficient.
- ▶ Ensure that blankets, sheets, clothing etc. do not cause pressure injuries (e.g. due to creases, seams etc.).
- ▶ Do not place any additional sheets, blankets etc. between mattress and patient.

9.1 Manual CPR (during Transport or Power Loss)

OptiCare X is equipped with CPR valve on both sides next to the Manual Backrest Release.

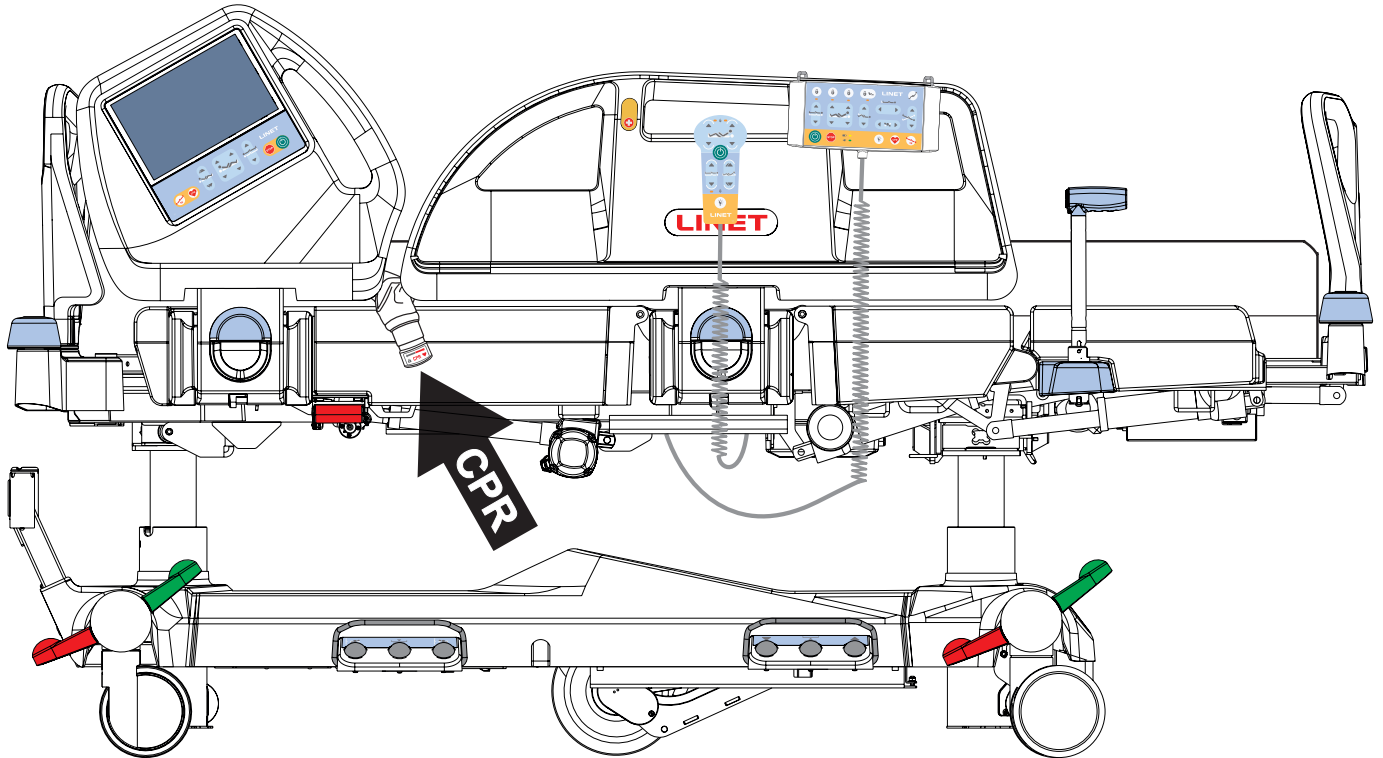

Fig. Position of the CPR valve on the OptiCare X integrated mattress placed on the Multicare X bed

To activate manual CPR:

- ▶ Open CPR valve on patient's left- or right-hand side by turning the end of CPR valve clockwise in accordance with the red arrow.
- ▶ The mattress will deflate.



Fig. CPR valve label

9.2 Automatic CPR (Multicare X with OptiCare X)

Cardiopulmonary Resuscitation Mode (CPR Mode) causes the mattress to deflate completely to facilitate resuscitation of patient. Typical deflation time for OptiCare X mattress is 15 seconds (max. 30 s). Timer indicator counts down 1 hour during CPR Mode.

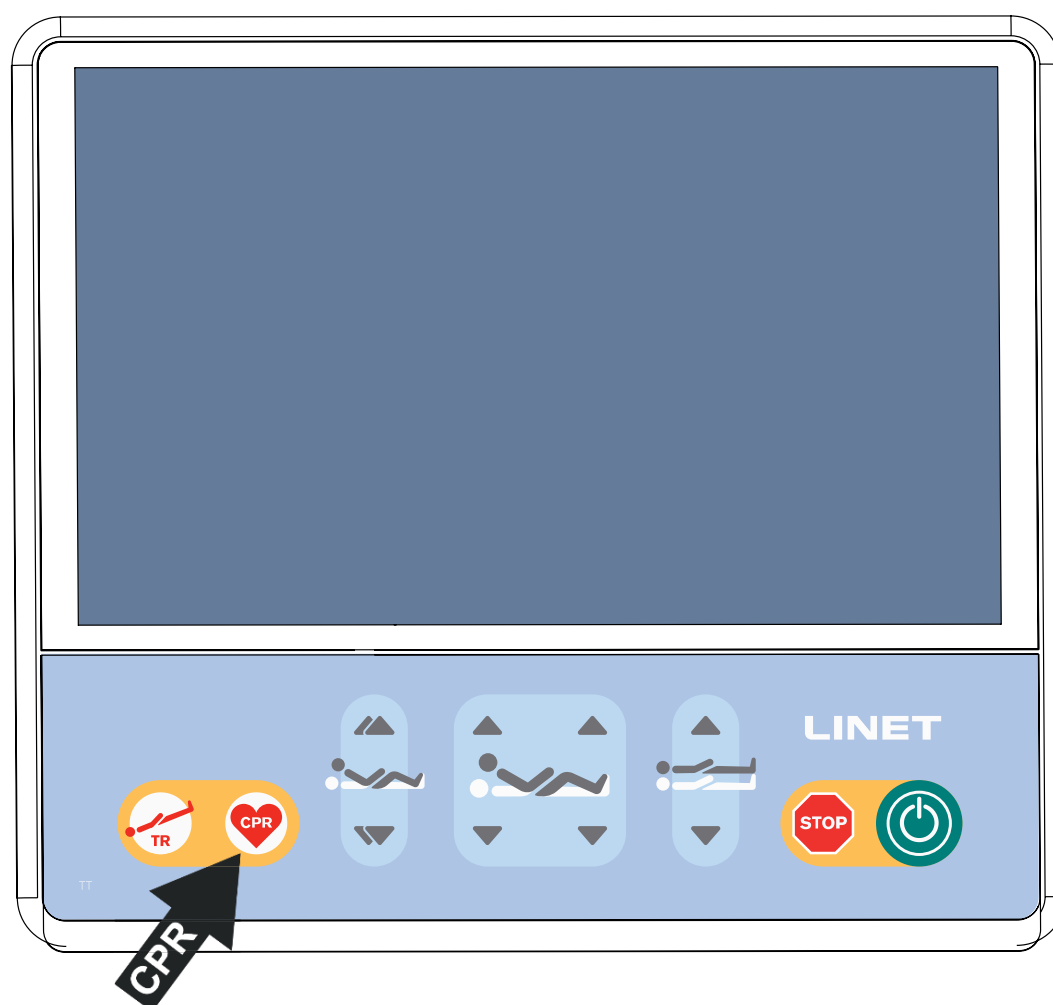

Fig. CPR button (Multiboard X)

To activate the CPR Mode on Multiboard X:

- ▶ Press and hold CPR button on the Multiboard X keyboard for at least 3 s.
The mattress deflates completely and mattress support platform will enter the CPR position.
The mattress platform will straighten up.

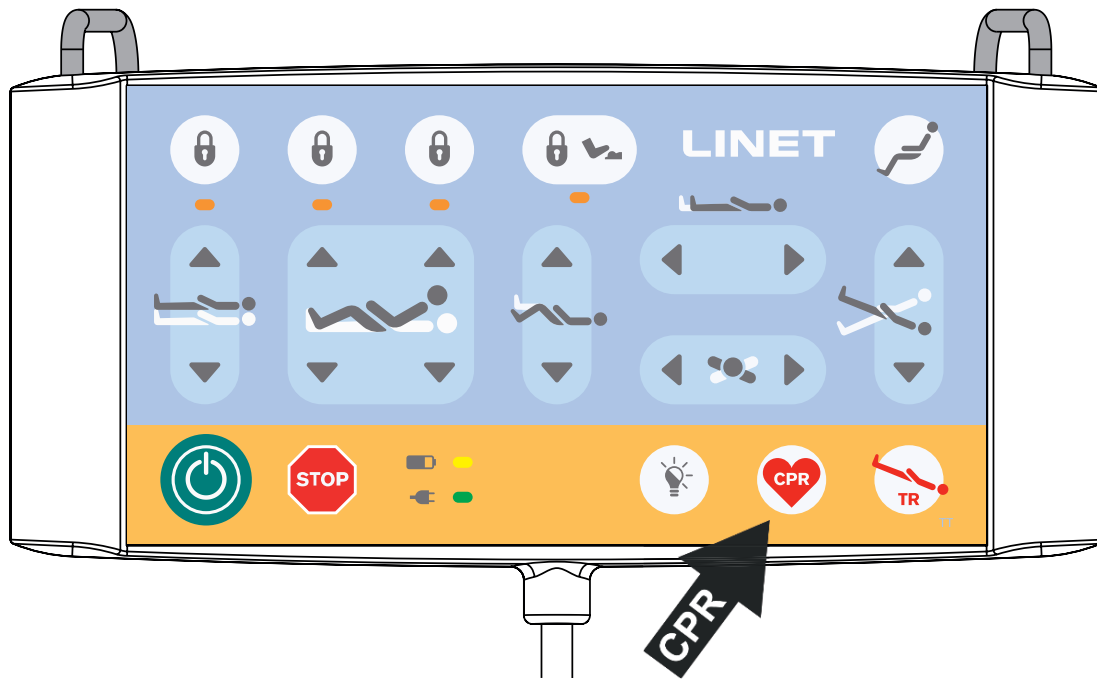

Fig. CPR button (Attendant Control Panel)

To activate the CPR Mode on Attendant Control Panel:

- ▶ Press and hold CPR button on the Attendant Control Panel for at least 3 s.
The mattress deflates completely and mattress support platform will enter the CPR position.
The mattress platform will straighten up.

9.3 Integrated Mattress Screen (Multicare X with OptiCare X)

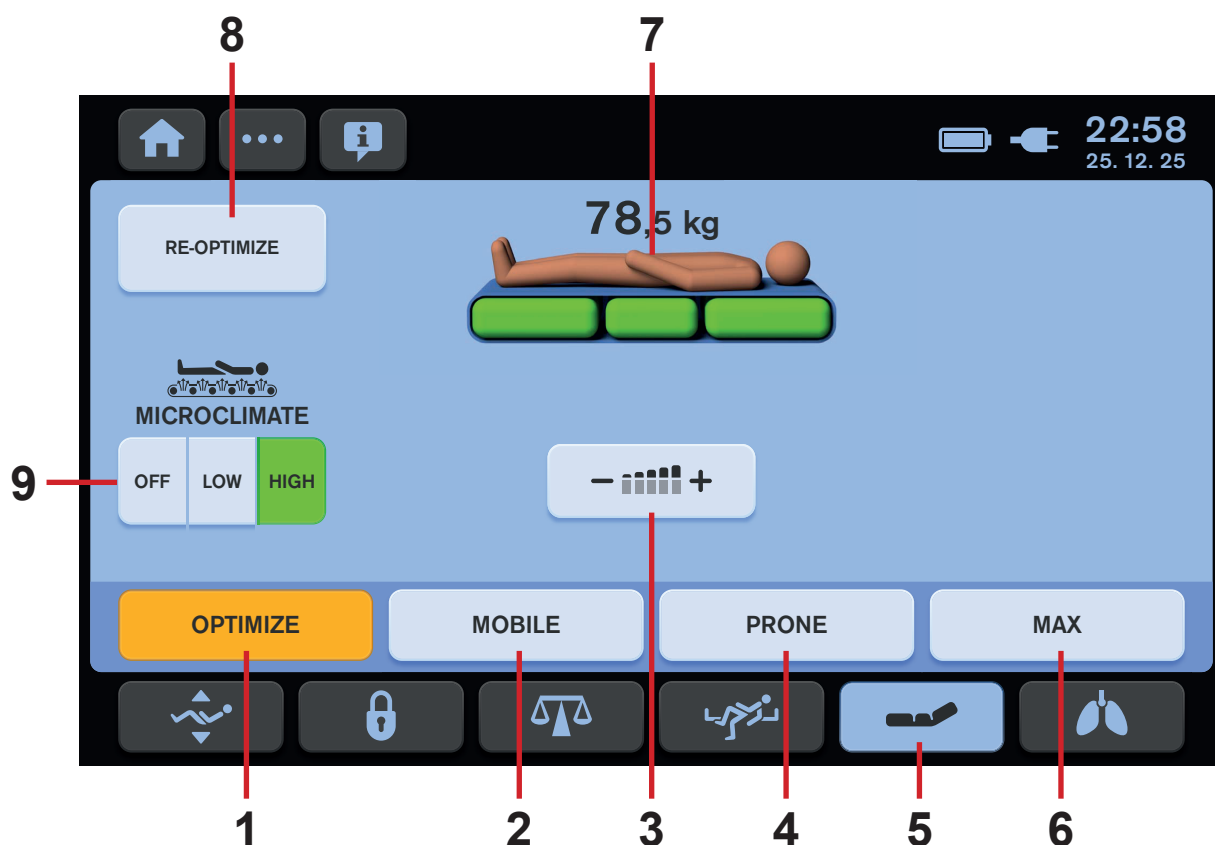

Fig. Integrated Mattress Screen - LCD touchscreen

1. OPTIMIZE Mode Icon (press to enter OPTIMIZE Mode)
2. MOBILE Mode Icon (press to enter MOBILE Mode)
3. Manual Pressure Settings Icon (press to enter Manual Pressure Settings)
4. PRONE Mode Icon (press to enter PRONE Mode)
5. Integrated Mattress Screen Icon (press to enter Integrated Mattress Screen)
6. MAX Mode Icon (press to enter MAX Mode)
7. Mattress Status Indicator (signalling mattress condition in relation to patient)
8. RE-OPTIMIZE Icon (press to start pressure optimisation process manually)
9. MICROCLIMATE Management Icons (OFF/LOW/HIGH)

Yellow colour on the Integrated Mattress Screen indicates activated function.
 Three green mattress parts are flashing during any mattress inflation process.

9.4 OptiCare X Mattress Controls (Multicare X with OptiCare X)

Control and information on status of the OptiCare X mattress is by the display and keyboard on the Multiboard X. Yellow colour on the LCD touchscreen indicates activated function.

9.4.1 MATTRESS DISCONNECTED

When OptiCare X compressor is installed on the bed but OptiCare X mattress is not connected to the compressor „MATTRESS DISCONNECTED“ screen appears. If the OptiCare X mattress has been deliberately removed from the mattress support platform in order to use an alternative mattress then you must log out the OptiCare X.

To connect OptiCare X mattress to the compressor:

- ▶ connect each air pipe to the compressor.

To log out OptiCare X mattress:

- ▶ press MATTRESS LOG OUT Icon.



Fig. Mattress Disconnected Screen

9.4.2 MATTRESS IDENTIFICATION

When OptiCare X mattress is connected to the compressor and its identification starts „MATTRESS IDENTIFICATION“ screen appears.

To achieve identification of connected mattress:

- ▶ wait until „MATTRESS IDENTIFICATION“ disappears.



Fig. Mattress Identification Screen

9.4.3 MATTRESS INFLATION

When OptiCare X mattress is identified it is not prepared for a patient because mattress is not inflated enough.

To achieve minimum inflation of the mattress:

- ▶ wait until „MATTRESS INFLATION“ disappears.



Fig. Mattress Inflation Screen

9.4.4 OPTIMIZE MODE

When OptiCare X has finished inflating, it will switch to Optimize Mode. This is the default mode. As long as the patient remains on the mattress automatic optimization of the mattress internal pressure continues. Optimization will occur if the patient's position changes sufficiently to trigger Optimization Detection, or if initiated by the Optimization automatic timer. The integrated MICROCLIMATE Management system will start working automatically when the patient gets into bed, and stops if the patient gets out (MICROCLIMATE OFF).

OptiCare X system in OPTIMIZE Mode detects when a patient has entered or left the bed. This automatically starts the optimization process on patient ingress and puts the mattress into Standby mode on patient egress. During Standby mode mattress areas A and B are inflated to a static pressure. There is a short stable pressure detection delay before reacting to change of status to prevent unnecessary mode changes because patient has changed position. If at any time nursing staff feel it necessary to re-optimize the patient then this can be initiated manually by touching the RE-OPTIMIZE Icon.

Optimization will stop working, the mattress will be inflated and air pressure level will be set according to the patient's weight if:

- ▶ The mattress support platform is tilted by 10 and more degrees (Anti-Trendelenburg Tilt).
- ▶ The mattress support platform is tilted by 10 and more degrees (Lateral Tilt).
- ▶ The mattress support platform is tilted by 5 and more degrees (Trendelenburg Tilt).
- ▶ Tilt reduction of the mattress support platform has value of 7 or less degrees (Anti-Trendelenburg Tilt).
- ▶ Tilt reduction of the mattress support platform has value of 7 or less degrees (Lateral Tilt).
- ▶ Tilt reduction of the mattress support platform has value of 3 or less degrees (Trendelenburg Tilt).
- ▶ Automatic Lateral Therapy (ALT) is activated.

To perform manual re-optimization:

- ▶ press RE-OPTIMIZE Icon.

To set intensity of MICROCLIMATE Management:

- ▶ press MICROCLIMATE OFF Icon to turn off the MICROCLIMATE Management.
- ▶ press MICROCLIMATE LOW Icon to lower intensity of the MICROCLIMATE Management.
- ▶ press MICROCLIMATE HIGH Icon to intensify the MICROCLIMATE Management.

NOTE: MICROCLIMATE Management will be automatically OFF if there is no patient on the mattress.

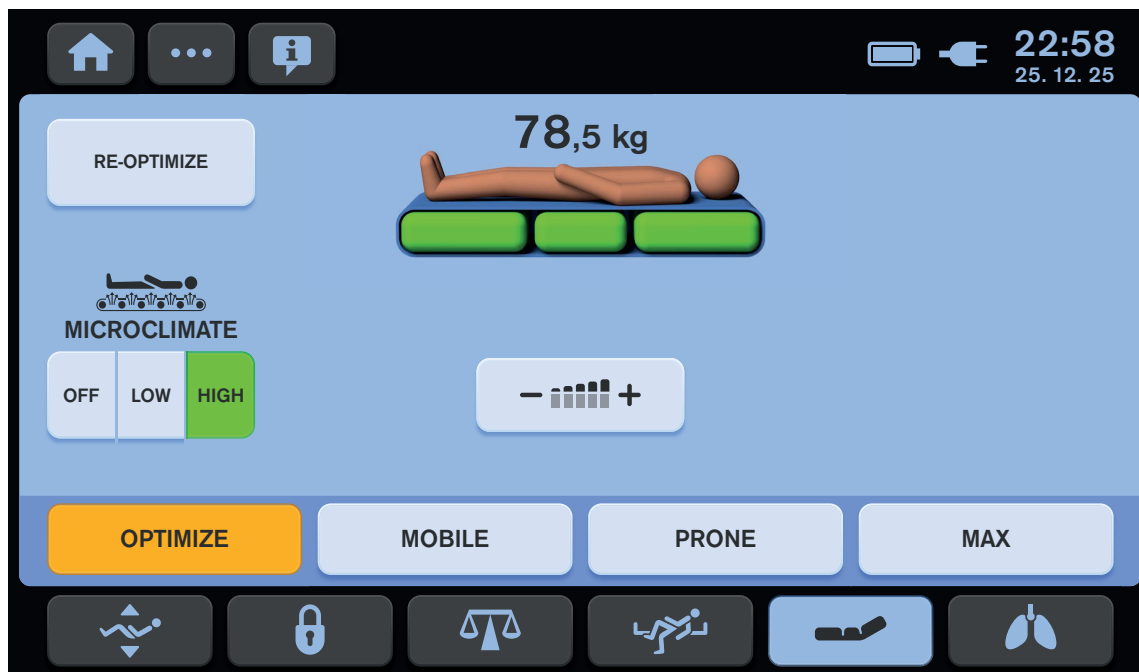

Fig. OPTIMIZE MODE

STANDBY SCREEN (IN OPTIMIZE MODE)

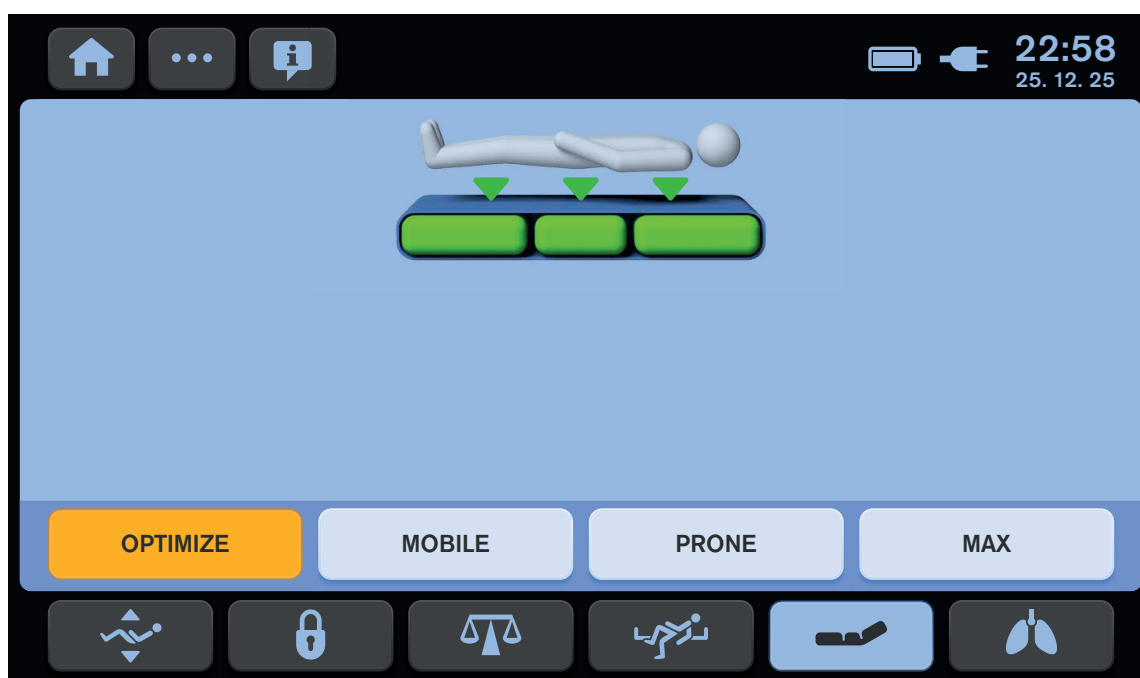

Fig. STANDBY SCREEN

To perform re-optimization when patient is on the mattress and STANDBY Screen appears in OPTIMIZE Mode:

- ▶ Switch OptiCare X to MOBILE Mode and shortly afterwards back to the OPTIMIZE Mode.
- ▶ If problem is still present and the STANDBY Screen remains displayed, position patient to the middle of the bed according to the marks on the bed.
- ▶ If problem is still present and the STANDBY Screen remains displayed, patient weight is lower than the minimum limit for patient (40 kg).

MANUAL PRESSURE SETTINGS (IN OPTIMIZE MODE)

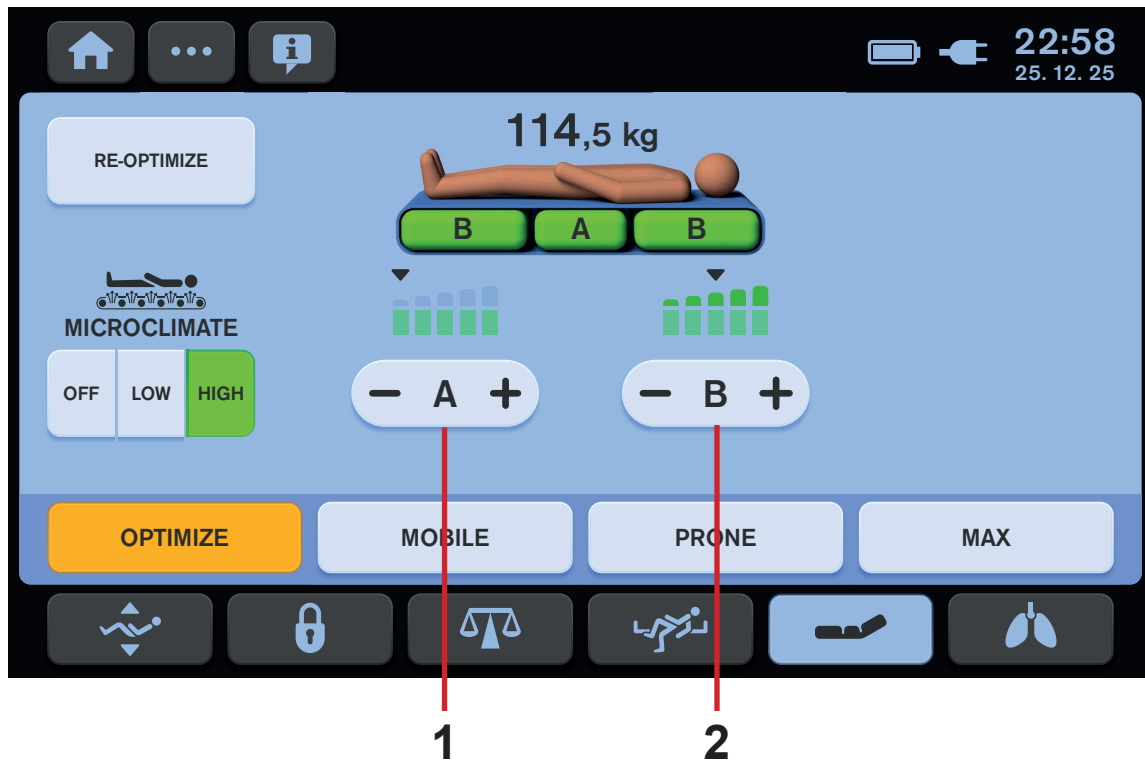

Fig. Manual Pressure Settings in OPTIMIZE Mode

To adjust air pressure in the mattress manually for seat section A:

- ▶ Press MINUS (-) on the **A** Section Icon (1) to decrease pressure level.
- ▶ Press PLUS (+) on the **A** Section Icon (1) to increase pressure level.

To adjust air pressure in the mattress manually for head and foot section B:

- ▶ Press MINUS (-) on the **B** Section Icon (2) to decrease pressure level.
- ▶ Press PLUS (+) on the **B** Section Icon (2) to increase pressure level.



Fig. Settings Screen 2 (Multiboard X)

To disable Manual Pressure Settings:

- ▶ Press Settings Screen Icon 1 (three dots).
- ▶ Select Settings Icon (gear).
- ▶ Press Round Icon 2.

Cross appears in the Round Icon 2.

To enable Manual Pressure Settings:

- ▶ Press Settings Screen Icon 1 (three dots).
- ▶ Select Settings Icon (gear).
- ▶ Press Round Icon 2.

Tick appears in the Round Icon 2.

9.4.5 MICROCLIMATE MANAGEMENT



WARNING!

Risk of incompatibility due to incorrect bed sheet!

- ▶ Use air-permeable bed sheet exclusively!

The MICROCLIMATE Management function starts to operate automatically when the SCU is turned on, mattress is connected and a patient is detected on the mattress. MCM function stops when patient leaves the bed and mattress. The integrated MCM function is achieved by providing air through two dedicated mattress parts running down each side of the torso section of the mattress. These manifolds direct the MCM air flow between the top surface of the mattress air cells and the inside surface of the top cover to encourage moisture vapour transmission. It is possible to set intensity of MICROCLIMATE Management during each mattress mode.

9.4.6 MOBILE MODE

MOBILE Mode is intended for providing a less immersive surface to improve comfort and facilitate such independent movement of the more mobile patients. The mattress air pressure can be adjusted based on the patient's needs. Black arrow in grey frame indicates recommended pressure level. It is possible to select only the nearest higher pressure level or the nearest lower pressure level. Each pressure level is suitable for different patient's weight.

Available pressure levels:

- ▶ 1: 40–54 kg
- ▶ 2: 54–90 kg
- ▶ 3: 90–135 kg
- ▶ 4: 135–180 kg
- ▶ 5: 180–250 kg

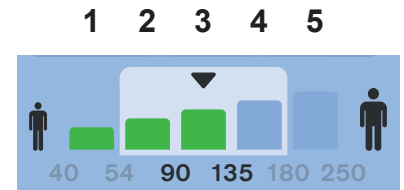

Fig. Five pressure levels

To adjust mattress air pressure:

- ▶ Press MINUS (-) Icon under the five pressure levels to decrease air pressure.
- ▶ Press PLUS (+) Icon under the five pressure levels to increase air pressure.

To adjust duration of the MOBILE Mode:

- ▶ Press PLUS (+) Icon next to the hourglass icon to add 1 hour to the MOBILE Mode operation.
- ▶ Press MINUS (-) Icon next to the hourglass icon to remove 1 hour of the MOBILE Mode operation.

OptiCare X system automatically returns to the OPTIMIZE Mode after the MOBILE Mode expiration.

To set unlimited duration of the MOBILE Mode:

- ▶ Press MINUS (-) Icon next to the hourglass icon when the last hour of the MOBILE Mode is passing. TIMER OFF is displayed above the hourglass icon when unlimited duration of the MOBILE Mode is adjusted.



Fig. MOBILE MODE

9.4.7 PRONE MODE



CAUTION!
Turn the patient on their back before leaving the Prone Mode!

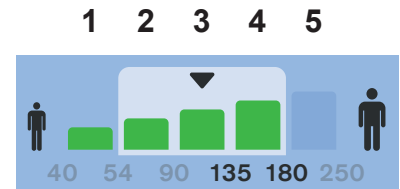

Fig. Five pressure levels

Prone Mode is intended for patients who need to lie prone. This mode does not provide optimization in order to prevent extubation of a patient and to prevent the breathing hoses from kinking. Prone Mode provides setting of the mattress internal pressure when patient lies prone. Stopwatch indicator shows how long patient lies prone (HOUR : MINUTE : SECOND).

To adjust mattress air pressure:

- ▶ Press MINUS (-) Icon under the five pressure levels to decrease air pressure.
- ▶ Press PLUS (+) Icon under the five pressure levels to increase air pressure.

Black arrow in grey frame indicates recommended pressure level. It is possible to select only the nearest higher pressure level or the nearest lower pressure level. Each pressure level is suitable for different patient's weight.

Available pressure levels:

- ▶ 1: 40–54 kg
- ▶ 2: 54–90 kg
- ▶ 3: 90–135 kg
- ▶ 4: 135–180 kg
- ▶ 5: 180–250 kg



Fig. PRONE MODE

Before leaving the PRONE Mode, a pop-up window will appear to remind you to check the patient's position on the mattress:

- ▶ Press TICK Icon to confirm that patient is lying on his/her back.
- ▶ Press CROSS Icon to return to the PRONE Mode.

If none of these options is selected during 30 seconds, the pop-up window will disappear and the PRONE Mode will continue.

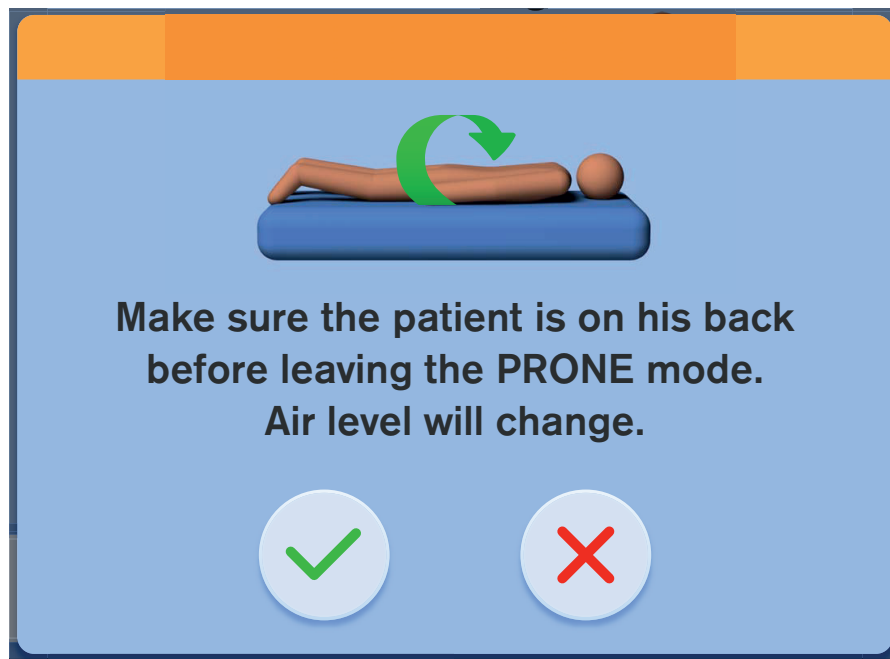

Fig. Check patient position after Prone Mode (warning pop-up window)

9.4.8 MAX MODE

MAX Mode is intended for sliding transfers, turning patients and certain medical procedures (e.g. physiotherapy). MAX Mode causes maximum mattress air pressure for 30 minutes. Countdown is displayed on the MAX Mode Screen above Icon with circular arrow in the upper left corner of the screen. OptiCare X system returns to previous mode after end of the MAX Mode.

To set Maximum Mattress Air Pressure for 30 minutes:

- ▶ press MAX Mode Icon.

To set Maximum Mattress Air Pressure for 30 minutes again:

- ▶ press Icon with circular arrow.

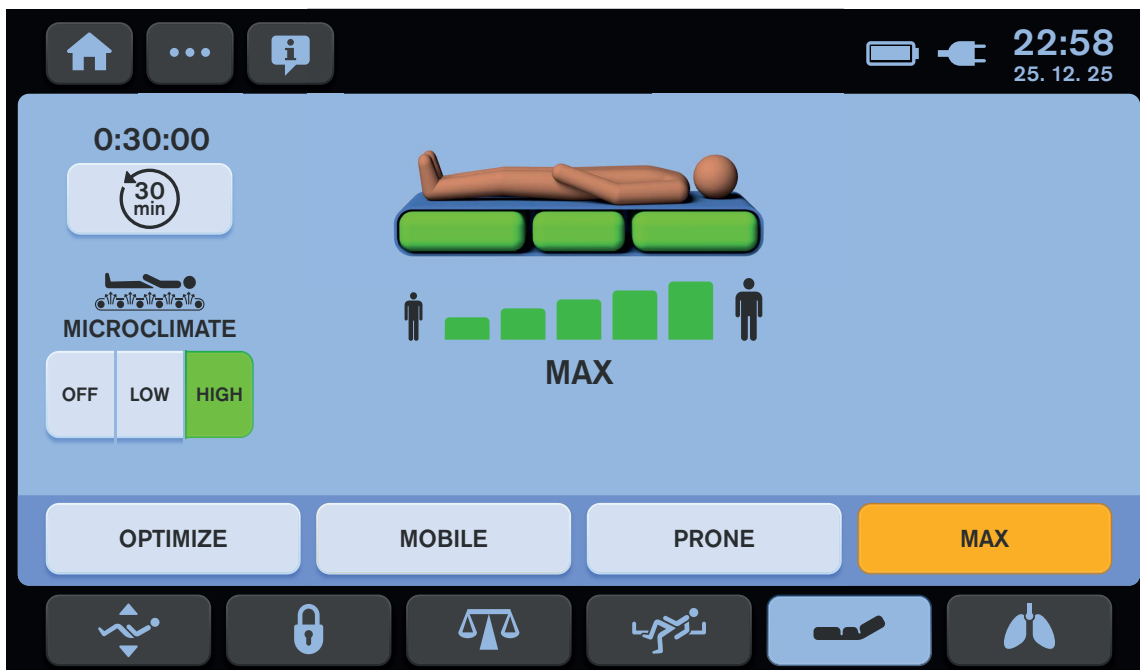

Fig. MAX MODE

9.4.9 CPR MODE (CPR ACTIVATED)

When CPR is activated, the mattress will deflate and chest compression can start immediately. CPR Mode period is limited to 1 hour and this period is counted down on the CPR Mode Screen. OptiCare X inflates automatically when this time is up. It is necessary to wait for the mattress inflation after switching from CPR Mode to OPTIMIZE Mode.

To deactivate CPR Mode:

- ▶ press CPR CANCEL Icon.
- The mattress will inflate again and return to the mode it was in before CPR started or to the mode it was in before MAX Mode if the mattress was in the MAX Mode before the CPR Mode.

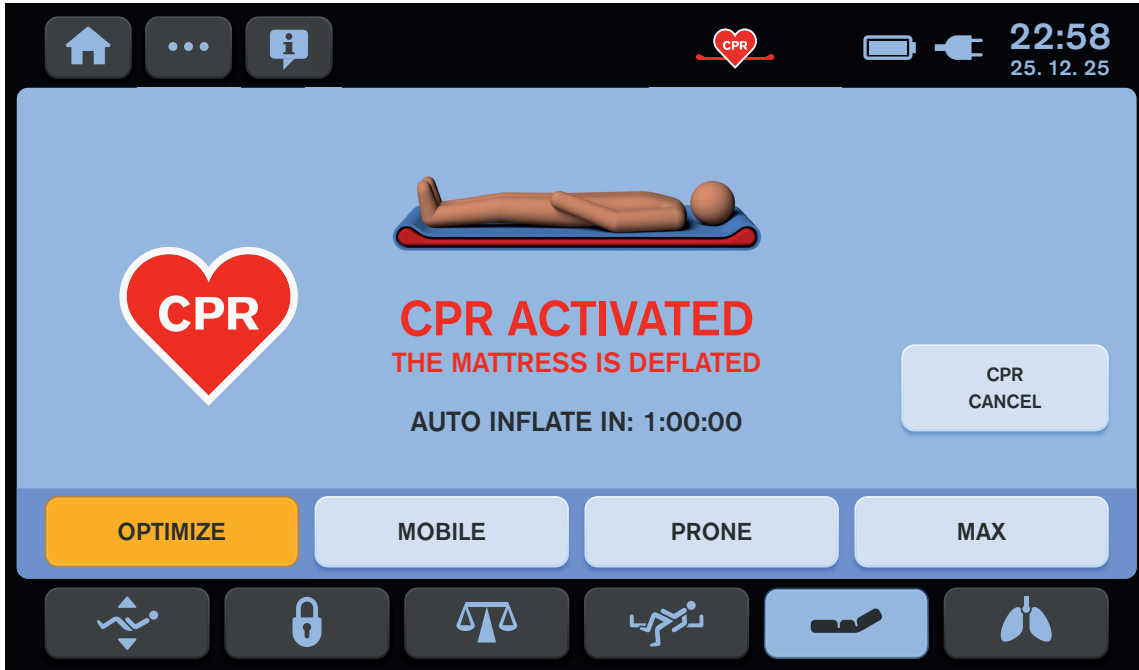

Fig. CPR MODE



Fig. Pop-up meaning mattress inflation after switching from CPR Mode to OPTIMIZE Mode

9.4.10 PUMP DISCONNECTED

When SCU is removed from the bed or communication between the bed and the SCU is lost this alert appears with „PUMP DISCONNECTED“ text.

To remove this alert:

- ▶ Install compressor on the bed!
- ▶ Log out the SCU on the Settings Screen 2. See „9.4.12 SCU LOG OUT“ on the page 45.
- ▶ If problem remains, contact the service department of the manufacturer!

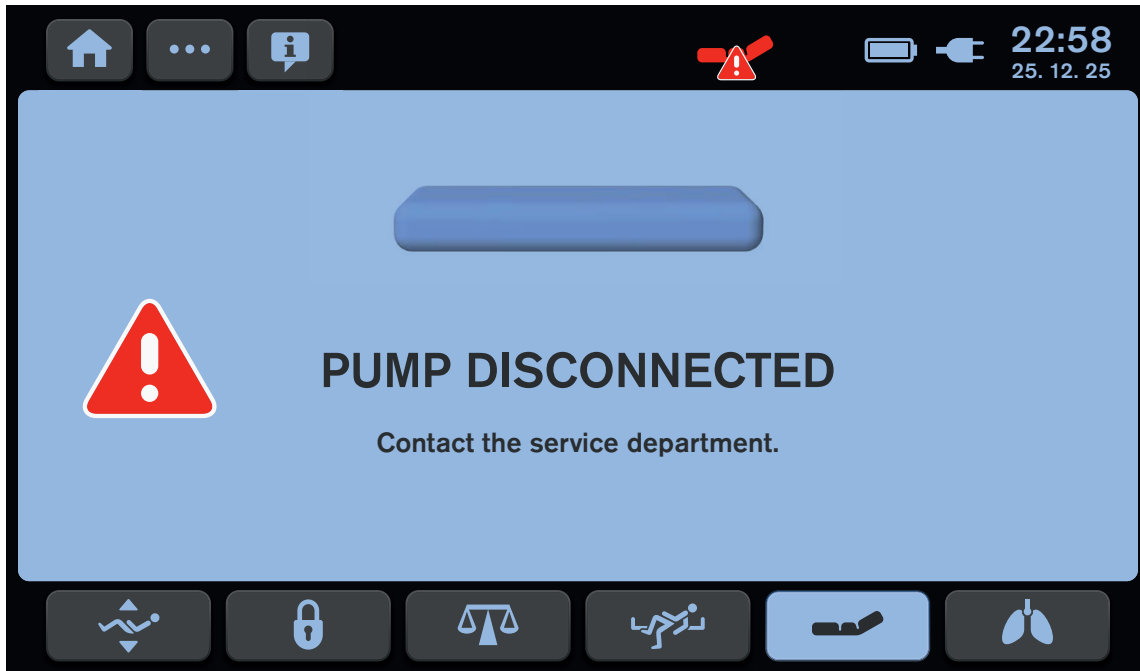

Fig. PUMP DISCONNECTED

9.4.11 AUTOMATIC PRESSURE ADJUSTMENT ERROR

Automatic mattress internal pressure adjustment in MOBILE Mode and PRONE Mode is not available when the Automatic Pressure Adjustment Error occurs. It is necessary to adjust the mattress internal pressure manually when this error occurs.

To eliminate this error:

- ▶ Check if the scales are stabilized and if the scales works properly.
- ▶ Check if the taring was performed without patient on the mattress.
- ▶ Contact the service department of the manufacturer if this error remains.

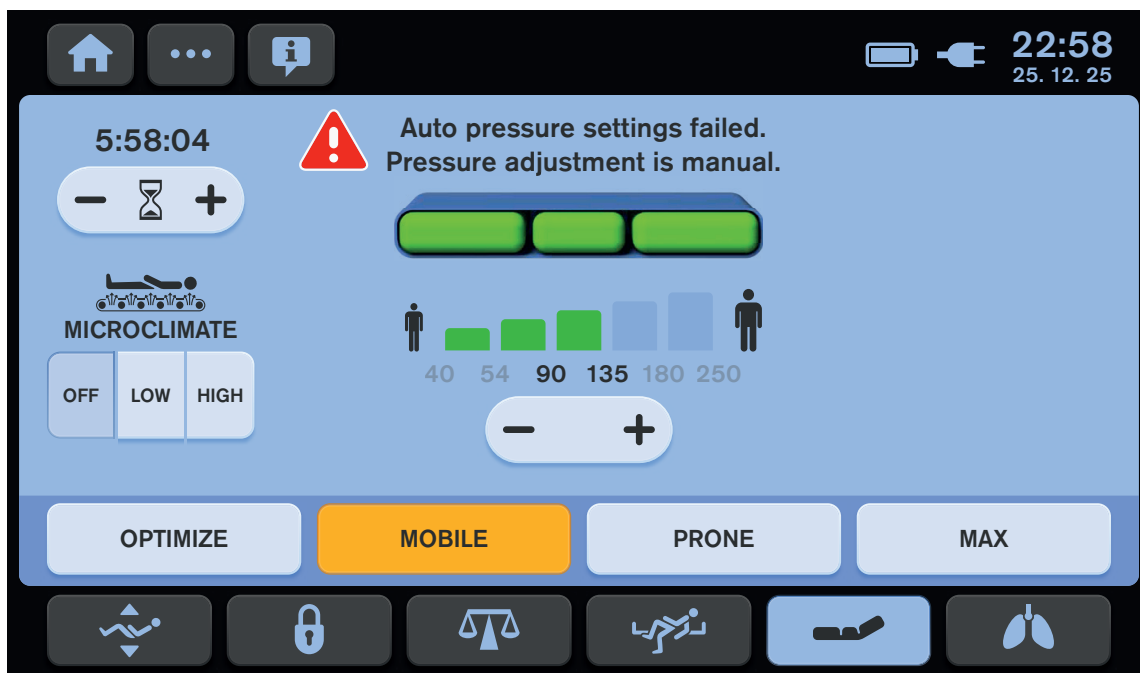

Fig. AUTOMATIC PRESSURE ADJUSTMENT ERROR

9.4.12 SCU LOG OUT

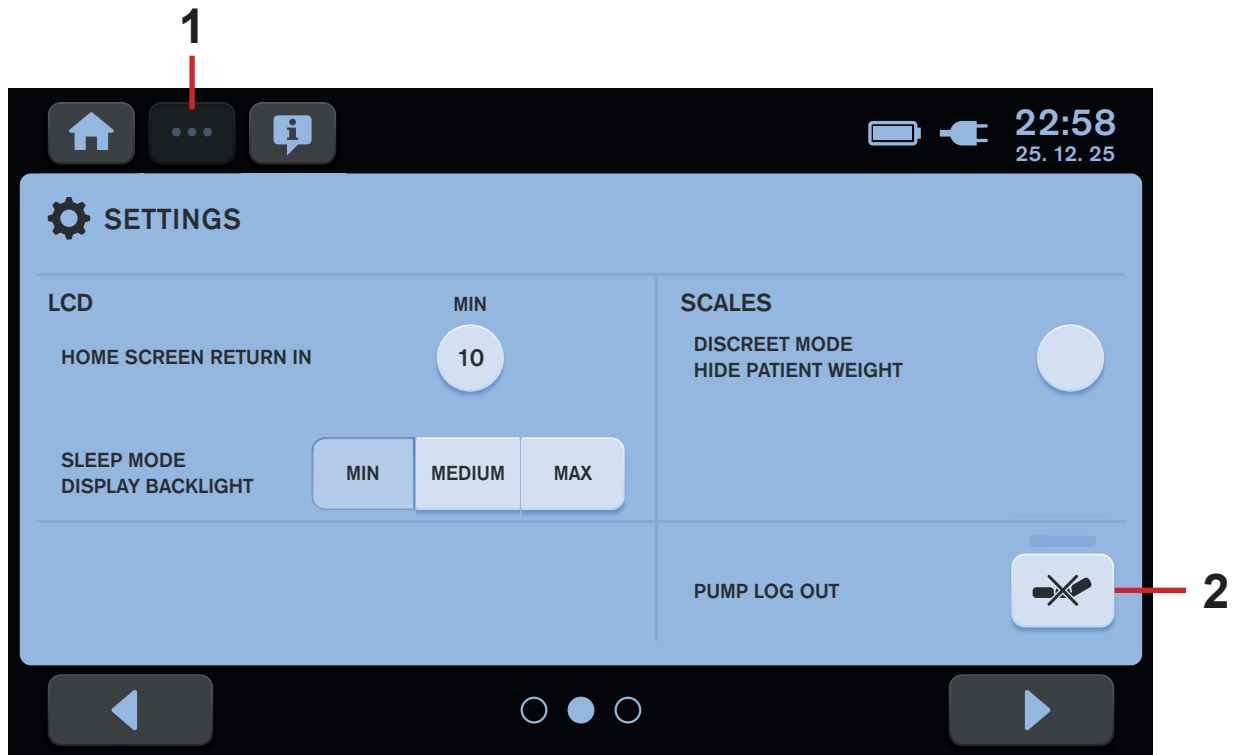

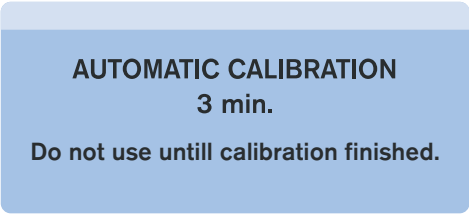

Fig. Settings Screen 2 (Multiboard X)

To log out OptiCare X SCU (compressor):

- ▶ Press Settings Screen Icon 1 (three dots).
- ▶ Select Settings Icon (gear).
- ▶ Press and hold Mattress Icon 2. The green stripe above the Mattress Icon 2 indicates development of the long press. Mattress Icon 2 is removed and the OptiCare X SCU is logged out.

9.4.13 STATUSES (Multiboard X - LCD touchscreen)

There are 2 types of pop-up windows related to the OptiCare X system according to the coloured stripe in the upper part of pop-up window. Red colour indicates warning with required action. Orange colour indicates caution with recommended action. Grey colour indicates only notification.

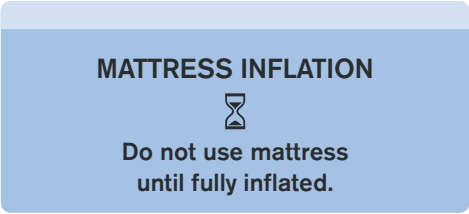
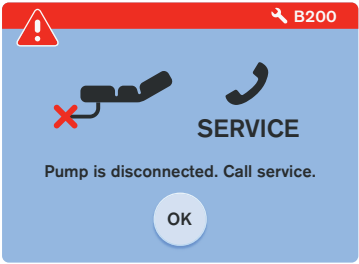
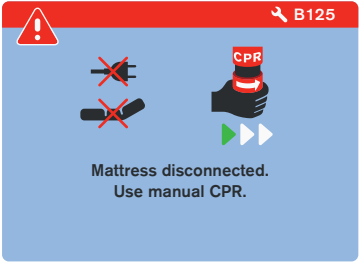
Status (Pop-up window)	Meaning	How to change the status
	Notification of the running automatic process that should not be disturbed.	Wait until the Automatic Calibration is finished.
	OPTIMIZE Mode of the OptiCare X integrated mattress cannot be activated because of longitudinal tilt or lateral tilt of the Multicare X bed.	Change lateral tilt adjustment or longitudinal tilt adjustment towards the bed horizontal position to enable activation of the OPTIMIZE Mode.
	Notification of the running inflation process of the OptiCare X mattress after switching from CPR Mode to OPTIMIZE Mode.	Wait until the mattress is inflated.
	OptiCare X System Control Unit (SCU) is disconnected.	Contact service department approved by manufacturer!
	Automatic CPR deflation is not available. OptiCare X System Control Unit could be disconnected.	Use manual CPR valve on a mattress side to deflate the OptiCare X mattress!

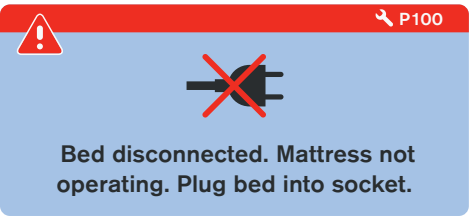
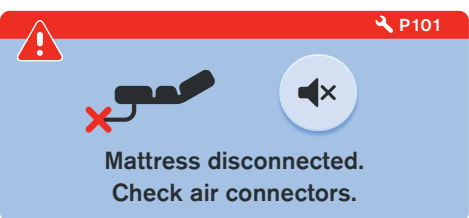
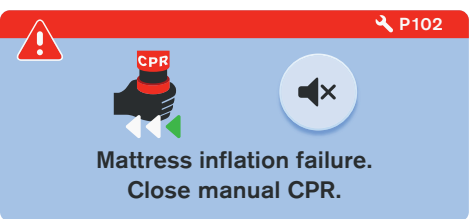
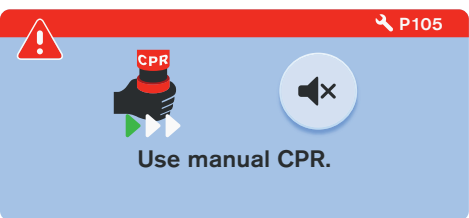
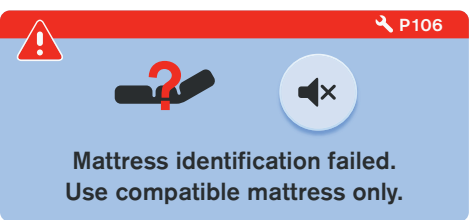
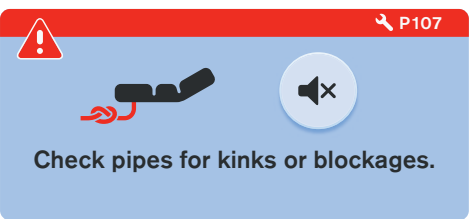
Status (Pop-up window)	Meaning	How to change the status
 <p>Bed disconnected. Mattress not operating. Plug bed into socket.</p>	<p>OptiCare X integrated mattress does not work because of the bed disconnected from the mains power.</p>	<p>Connect the bed to the mains power to enable functions of the OptiCare X integrated mattress!</p>
 <p>Mattress disconnected. Check air connectors.</p>	<p>At least one air hose is disconnected from the OptiCare X SCU.</p>	<p>Press MUTE Icon to mute acoustic alert sounding from SCU. Connect all the air hoses to the OptiCare X SCU.</p>
 <p>Mattress inflation failure. Close manual CPR.</p>	<p>Integrated Mattress inflation failed!</p>	<p>Press MUTE Icon to mute acoustic alert sounding from SCU. Close manual CPR valve or check air connections to SCU to enable mattress inflation! If problem is still present, transfer patient to another surface!</p>
 <p>Use manual CPR.</p>	<p>Integrated Mattress deflation failed! Automatic deflation is not available!</p>	<p>Press MUTE Icon to mute acoustic alert sounding from SCU. Open manual CPR valve to enable mattress deflation! If problem is still present, transfer patient to another surface!</p>
 <p>Mattress identification failed. Use compatible mattress only.</p>	<p>Mattress Identification failed! Connected mattress is not compatible with OptiCare X SCU!</p>	<p>Press MUTE Icon to mute acoustic alert sounding from SCU. Only connect the compatible mattress to the OptiCare X SCU! Check hoses in mattress near connection and re-connect the OptiCare X integrated mattress!</p>
 <p>Check pipes for kinks or blockages.</p>	<p>Mattress Identification failed due to a clogged or kinked air hose!</p>	<p>Press MUTE Icon to mute acoustic alert sounding from SCU. Ensure the air hoses are not kinked and remove found kinks and blockages! Check hoses in mattress near connection and re-connect the OptiCare X integrated mattress!</p>

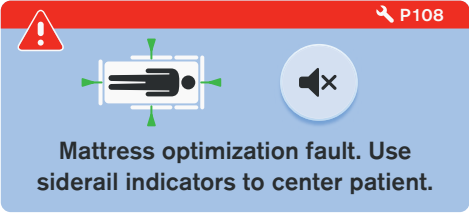
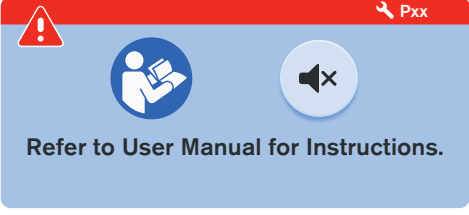
Status (Pop-up window)	Meaning	How to change the status
	<p>Optimization process has been stopped because patient is not properly placed on the OptiCare X integrated mattress.</p>	<p>Press MUTE Icon to mute acoustic alert sounding from SCU. Position the patient to the centre of the mattress support platform according to the indicators on the foot siderails, head board and foot board.</p>
	<p>Integrated Mattress Fault requiring an information from the instructions for use and intervention of a service technician! See "9.5 Fault Codes (OptiCare X integrated mattress)" on the page 49.</p>	<p>Press MUTE Icon to mute acoustic alert sounding from SCU. Follow the instructions for the corresponding fault code displayed in the upper right corner of the pop-up window (Pxx) and contact service department approved by manufacturer and report the identification fault code!</p>

FAULT RESET

To reset the displayed fault:

- ▶ Press MUTE Icon on the corresponding pop-up window. RESET Icon appears on the pop-up window instead of the MUTE Icon.
- ▶ Press RESET Icon.

The fault is reset.

If the fault cause was removed, the fault is eliminated.

If the fault cause was not removed, the fault will return with the corresponding pop-up window.



Fig. RESET Icon on the pop-up window P101

9.5 Fault Codes (OptiCare X integrated mattress)

Fault Code	Type of the Fault	Immediate Action of Operator	Corrective Action of Operator
P2	Major Inflate Fault (air leak)	Check both manual CPR valves for closing. OR Check air connections to SCU. If problem is still present, transfer patient to another surface.	If problem is still present, contact service department approved by manufacturer!
P3	Deflate Fault	Wait three minutes until fault self-clear. OR Check that air pipes between mattress and SCU are not kinked. If problem is still present, transfer patient to another surface.	If problem is still present, contact service department approved by manufacturer!
P4	Pressure Sensor Fault	Transfer patient to another surface.	Contact service department approved by manufacturer!
P5	Overpressure Fault	Transfer patient to another surface.	Contact service department approved by manufacturer!
P6	BOD Valve Fault	If the mattress is still supporting the patient, they should not move the patient to another surface if fault self-clears until 60 minutes. OR Transfer patient to another surface.	Contact service department approved by manufacturer!
P7	Blower Fault	No MCM function, assess the effect on patient.	Contact service department approved by manufacturer!
P8	Clogged Blower Filter	No MCM function, assess the effect on patient.	Contact service department approved by manufacturer!
P9	Communication Fault	Transfer patient to another surface.	Contact service department approved by manufacturer!
P12	Optimization Out of Range	Patient may be too heavy for the mattress or in a position that could prevent the BOD from closing. Check patient weight, patient's position and other medical device that is being used (e.g. traction, positioning aids etc.). OR Transfer patient to another surface.	Contact service department approved by manufacturer!
P14	Overcurrent of Solenoid	Transfer patient to another surface.	Contact service department approved by manufacturer!
P92	System Control Unit Overheating	Transfer patient to another surface.	Contact service department approved by manufacturer!
P94	Pressure Calibration Fault	Transfer patient to another surface.	Contact service department approved by manufacturer!
P98	Solenoid Fail	Transfer patient to another surface.	Contact service department approved by manufacturer!
P100	Find the corresponding graphic pop-up in the chapter „9.4.13 STATUSES (Multiboard X - LCD touchscreen)“ on the page 46 and follow the instructions related to it.		
P101			
P102			
P105			
P106			
P107			
P108			

10 Equipment

Product equipment depends on product configuration.

10.1 X-ray Pocket



CAUTION!

It is forbidden to wash the X-ray Pocket in the washing machine!

Mattress Cover ZONED could be equipped with X-ray Pocket.

The X-ray Pocket is accesible from the left side and from the right side of the OptiCare X integrated mattress.

The X-ray Pocket is connected to the mattress cover by zip so it can be removed from the mattress cover when it is completely unzipped.

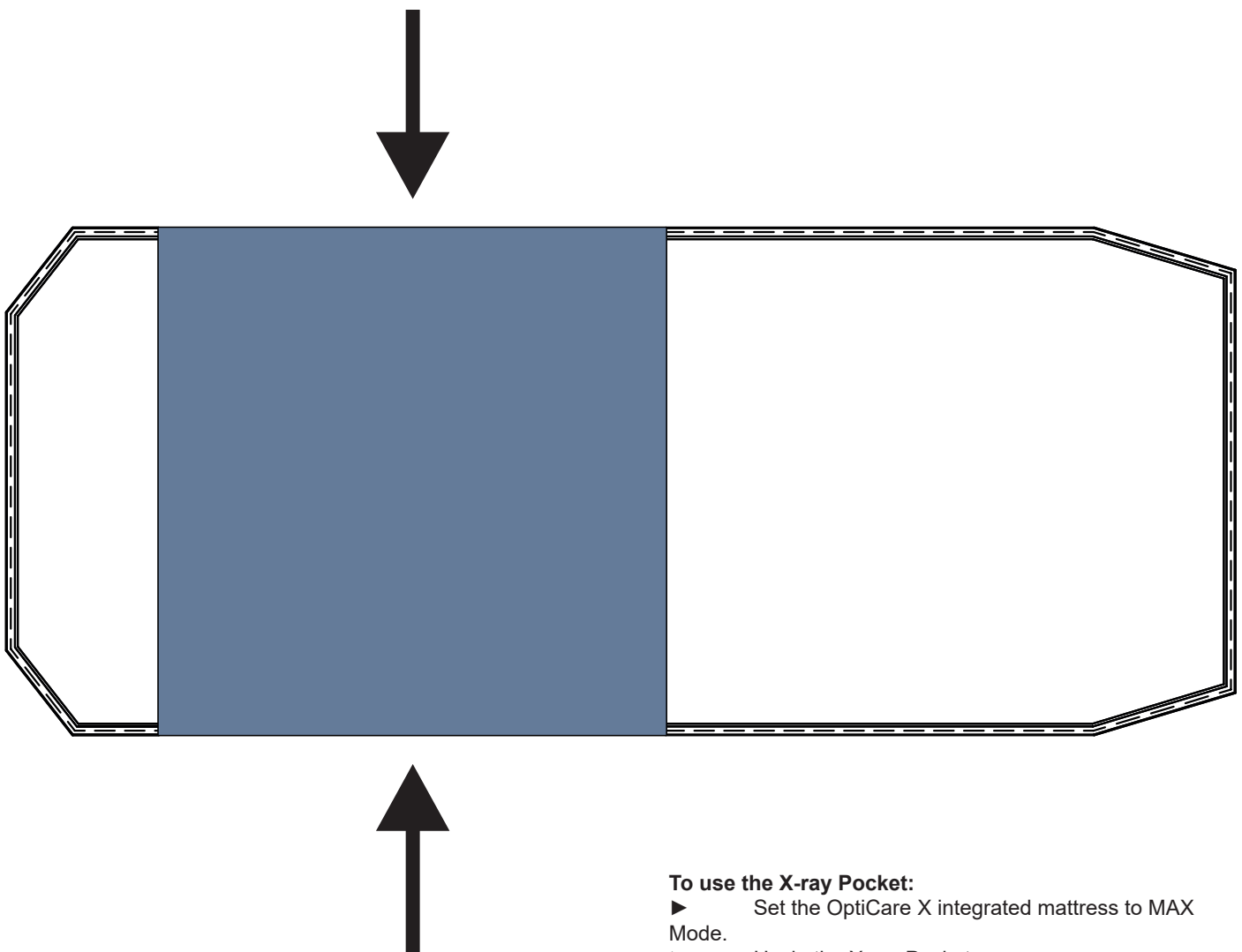

Fig. Access to the X-ray Pocket (mattress cover ZONED)

To use the X-ray Pocket:

- ▶ Set the OptiCare X integrated mattress to MAX Mode.
- ▶ Unzip the X-ray Pocket.
- ▶ Insert an X-ray cassette to the X-ray Pocket.
- ▶ Do the X-ray images.
- ▶ Remove the X-ray cassette from the X-ray Pocket.
- ▶ Zip the X-ray Pocket.
- ▶ Set the OptiCare X integrated mattress to the previous mode.

11 Cleaning/Disinfection (OptiCare X)



CAUTION!

Material damage due to incorrect cleaning/disinfection!

- ▶ Do not use pressure or steam cleaners.
- ▶ Follow the instructions and observe the dosages recommended by the manufacturer. Never exceed recommended concentrations stated in this document. Always rinse and dry before putting the mattress back into service, even if the chemical manufacturer states their cleaning agent need not to be rinsed.
- ▶ Ensure that disinfectants are selected and applied exclusively by qualified hygiene experts.

General Guidance – Standard Cover:

- ▶ Do not use any strong acids or alkalines, (optimum pH range 6 – 8. Do not exceed pH of 9). Some hard surface cleaners have pH values outside this range, these are not suitable for use on coated textiles.
- ▶ Only use detergents that are suitable for cleaning medical equipment and for use on coated textiles.
- ▶ Do not use abrasive powders, steel wool, or other material and cleaning agents that might damage the mattress. Do not scrub mattress surface.
- ▶ Never use any corrosive or caustic detergents.
- ▶ Never use detergents that deposit calcium carbonate.
- ▶ Never use detergents with solvents that might affect the structure and consistency of the plastics (benzene, toluene, acetone, phenol, etc.).
- ▶ Use only hospital-approved cleaners and observe local directives concerning infection control.
- ▶ Always rinse with water after cleaning and dry thoroughly before use.

Mattress parts to be cleaned	Recommended Cleaning Agents (General cleaning)
Top Cover High MVP (Moisture Vapor Permeable) Material	Standard hospital detergents, Alcohol or Quaternary Ammonium based disinfectants, Chlorine based disinfectants containing up to 1000ppm Chlorine, followed by rinsing with water and drying thoroughly before use.
	Decontamination: Blood spills/Clostridium difficile etc Chlorine based disinfectants containing up to 10,000 ppm Chlorine. Dwell time on surface at 10,000 ppm of 2 minutes, followed by rinsing with water and drying thoroughly before use. PU coated fabrics may feel dry to the touch, but still retain moisture. Wait until the surface is no longer cold to the touch before putting PU coated fabrics back into service.
Base Cover, Air Cells, Foam Base	As procedures above.

Due to the variety of laundry equipment, chemicals and conditions in use, customers should satisfy themselves through pre-testing. It is essential that articles be thoroughly rinsed and dried after all cleaning procedures and before storage or reuse. Wet or damp PU surfaces are more prone to mechanical damage than when dry.

As stated above, after application of a suitable cleaner, the surface must be rinsed with water and dried before use. (Even if the cleaner instructions say that this is not required). This prevents a build up of chemicals on the mattress surface which could be reactivated during use and affect biocompatibility and durability. The High MVP Coating may swell and change appearance during cleaning. This will recover after being thoroughly dried.

NOTE Continued use of high concentration, chlorine-based disinfectants may significantly reduce the performance and the working life of a coated material.

Type of Cleaning	Parts to be cleaned
Routine Cleaning and Disinfection	<ul style="list-style-type: none"> ■ Exposed mattress parts ■ Exposed SCU parts
Full Cleaning and Disinfection	<ul style="list-style-type: none"> ■ Exposed mattress parts ■ Exposed SCU parts ■ Internal parts of mattress ■ Internal parts of cover

11.1 Routine Cleaning and Disinfection

Cleaning the mattress:

- ▶ Check mattress cover top for any signs of damage.
Replace or repair and completely disinfect mattress cover top if damaged.
- ▶ Check inside of mattress cover top for signs of liquid ingress.
Replace or clean and completely disinfect mattress cover top if damp inside.
- ▶ Leave mattress cover on mattress.
- ▶ Clean with 60°C warm water and cleaning detergent.
- ▶ Rinse mattress with cold water.
- ▶ Let mattress dry or wipe dry.
- ▶ Wipe mattress with disinfectant.
- ▶ Rinse mattress with cold water.
- ▶ Let mattress dry or wipe dry.

Cleaning the SCU:

- ▶ Wipe SCU with disinfectant.
- ▶ Let SCU dry or wipe dry.

11.2 Full Cleaning and Disinfection

Cleaning the mattress:

- ▶ Deflate mattress and remove cover (see Removing the Mattress Cover).
- ▶ Check mattress cover top and base for any signs of damage.
Replace or repair and completely disinfect mattress cover top and base if damaged.
- ▶ Check mattress cover top and base for signs of liquid ingress.
Replace or clean and completely disinfect mattress cover top and base if damp inside.
- ▶ Clean all mattress cells and pipes with 60°C warm water and cleaning detergent.
- ▶ Rinse mattress with cold water.
- ▶ Let mattress dry air dry or wipe dry.
- ▶ Wipe mattress with disinfectant.
- ▶ Rinse mattress with cold water.
- ▶ Let mattress dry air dry or wipe dry.

Cleaning the mattress cover:

- ▶ Remove cover (see Removing the Mattress Cover).
- ▶ If machine washing mattress top/base covers, the temperature should be raised during the wash cycle, to 65°C/149°F, for 10 -15 minutes, or 71°C/160° F, for 3 - 10 minutes, using hospital approved detergents and rinsing agents.

NOTE Maximum wash temperature is 75°C/167°F.

- ▶ Dry cover in tumble dryer at low temperature.

Cleaning the air pipe:

- ▶ Wipe air pipe with cleaning agent or disinfectant.
- ▶ Let air pipe dry.

Cleaning the SCU:

- ▶ Remove filter.
- ▶ Wipe SCU and filter with disinfectant.
- ▶ Let SCU and filter dry.
- ▶ Reinsert filter.

11.3 Removing the Mattress Cover

- ▶ Carefully open zipper under side skirt of mattress cover on foot end of mattress.
 - ▶ Remove top part of mattress cover.
 - ▶ Undo corner toggles holding comforter cover and remove comforter cover.
- Inspect comforter cover and clean if necessary.
- ▶ Undo toggles holding top deck to foam base.
 - ▶ Undo plastic clip next to air pipe inlet on base cover holding foam base to cover.
 - ▶ Remove bottom part of mattress cover.

After cleaning the mattress cover:

- ▶ Reinstall mattress cover by reversing the process described above.
- ▶ Make sure all toggles are put back in their respective holes.

12 Troubleshooting (OptiCare X)



DANGER!

Risk of mortal injury due to electric shock!

- ▶ If a fault occurs, have the electric motor, power box or other electrical parts repaired by qualified personnel exclusively.
- ▶ Do not open the protective covers of the electric motor or the power box.



WARNING!

Risk of injury due to lack of support!

If the OptiCare X integrated mattress is empty so that the patient is lying directly on the foam base, and it is not possible to solve the problem by following the troubleshooting instructions:

- ▶ Move patient onto a suitable support surface as quickly as possible.

Problem	Nurse Action	Effect/Next Steps
<p>PUMP DISCONNECTED screen is shown on the Multiboard X touchscreen.</p>	<p>Disconnect the Multicare X Power Supply Cord from the mains, press STOP button and then connect the Power Supply Cord to the mains. Ensure the OptiCare X cable is screwed in the right side of SCU when looking under the calfrest from the bed right side.</p>	<p>Mattress Status Indicator should appear on the Mattress Screen.</p> <p>If neither happens, lift foot end of mattress, and visually check an Opticare X SCU is fitted (see picture of hose connections in the Instructions for Use). If it is, call service department.</p> <p>If essential the patient can be put back on the bed if alternative non-integrated mattress type is available.</p>
<p>Mattress display shows mattress fault pop up and red warning triangle in the Mattress section of display screen.</p>	<p>Lift foot end of mattress and visually check that the yellow, red and black OptiCare X air hoses are fitted correctly (see picture of hose connections in the Instructions for Use) and pushed fully down so that connector clicks into place.</p>	<p>Mattress display pop up and red warning triangle disappear. On Multiboard X picture of patient floating above the mattress appears.</p> <p>If neither happens, call service department.</p> <p>If essential the patient can be put back on the bed if alternative non-integrated mattress type is available.</p>
<p>Mattress display shows patient not in bed, but patient is in bed.</p>	<p>Check the scales are showing correct patient weight.</p>	<p>Scales are not showing correct patient weight.</p> <p>Mattress will remain inflated in Standby Mode and continue to support the patient, but no automatic pressure optimisation will happen.</p> <p>Press RE-OPTIMIZE Icon to request manual pressure optimisation. Mattress will perform Optimisation process and now show patient in bed.</p> <p>At first opportunity when patient is not in bed tare the scales (see Instructions for Use of the Multicare X bed).</p> <p>Scales show correct patient weight, but it is less than 40 kg.</p> <p>Press RE-OPTIMIZE Icon to request manual pressure optimisation. Mattress will perform Optimisation process and now show patient in bed. If it does not the patient is too light for functions of this mattress. Change OptiCare X for alternative active or passive mattress replacement system.</p>
<p>Mattress fails to automatically Optimize. Automatic Pressure Adjustment Error appears.</p>	<p>Adjust the mattress air pressure manually.</p> <p>Check if the scales are stabilized and if the scales works properly.</p> <p>Check if the taring was performed without patient on the mattress.</p>	<p>Patient level of movement (agitation/mobility) may be too frequent for OPTIMIZE Mode. In that case use MOBILE Mode.</p> <p>If problem continues, call service department who will advise next steps and if it is safe to continue to use the mattress.</p>

Problem	Nurse Action	Effect/Next Steps
<p>Mattress fails to inflate with no patient in bed.</p>	<p>Check both manual CPR valves are in closed position.</p> <p>Lift foot end of mattress and visually check that the yellow/red/black OptiCare X air hoses are fitted correctly (see picture of hose connections in the Instructions for Use) and pushed fully down so that connector clicks into place.</p>	<p>Select MAX Inflate Mode and the mattress should start to inflate. When mattress is inflated (pictures of the three green mattress parts on a mattress screen are not flashing), then put patient in bed and select your required operational mode.</p> <p>If mattress does not start to re-inflate it may be necessary to restart the SCU by disconnecting the Multicare X Power Supply Cord from the mains, pressing STOP button and then connecting the Power Supply Cord to the mains.</p> <p>If problem continues, call service department.</p> <p>If essential the patient can be put back on the bed if alternative non-integrated mattress type is available.</p>
<p>MCM not working (i.e. cannot hear noise of blower or patient skin is damp/signs of maceration).</p>	<p>Check MCM has been turned on and set to required level (LOW or HIGH).</p> <p>Lift foot end of mattress and visually check that the two blue OptiCare X air hoses are fitted correctly (see picture of hose connections in the Instructions for Use) and pushed fully down so that connector clicks into place.</p>	<p>Blower should be heard turning on or getting faster when MCM setting is increased.</p> <p>If blower can still not be heard patient can remain on the bed but service department should be called.</p> <p>If blower can be heard and the two blue hoses are connected correctly but patient is still showing signs of excess skin moisture, then other clinical interventions are required.</p>
<p>Electric CPR does not deflate mattress.</p>	<p>Push and Hold CPR button for at least 3 seconds.</p>	<p>Mattress should now deflate correctly.</p> <p>If this does not happen, use mattress manual CPR valves (see the Instructions for Use) and call service department.</p>
	<p>Use manual CPR. Pop-up window appears.</p>	<p>Mattress is not connected to the mains power or has CPR fault.</p> <p>Use manual CPR valve on either side of mattress head end (see the Instructions for Use).</p>
<p>Comfort controls not showing on the Mattress Screen in OPTIMIZE Mode.</p>	<p>Open second settings screen and select OPTIMIZE MODE - COMFORT ADJUSTMENT controls ON (see the Instructions for Use).</p>	<p>COMFORT ADJUSTMENT controls should now appear when mattress is in OPTIMIZE Mode.</p>
<p>Fault codes warning pop-up window with code below 100 is displayed.</p>	<p>Take note of fault code number and call service department.</p>	<p>Call service department who will advise next steps and if it is safe to continue to use the mattress.</p>
<p>Graphic pop-up window with code equal and above 100 is displayed.</p>	<p>Check for problem as shown by the window (see the Instructions for Use).</p>	<p>If nurse clears problem, continue to use the mattress.</p> <p>If nurse cannot clear problem, call service department who will advise next steps and if it is safe to continue to use the mattress.</p>

Problem	Nurse Action	Effect/Next Steps
<p>Patient feels that they are / nurse thinks that the patient is sitting directly on the bed frame and not being supported by the mattress.</p>	<p>Use COMFORT ADJUSTMENT controls to increase air pressure in the mattress areas A & B (see the Instructions for Use).</p>	<p>Patient should now look/feel that they are not in contact with the mattress support platform.</p> <p>If in doubt, this can be checked by moving or asking the patient to move slightly from side to side. They should move fairly easily.</p> <p>If this is not the case and there are no mattress alarms, consider repositioning the patient or using an alternative mattress that can support heavier weight patients.</p>
<p>Patient's rest disturbed by mattress automatic re-optimising.</p>	<p>Use MOBILE Mode.</p>	<p>Ensure the patient feels more comfortably.</p>

13 Maintenance (OptiCare X)



WARNING!

Risk of injury when working on the mattress system!

- ▶ Ensure that the mattress system is disconnected from the mains power prior to installation, putting into service, maintenance and deinstallation.



WARNING!

Risk of injury due to defective mattress system!

- ▶ Have a defective mattress system repaired immediately.
- ▶ If the defect cannot be repaired, do not use the mattress system.



CAUTION!

Material damage due to incorrect maintenance!

- ▶ Ensure that maintenance is performed exclusively by manufacturer's customer service or by authorised service personnel certified by the manufacturer.
- ▶ If the defect cannot be repaired, do not use the mattress system.

13.1 Regular maintenance

- ▶ Perform regularly visual check of the product (with delivery note if necessary).
- ▶ Ask service department of the manufacturer for addition of the original spare parts if some product parts are missing.
- ▶ Ask service department of the manufacturer for replacement of any damaged product parts by the original spare parts.
- ▶ Check inside and outside of mattress and outside of SCU for mechanical damage and signs of severe wear and tear.
- ▶ Check if mattress and SCU are working properly.
- ▶ Check external air filter in side of SCU for dust and dirt. If dust or dirt is visible, replace filter.

13.2 Spare Parts

The serial label is located on the SCU and on the mattress. The serial labels contain information for claims and ordering replacement parts.

Information about spare parts is available from:

- Manufacturer's customer service
- Sales department

13.3 Safety Technical Checks



WARNING!

Risk of injury due to incorrect safety technical checks!

- ▶ Ensure that safety technical checks are performed exclusively by manufacturer's customer service or by authorised service personnel certified by the manufacturer.
- ▶ Ensure that the safety technical checks are recorded in the service and maintenance log.

Safety technical check of the mattress system must be performed at least once every 12 months.

The procedure for performing the safety technical check is stipulated in EN 62353:2014.

NOTE On request, the manufacturer will provide service documentation (e.g. circuit diagrams, component part lists, descriptions, calibration instructions etc.) for service personnel for the repair of ME equipment designated by the manufacturer as repairable by service personnel.

14 Disposal (OptiCare X)

14.1 Environment Protection

The company LINET® is aware of the importance of environmental protection for future generations. Within this company the environmental management system is applied in accordance with the internationally agreed standard ISO 14001. The compliance with this standard is annually tested by the external audit executed by an authorised company. Based on the Directive No. 2002/96/EC (Directive **WEEE** - Waste, Electric and Electronic Equipments) the company LINET, s. r. o. is registered in the List of Electric and Electronic Equipment Producers (**Seznam výrobců elektrozařízení**) on the Ministry of the Environment of the Czech Republic (Ministerstvo životního prostředí).

Materials used in this product are not environmentally hazardous. LINET® products meet valid requirements of national and European legislation in the areas of **RoHS** and **REACH**, so they do not contain any prohibited substances in excess quantities. None of the wooden parts is made of tropical wood (such as mahogany, rosewood, ebony, teak etc.) or made of timber from the Amazon region or from similar rainforests. Product noise (sound pressure level) meets requirements of the regulations for the protection of public health against undesirable effects of noise and vibration in protected interior spaces of buildings (according to standard IEC 60601-2-52). Used packaging materials are in accordance with requirements of the Packaging Act (**Zákon o obalech**). For disposal of packaging materials after installation of products contact your sales representative or manufacturer's customer service about the possibility of a free take-back of packaging through an authorized company (more details on www.linnet.cz).

14.2 Disposal

The main objective of the obligations arising from the European Directive No. 2012/19/EU on Waste, Electric and Electronic Equipments (nationally regulated in Act No. 185/2001 Coll. as amended. On Waste and in Decree of the Ministry of the Environment No. 352/2005 Coll. as amended), is to increase the re-use, material recovery and recovery of electric and electronic equipment at the required level, thereby avoiding the production of waste and thereby avoiding the possible harmful effects of hazardous substances contained in electric and electronic equipment on human health and the environment. LINET® electric and electronic equipments that have a built-in battery or accumulator are designed so that the used batteries or accumulators can be safely removed by LINET® qualified service technicians. There is an information about its type on the built-in battery or accumulator.

14.2.1 Within Europe

To dispose of the electric and electronic equipment:

- ▶ The electric and electronic equipment must not be disposed of as household waste.
- ▶ Dispose of this equipment at designated collection points or take-back points.

To dispose of the other equipment:

- ▶ The equipment must not be disposed of as household waste.
- ▶ Dispose of this equipment at designated collection points or take-back points.

LINET® participates in a collective system with take-back company REMA System (see www.remasystem.cz/sberna-mista/). By bringing electric and electronic equipment to a take-back point, you participate in recycling and you save primary raw material resources while protecting your environment from effects of unprofessional disposal.

14.2.2 Outside Europe

- ▶ Dispose of the product or its components in accordance with local laws and regulations!
- ▶ Hire an approved waste disposal company for disposal!

15 Warranty (OptiCare X)

LINET® will only be held responsible for the safety and reliability of products that are regularly serviced, maintained and used in accordance with the safety guidelines.

Should a serious defect arise that cannot be repaired during maintenance:

- ▶ Do not continue to use the bed.

Warranty duration is subject to individual purchasing agreements with a minimum length of 24 months.

The warranty covers all material and manufacturing-related failures and errors. Failures and errors caused by incorrect use and external effects are not covered. Justified complaints will be fixed free of charge during the warranty period. Proof of purchase, with the date of purchase, is required for all warranty service.

16 Standards and Regulations (OptiCare X)

Applied norms are stated on Declaration of Conformity.

The manufacturer adheres to a certified quality management system in compliance with the following standards:

- ISO 9001
- ISO 14001
- ISO 13485
- MDSAP (Medical Device Single Audit Program)