

Instructions for Use and Technical Description

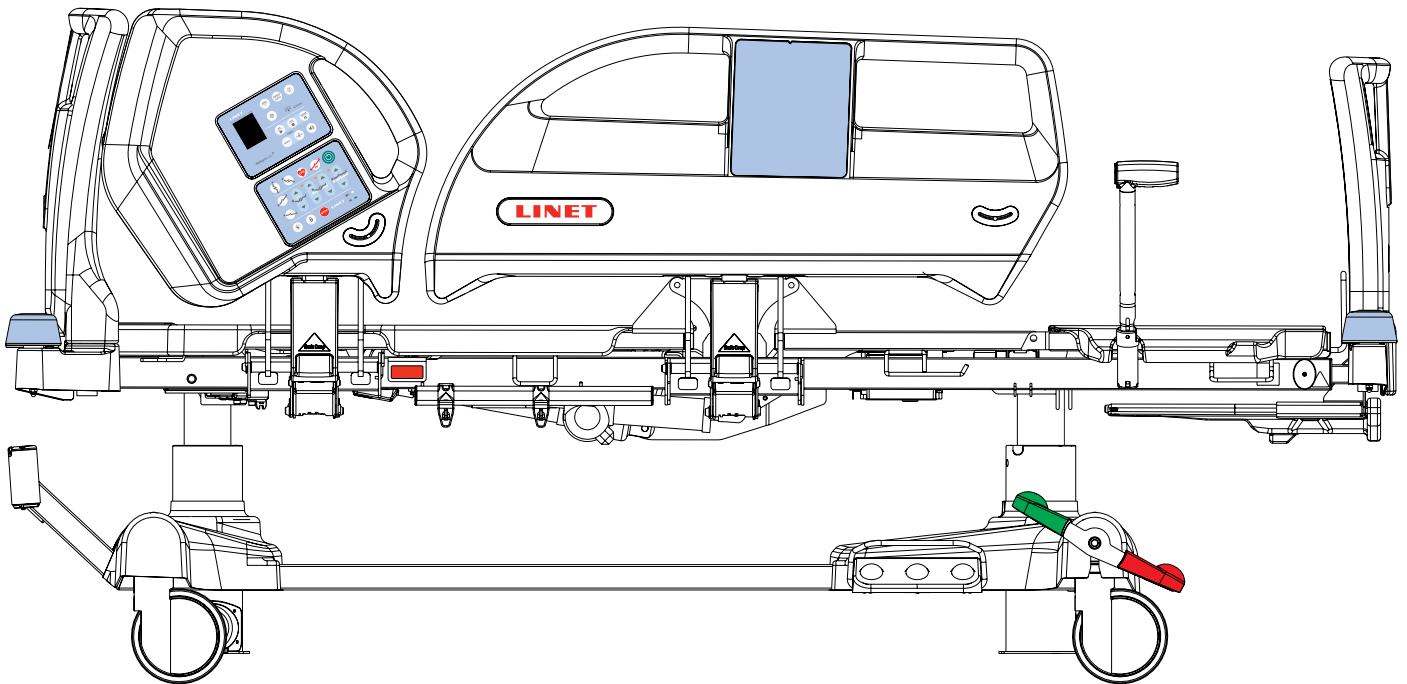

ELEGANZA 4

Positionable Bed for Intensive Care

version with scales and without scales

CE
0123

CE

**UK
CA**

D9U001GE4-0101

Version: 13

Publication Date: 2023-03

Manufacturer:

L I N E T spol. s r.o.
Želevčice 5
274 01 Slaný

Tel.: +420 312 576 111
Fax: +420 312 522 668

E-mail: info@linet.cz
<http://www.linet.com>
Service department: service@linetgroup.com

Authorized Representative in Great Britain:

LINET UK Ltd
11 Brunel Way
Segensworth East
Fareham
Hampshire
PO15 5TX
United Kingdom

Authorized Representative in Switzerland:

Bigla Care AG
Bernstrasse 3
CH-3421 Lyssach
Switzerland

Authorized Representative in Malaysia:

Emergo Malaysia Sdn. Bhd.
Level 16, 1 Sentral, Jalan Stesen Sentral 5
KL Sentral
50470 Kuala Lumpur
Malaysia

Authorized Representative in Peru:

Drogería Emergo Peru S.R.L.
Calle Las Orquídeas Nro. 585, Int. 1301
San Isidro, Lima
Director Técnico Renato Delgado Rivera
RUC: 205 52 75 65 35
Peru

Authorized Representative in Philippines:

Biomedica Healthcare Inc.
Unit 2103 City land 10, Tower 1
Ayala Corner, Dela Costa Street
Makati City, Metro Manila
Philippines

Eleganza 4

Positionable bed for intensive care

Author: L I N E T, s.r.o.

Related links: www.linnet.com

D9U001GE4-0101

Version: 13

Publication Date: 2023-03

Copyright © L I N E T, s.r.o., 2023

Translation © L I N E T, 2023

All rights reserved.

All trademarks and brands are the property of the appropriate owners. The manufacturer reserves the right to changes in the contents of this instructions for use that relate to the product's technical regulations. It is for this reason that the contents of this instructions for use may indicate differences from the current manufacture of the product. Reproduction, also excerpts, only with prior permission of the publisher. Subject to changes due to technical developments. All technical data are rated data and are subject to construction and manufacturing tolerances.

Table of Contents

1 Symbols and Definitions	6	11.5.1 Backrest	53
1.1 Warning Notices	6	11.5.2 Thighrest	54
1.1.1 Types of Warning Notices	6	11.5.3 Mechanical Calfrest Adjustment	56
1.1.2 Structure of Warning Notices	6	11.5.4 Bed Height	57
1.2 Instructions	6	11.5.5 Autocontour	59
1.3 Lists	6	11.5.6 Examination Position	60
1.4 Symbols on the Package	7	11.5.7 Emergency Trendelenburg Position	62
1.5 Symbols and Labels on the Bed	8	11.5.8 Anti-Trendelenburg Tilt and Trendelenburg Tilt	63
1.6 Acoustic signalisation	13	11.5.9 CPR Position	65
1.7 Visual signalisation	14	11.5.10 Mechanical Bed Extension	66
1.7.1 NIGHT LIGHT	14	11.5.11 Cardiac Chair Position	69
1.7.2 Mains Power LED (Nurse Control Panel, Attendant Control Panel)	14	11.5.12 Mobilisation Position	70
1.7.3 Accumulator indicator (Nurse Control Panel, Attendant Control Panel)	14	11.5.13 Ergoframe	70
1.7.4 Lock LED (Nurse Control Panel, Attendant Control Panel)	15	12 Scales Control (only version with scales)	71
1.8 Definitions	15	12.1 Preparation	71
1.9 Abbreviations	16	12.2 Taring	71
2 Safety Instructions	17	12.3 Displaying	71
3 Intended use	20	12.4 Hold Mode	72
3.1 User population	20	12.5 Bed Overload	72
3.2 Contraindications	20	12.6 Bed Underload	72
3.3 Operator	20	12.7 Weighing in tilt	72
4 Product Description	21	12.8 Zeroing Scales	72
5 Technical Specification	22	13 Bed Exit Monitoring (only version with scales)	73
5.1 Identification of Applied Parts (Type B)	22	13.1 Preparation	73
5.2 Scales	22	13.2 Activation of Bed Exit Monitoring	73
5.3 Mechanical Specifications (Eleganza 4)	22	13.3 Monitored Zone	73
5.4 Environment Conditions	23	13.4 BED EXIT ALARM	74
5.5 Electrical Specifications (Eleganza 4)	23	13.4.1 Alarm Volume	74
5.6 Electromagnetic Compatibility	24	13.5 PAUSE	74
5.6.1 Manufacturer instructions - electromagnetic emissions	24	13.6 Deactivation of Bed Exit Monitoring	74
5.6.2 Manufacturer instructions - electromagnetic susceptibility	25	14 Equipment	75
6 Use and Storage Conditions	26	14.1 Accessory Rail with plastic hooks (optional)	75
7 Scope of Delivery and Bed Variants	27	14.2 Linen Shelf (standard)	75
7.1 Delivery	27	14.3 Mobi-Lift® (optional)	76
7.2 Scope of Delivery	27	14.4 Brake Signal (optional)	77
7.3 Eleganza 4 Variants	27	14.5 i-Brake® (optional)	77
8 Putting into Service	28	14.6 Retractable Fifth Castor (optional)	77
8.1 Accumulator Activation	29	14.7 LINIS SafetyPort (optional)	77
8.2 Head Board and Foot Board	30	14.8 i-Drive Power (optional)	78
8.3 Mattress support platform	30	14.8.1 i-Drive Power System - Basic Description	78
8.4 Potential Equalisation	31	14.8.2 Safety instruction for i-Drive Power	78
8.5 Before Use	32	14.8.3 Specifications of Use	78
8.6 Transport	32	14.8.4 Manipulation	79
8.7 Firmware	32	14.8.5 i-Drive Power Activation/Deactivation	80
9 Power Cable	33	14.8.6 Powered Drive	80
10 Accumulator	33	14.8.7 Braking	81
10.1 Replacing the accumulator	34	14.8.8 Free Drive	81
10.2 Removing the Bed from Use	35	14.8.9 Accumulator	81
10.3 Deactivating the Accumulator	35	14.8.10 Fault Signalization	82
11 Manipulation	36	14.8.11 Light Indicators	82
11.1 Siderails	36	14.8.12 Technical Specifications	82
11.2 Castor Control	41	14.8.13 Electrical specification	83
11.3 CPR Backrest Release	42	14.8.14 i-Drive Power Maintenance	83
11.4 Control Elements	43	14.9 Safestop (optional)	83
11.4.1 Nurse Control Panel (optional)	44	14.10 X-Ray Examination (optional)	84
11.4.2 iBoard Basic (standard)	47	14.11 Undercarriage Cover	85
11.4.3 Attendant Control Panel	49	14.12 USB Connector (optional)	86
11.4.4 Handset (optional)	51	15 Mattress	87
11.4.5 Foot Switch - Bed Height (optional)	52	15.1 Installation of Passive Mattress	87
11.4.6 Patient Control Panels	52	15.1.1 Straps with side release buckles	87
11.5 Bed Positioning	53	15.2 Installation of Active Mattress	88
		15.2.1 Straps with side release buckles	88
		16 Accessories	90
		16.1 Lifting Pole	92
		16.2 Infusion Stand	93
		16.3 Oxygen Bottle Holder	94
		16.4 Ventilation Circuit Holder	95
		16.5 Writing Shelf	96
		16.6 Monitor Shelf	96

16.7 Urinary Bag Holder	97
16.8 Protectors	97
16.9 Safety Monitor	100
16.10 Traction Frame E	101
16.11 Pushing Handles	103
16.12 Pushing Handles with Holder of the i-Drive Power Control Panel	104
16.13 IDock (size S and size M)	106
17 Cleaning/Disinfection	108
17.1 Cleaning (Eleganza 4)	109
17.1.1 Daily Cleaning	109
17.1.2 Cleaning before Changing Patients	109
17.1.3 Complete Cleaning and Disinfection	110
18 Troubleshooting	110
19 Maintenance	111
19.1 Regular maintenance	111
19.2 Spare Parts	111
19.3 Safety Technical Checks	111
20 Disposal	112
20.1 Environment Protection	112
20.2 Disposal	112
20.2.1 Within Europe	112
20.2.2 Outside Europe	112
21 Warranty	113
22 Standards and Regulations	113

1 Symbols and Definitions

1.1 Warning Notices

1.1.1 Types of Warning Notices

Warning notices are differentiated by the type of danger using the following key words:

- ▶ **CAUTION** warns about the risk of material damage.
- ▶ **WARNING** warns about the risk of physical injury.
- ▶ **DANGER** warns about the risk of fatal injury.

1.1.2 Structure of Warning Notices



SIGNAL WORDS!

Type and source of danger!

- ▶ Measures to avoid the danger.

1.2 Instructions

Structure of instructions:







- ▶ Perform this step.
- Results, if necessary.

1.3 Lists

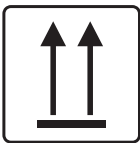





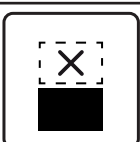



Structure of bulleted lists:



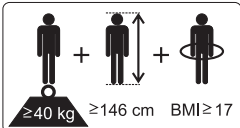
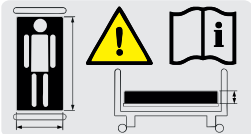

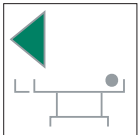







- List level 1
 - List level 2
 - List level 3







1.4 Symbols on the Package



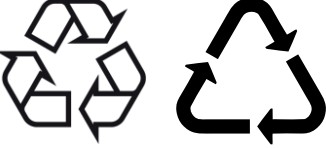

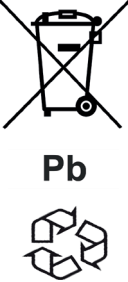

	<p>FRAGILE, HANDLE WITH CARE</p>
	<p>THIS WAY UP</p>
	<p>KEEP DRY (PROTECT FROM HUMIDITY)</p>
	<p>PAPER RECYCLING SYMBOL</p>
	<p>OVERSEAS PACKAGE: STACKING LIMIT BY NUMBER (4 PACKAGES FOR STORAGE)</p>
	<p>OVERSEAS PACKAGE: STACKING LIMIT BY NUMBER (2 PACKAGES FOR TRANSPORT)</p>
	<p>DO NOT USE HAND TRUCK HERE</p>
	<p>DO NOT STACK DURING STORAGE</p>







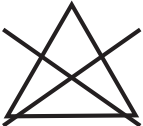
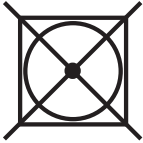
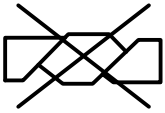
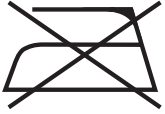

1.5 Symbols and Labels on the Bed

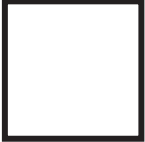
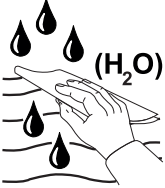
	<p>READ INSTRUCTIONS FOR USE</p>
	<p>GO BUTTON (PRESS TO ACTIVATE CONTROL ELEMENT)</p>
	<p>STOP BUTTON (PRESS TO INTERRUPT BED POSITIONING)</p>
	<p>SAFE WORKING LOAD</p>
	<p>DESIGNATION OF HOSPITAL BED FOR ADULTS</p>
	<p>USE MATTRESS RECOMMENDED BY MANUFACTURER</p>
	<p>DO NOT PUT ANY OBJECTS ON UNDERCARRIAGE</p>
	<p>BED EXTENSION</p>
	<p>WARNING AGAINST CRUSHING OR TRAPPING</p>
	<p>JACK FOR ATTACHMENT OF CONDUCTOR FOR POTENTIAL EQUALISATION</p>
	<p>CPR LEVER</p>
	<p>WARNING</p>

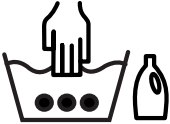
	<p>WARNING</p>
	<p>MAXIMUM CALFREST LOAD</p>
	<p>APPLIED PARTS TYPE B</p>
	<p>THERMAL PROTECTION FOR TRANSFORMER</p>
	<p>SAFETY ISOLATING TRANSFORMER, GENERAL</p>
	<p>ONLY SUITABLE FOR INDOOR USE</p>
	<p>MAXIMUM WEIGHT OF PATIENT</p>
	<p>WEIGHT OF BED</p>
	<p>CE MARK (ELEGANZA 4 WITHOUT SCALES)</p>
	<p>CE MARK (ELEGANZA 4 WITH SCALES)</p>
	<p>WEEE SYMBOL (RECYCLE AS ELECTRONIC WASTE, DO NOT PUT INTO THE HOUSEHOLD WASTE)</p>
	<p>MANUFACTURER</p>

	<p>DO NOT POLLUTE THE ENVIRONMENT</p>
	<p>RECYCLING SYMBOL</p>
	<p>DO NOT OPEN</p>
	<p>ON</p>
	<p>OFF</p>
	<p>BATCH NUMBER (ACCESSORIES)</p>
	<p>THIS COMPONENT CONTAINS LEAD - DO NOT PUT INTO THE HOUSEHOLD WASTE (Eleganza 4 bed is equipped with lead accumulator.)</p>
	<p>THIS COMPONENT CONTAINS LITHIUM - DO NOT PUT INTO THE HOUSEHOLD WASTE (If Eleganza 4 is equipped with Integration Module (SafetyMonitor System), it contains lithium battery.)</p>
	<p>MEDICAL DEVICE (compatible with Medical Device Regulation)</p>

	<p>MANUFACTURING DATE</p>
	<p>REFERENCE NUMBER (PRODUCT TYPE DEPENDING ON CONFIGURATION)</p>
	<p>SERIAL NUMBER</p>
	<p>DO NOT WASH (PROTECTOR COVER)</p>
	<p>DO NOT BLEACH (PROTECTOR COVER)</p>
	<p>DO NOT TUMBLE DRY (PROTECTOR COVER)</p>
	<p>DO NOT WRING (PROTECTOR COVER)</p>
	<p>DO NOT IRON (PROTECTOR COVER)</p>
	<p>PROFESSIONAL CHEMICAL CLEANING (MODERATE PROCEDURE)</p>
	<p>DO NOT USE PHENOL (PROTECTOR COVER)</p>

	<p>DRY NATURALLY (PROTECTOR COVER)</p>
	<p>RINSE WITH WATER (PROTECTOR COVER)</p>
	<p>DISINFECT USING SOLUTION CONTAINING LESS THAN 1000 ppm OF CHLORINE (REFER TO INSTRUCTIONS FOR USE) (PROTECTOR COVER)</p>
	<p>HANDWASH WITH DETERGENT (INITIAL TEMPERATURE OF HOT WATER SHOULD NOT EXCEED 50°C) (PROTECTOR COVER)</p>
	<p>COVER MATERIALS ARE FIRE RESISTANT TO BS7175, SOURCE 0, 1 AND 5 (PROTECTOR COVER)</p>
	<p>MASS OF MOBILE HOSPITAL BED (MASS OF EMPTY BED + SAFE WORKING LOAD)</p>
	<p>UK CONFORMITY ASSESSED (UKCA) MARKING (ONLY ELEGANZA 4 WITHOUT SCALES NORMATIVELY HARMONIZED FOR GREAT BRITAIN ECONOMIC AREA)</p>
	<p>AUTHORIZED REPRESENTATIVE IN GREAT BRITAIN</p>
	<p>AUTHORIZED REPRESENTATIVE IN SWITZERLAND</p>

1.6 Acoustic signalisation

SOUND	MEANING
CONTINUOUS SOUND	overheating
	accumulator overcurrent
	scales overload (only version with scales)
	actuator overload
REPEATED BEEP: 0,6s sound / 2,6s silence	STOP error (all STOP buttons are disabled)
MELODY: 3 beeps, pause, 2 beeps, longer pause, 3 beeps, pause, 2 beeps	Bed Exit Alarm (only version with scales)
BEEP lasting 0,3s	confirmation
	stopping or locked function
	optionally: transition from tilt (Trendelenburg, Antitrendelenburg) to horizontal position
BEEP lasting 0,5s	lowering to the lowest position
	start of service mode or end of service mode
	keyboard error (positioning blocked)
BEEP lasting 3s	system error
BEEP lasting 5s	scale module disconnected (only version with scales)
REPEATED BEEP during 3 minutes: 1,1s sound / 1,1s silence	Brake Signal (only version with Brake Signal)

1.7 Visual signalisation

1.7.1 NIGHT LIGHT

Bed illumination helps the nursing staff as well as the patient to orientate. The lowered intensity of lightning is set up after turning the bed on. The night light is turned off during accumulator operation.

The bed is equipped with three-phase illumination:

1. Lowered intensity of illumination
2. Full intensity of illumination
3. Illumination is turned off

After pressing any button:

- ▶ The bed illumination will light up at full intensity for 10 minutes. After 10 minutes the bed illumination will be lowered.
- ▶ After disconnection of the bed from the mains illumination lights up for few seconds.



Turning off bed illumination:

- ▶ Disconnect bed from the mains.
- ▶ After disconnection of the bed from the mains illumination lights up for few seconds.

1.7.2 Mains Power LED (Nurse Control Panel, Attendant Control Panel)

MAINS POWER LED 	MEANING
lit	connected to the mains
flashing: 0,6s lit / 0,6s not lit	keyboard error (flashing inverted to Lock LED) error (first fault)
flashing: 0,1s lit / 0,1s not lit	service mode
not lit	disconnected from the mains power transformer switching error

1.7.3 Accumulator indicator (Nurse Control Panel, Attendant Control Panel)

ACCUMULATOR INDICATOR  	MEANING
lit	accumulator disconnected or faulty
flashing: 1,6s lit / 0,2s not lit	accumulator deeply discharged
flashing: 0,1s lit / 0,1s not lit	accumulator discharged
flashing: 0,2s lit / 1,6s not lit	accumulator is charging
not lit	accumulator charged

1.7.4 Lock LED (Nurse Control Panel, Attendant Control Panel)

 LOCK LED	VISUAL SIGNALISATION		2 flashing modes in the case of the control element with single lock button: 1) flashing: 0,2s lit / 0,9s not lit 2) flashing: 0,1s lit / 0,1s not lit	flashing: 0,6s lit / 0,6s not lit			not lit
	lit			lock error	keyboard error	motion blocked	
Thighrest Lock LED	locked		1) lock settings - not selected lock 2) lock settings - selected lock	lock error	keyboard error	motion blocked	unlocked
Backrest Lock LED	locked		1) lock settings - not selected lock 2) lock settings - selected lock	lock error	keyboard error	motion blocked	unlocked
Bed Height, Trendelenburg and Antitrendelenburg Tilt Lock LED	locked		1) lock settings - not selected lock 2) lock settings - selected lock	lock error	keyboard error	motion blocked	unlocked
Foot Switch Lock LED	locked		1) lock settings - not selected lock 2) lock settings - selected lock	lock error	keyboard error	motion blocked	unlocked

1.8 Definitions

Basic Bed Configuration	the pricelist model configuration, not including a mattress
Bed Weight	The value depends on the product configuration, accessories or customer adjustments.
Clearance of Undercarriage	the height from the floor to the lowest point of the undercarriage between the castors, for the manipulation of accessories under a braked bed in the standard position
Duty Cycle	cycle of operation of the motor: time of activity/time of rest
Ergoframe	Ergoframe is the kinematic system of mattress support platform Adjustment whose effect is the elimination of pressure on the patient's abdomen and pelvic area and frictional forces on the patient's back and legs.
Maximum Patient Weight	Maximum Patient Weight depends on the application environment according to IEC 60601-2-52. For application environment 1 (intensive/critical care) and 2 (acute care) reduce Safe working Load by 65 kg. For application environment 3 (long-term care) and 5 (ambulatory care) reduce Safe working Load by 35 kg.
Safe Working Load	the highest allowable load on the bed (patient, mattress, accessories and the load supported by those accessories)
Siderail Height	the height of the upper crossbar or the edges of the siderails (not the highest point of the siderail controls) from the patient surface
Standard Bed Position	<ul style="list-style-type: none"> - The height of the patient surface with regard to the floor is 400 mm - The mattress support platform, including the individual parts, has to be in a horizontal (level - 0°) position. - The siderails are always locked in the upper position. - The basic position of the integrated extension.
Adult	Patient having a physical size equal to or more than 146 cm, a mass equal to or more than 40 kg and a body mass index (BMI) equal to or more than 17 (according to IEC 60601-2-52).
Mass of mobile hospital bed	Sum of empty bed mass and Safe Working Load.

1.9 Abbreviations

AC (~)	Alternating Current
ACP	Attendant Control Panel
CE	European Conformity
CPR	Cardiopulmonary Resuscitation
dBA	Sound Intensity Unit
DC (---)	Direct Current
CUC	Configuration number
EMC	Electromagnetic Compatibility
FET	Field-effect transistor
HF	High Frequency
HPL	High Pressure Laminate
HW	Hardware
ICU	Intensive Care Unit
INT.	Duty Cycle
IP	Ingress Protection
IV	Intravenous
LED	Light Emitting Diodes
ME	Medical Electrical (Equipment)
ON	Activation
OFF	Deactivation
ppm	parts per million, millionth (1000 ppm = 0,1%)
REF	Reference Number (product type depending on configuration)
SCU	System Control Unit (active mattress)
SN	Serial Number
SW	Software
SWL	Safe Working Load
UDI	Unique Device Identification (for medical devices)
USB	Universal Serial Bus
WEEE	Waste Electrical and Electronic Equipment

2 Safety Instructions



WARNING!
Eleganza 4 bed should be left in its lowest position when the patient is unattended in order to reduce risk of injury due to falls!



WARNING!
Siderails of Eleganza 4 should be located in the „up“ position to reduce the risk of the patient accidentally slipping or rolling off the mattress!



WARNING!
Incompatible siderails and mattresses can cause an entrapment hazard!



WARNING!
Inappropriate handling of the power supply cord, e. g. by kinking, shearing or other mechanical damages is hazardous!



WARNING!
When routing cables from other equipment in the Eleganza 4 bed avoid squeezing those between parts of the Eleganza 4 bed!



WARNING!
Eleganza 4 bed should not be used with bed hoists and bed lifts!



WARNING!
The bed is intended for adults.
► Follow the chapter **Intended use**.



WARNING!
Incompatible mattresses can create hazards.



WARNING!
To avoid the risk of electric shock, this equipment must only be connected to a supply mains with protective earth.



WARNING!
No modification of this equipment is allowed.



WARNING!
Do not modify this equipment without authorization of the manufacturer.



WARNING!
If this equipment is modified, appropriate inspection and testing must be conducted to ensure continued safe use of the equipment.



WARNING!
An additional multiple socket-outlet or extension cord shall not be connected to the medical electrical system.



WARNING!

During specific investigations or treatments the significant risks of reciprocal interference posed by ME equipment may occur.



WARNING!

Staff expert assessment is needed to consider all individual cases of contraindications!



WARNING!

Certain bed positions are not suitable for specific diagnosis/medical conditions. Fowler position is not suitable for spinal cord injuries! Trendelenburg position is not suitable for patients with higher intracranial pressure!



WARNING!

Length adjustment of the bed must be proportional to the height of patient!
Risk of trapping or squeezing because of patient's body constitution disproportionate to the size of mattress support platform!



WARNING!

Any serious incident that has occurred in relation to the device should be reported to the manufacturer and the competent authority of the Member State in which the user and/or patient is established!



WARNING!

Only authorised and trained person using the tool is allowed to change fuses and power supplies!



WARNING!

This medical device is not intended for oxygen enriched environment!



WARNING!

This medical device is not intended for use with flammable substances!



WARNING!

This medical device is not portable medical electrical equipment!



WARNING!

Make sure the duty cycle (2 min ON/18 min OFF) is not exceeded during bed positioning!



WARNING!

Patient is allowed to use selected control elements only if hospital personnel had assessed that the patient's physical and psychological state is in accordance with use of them and only if the hospital personnel had trained the patient in accordance with the instructions for use!



WARNING!

Hospital personnel is allowed to use the weighing system (scales) for weighing patients only if they had been trained according to the instructions for use!

Additional Instructions for Correct Use:

- ▶ Follow the instructions for use carefully.
- ▶ Use the bed exclusively if it is in perfect working order.
- ▶ If necessary, check the bed functions daily or at each shift change.
- ▶ Ensure any user has read and understood the instructions for use completely before operating the product.
- ▶ Use the bed exclusively with the correct mains supply.
- ▶ Ensure that the bed is operated exclusively by qualified personnel who have been trained according to the instructions for use.
- ▶ Ensure that the patient (health permitting) has been informed about the operation of the bed and all applicable safety instructions.
- ▶ Move the bed exclusively on even, hard-surfaced floors.
- ▶ Contact service department of the manufacturer immediately to let it replace any damaged parts by the original spare parts.
- ▶ Ensure that maintenance and installation are performed exclusively by qualified personnel who have been trained by the manufacturer.
- ▶ During peak loads or unavoidable excess loads (CPR), adjust Mattress support platform to the lowest position.
- ▶ Ensure that only one adult patient lies on the bed at any time.
- ▶ To avoid injury or crushing, take extra caution when operating any moving parts of the bed.
- ▶ When using lifting poles or infusion stands, ensure that nothing will be damaged when you move or adjust the bed.
- ▶ Brake the castors when the bed is occupied.
- ▶ Keep the mattress support platform in the lowest position at any time when the healthcare personnel are not treating the patient in order to prevent the patient from falling or injuries.
- ▶ Enable or disable functions on Patient Control Panels using the Attendant Control Panel as appropriate for the patient's physical and mental state. Verify that the function is actually disabled.
- ▶ Ensure that siderails are operated exclusively by healthcare personnel.
- ▶ Never use the bed in areas where there is a hazard of explosion.
- ▶ Never handle the mains plug with wet hands.
- ▶ Disconnect the product from the mains exclusively by pulling the mains plug.
- ▶ When pulling the mains plug, always hold the plug, not the cable.
- ▶ Position the mains cable so that there are no loops or kinks in the cable; protect the cable from mechanical wear and tear.
- ▶ Improper handling of mains cable can cause an electric shock hazard and other serious injuries or damages.
- ▶ To prevent failures, use exclusively the manufacturer's original accessories and mattresses in perfect working order.
- ▶ Ensure that the stipulated safe working load is not exceeded.
- ▶ If the patient's condition could lead to an entrapment, leave the mattress support platform in the flat position whilst unattended.
- ▶ Adjust bed height when transporting the bed in order to facilitate overcoming possible obstacles.
- ▶ Do not exceed maximum load of 80 kg for bed extension.
- ▶ Do not exceed the maximum patient weight limit (see Mechanical Specifications).
- ▶ Do not hang anything on any cable.
- ▶ Select a suitable location for the placement of bed accessories and other objects to prevent involuntary activation of buttons or controls which may result in the adjustment of bed positioning.
- ▶ Do not use the bed when its parts have been removed (e.g. parts of mattress support platform) unless these parts are designed to be removed.
- ▶ Never place any accessories or handset on the siderails where keyboards are located.
- ▶ After each emergency situation always check if any of the controllers (in siderails, handset or ACP) is not involuntarily pressed by the bed accessories or by the mattress.
- ▶ The weighing system must be calibrated at regular intervals and in accordance with the metrological regulations of the relevant country. All testing and certification must be carried out by qualified personnel. The healthcare provider is responsible for ensuring the required testing frequency and testing procedure of the weighing system is carried out.
- ▶ To avoid unintended activation of moving parts during any use of the bed always check that none of the control elements of the bed is pressed by persons, mattress or other objects.
- ▶ Before setting the Extra Low position, ensure there is no risk of any parts of the bed colliding with servers, accessories or body parts.
- ▶ Close Linen Shelf before using the Anti-Trendelenburg Tilt or Cardiac Chair Position.

3 Intended use

The intended use is the hospitalization of the patient in the intensive and acute care units, which includes above all the following aspects:

- ▶ Adjustment of the specific positions needed for the preventive reasons, routine nursing, treatments, mobilization, physiotherapy, examinations, sleeping, and relaxation. These positions are further specified and described in the clinical evaluation of this device, together with their potential clinical outcomes and benefits.
- ▶ Providing the safe environment for the patient during all relevant procedures. The particular requirements on patient safety are the subject of the clinical evaluation, including evaluation of the risk/benefit ratio. The relevant safety issues are the part of the risk management file.
- ▶ Patient in-bed indoor transport out of the patient room.
- ▶ Providing the suitable working conditions for the caregivers to perform the routine and specific tasks during the patient hospitalization.
- ▶ Indicative measurement of the patient weight, used as supportive feature without direct diagnostic effect. It helps staff to assess the general patient status and apply the nutrition and medicaments (valid for the version of the beds with in-bed scales).

3.1 User population

- ▶ Adult patients (weight ≥ 40 kg, height ≥ 146 cm, BMI ≥ 17) in the intensive and acute care units (Application Environment 1 and 2 as in IEC 60601-2-52)
- ▶ Caregivers (nurses, doctors, technical personnel, transport personnel, cleaning personnel)

3.2 Contraindications

- ▶ The medical device is not intended for the pediatric patients use.
- ▶ Certain positions are not suitable for specific diagnoses/medical conditions (e.g. spinal cord injuries vs. Fowler position, higher ICP patients vs. Trendelenburg). Staff expert assessment / nursing consideration is needed in all individual case of contraindication.

3.3 Operator

- ▶ Caregiver
- ▶ Patient (based on individual patient status assessment by caregiver the patient can utilize dedicated device functions)

4 Product Description

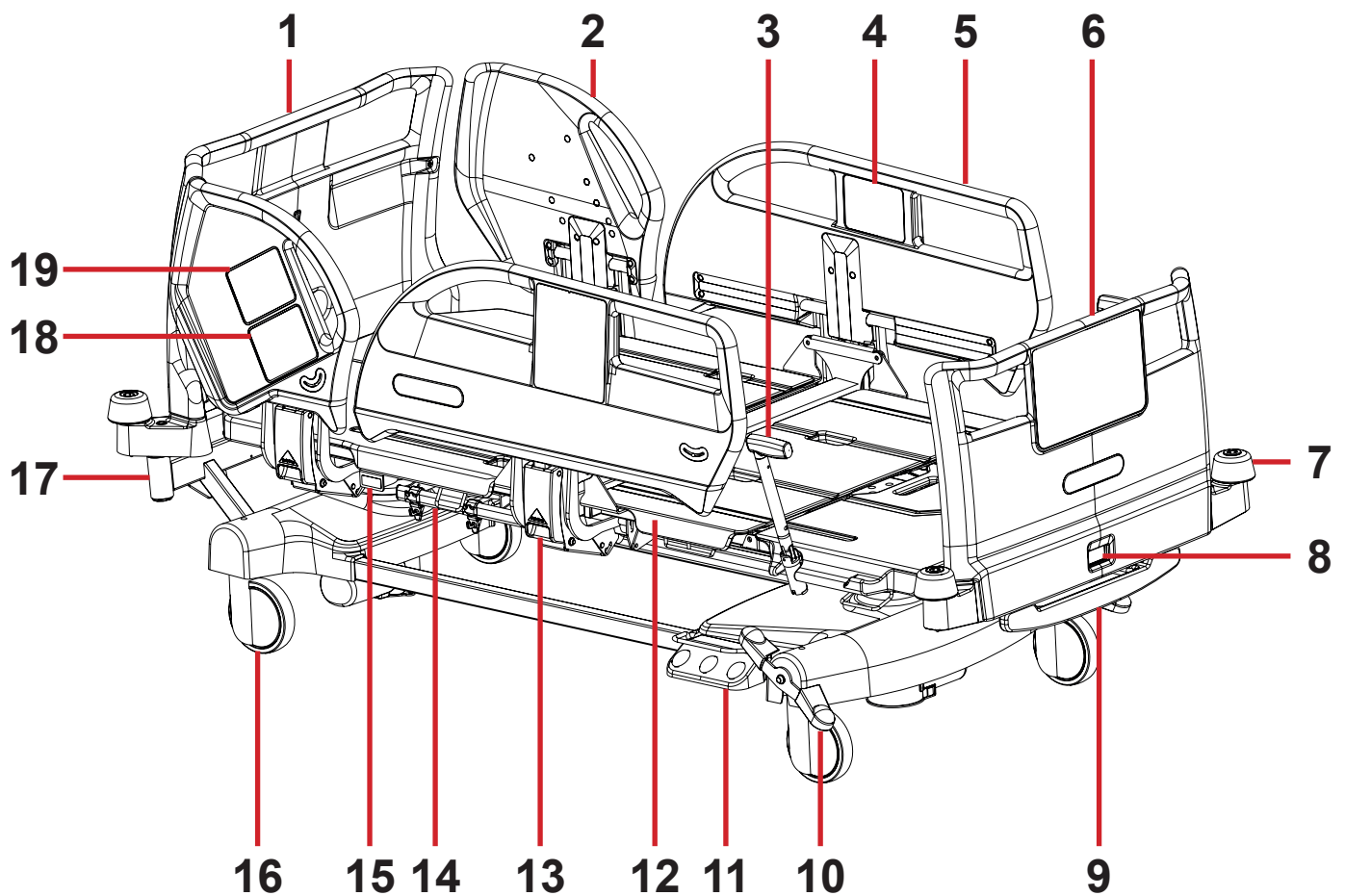

Fig. Bed Overview (Eleganza 4)

- 1. Removable Head Board
- 2. Head Siderail
- 3. Mobi-Lift Handle - Bed Height
- 4. Patient Control Panel
- 5. Foot Siderail
- 6. Removable Foot Board
- 7. Corner Bumper
- 8. Foot Board Lock
- 9. Linen Holder
- 10. Castor Control Lever
- 11. Foot Switch - Bed Height
- 12. Four-part Mattress support platform with Ergoframe® System
- 13. Siderail Release Mechanism
- 14. Accessory Rail
- 15. CPR Lever – Backrest Release
- 16. Castor
- 17. Accessory Adaptor
- 18. Nurse Control Panel
- 19. iBoard Basic

5 Technical Specification

All technical data are rated data and are subject to construction and manufacturing tolerances.

5.1 Identification of Applied Parts (Type B)

All part of the bed (and accessories) the patient can reach are type B Applied Parts.

- Mattress support platform Frame, Covers and all Movable Parts
- Head and Foot End
- Siderails
- Mobi-Lift® Handles
- Handset
- Patient Control Panels

5.2 Scales

Accuracy of displayed weight values:

- 0,5 kg
- Scales Class III

5.3 Mechanical Specifications (Eleganza 4)

Parameter	Value
External Dimensions in Standard Bed Position (length x width)	217,5 cm x 100 cm
Maximum Siderail Height above Mattress support platform	45 cm
Dimensions of Head Siderail (length x height)	51,1 cm x 46,8 cm
Dimensions of Foot Siderail (length x height)	100,2 cm x 43,1 cm
Bed Extension	11 cm, 22 cm
Maximum Dimensions of Mattress (length x width)	208 cm x 90 cm
Maximum Mattress Height	23 cm
Clearance of Undercarriage	15 cm
Castor diameter	15 cm
Minimum-Maximum Mattress support platform Height (above floor, without Mattress)	41 cm - 79 cm
Ergoframe (Backrest/Thighrest)	7,4 cm / 4 cm
Maximum Backrest Angle	65°
Maximum Thighrest Angle	25°
Maximum Calfrest Angle	20°
Angle between Calfrest and Thighrest	225°
Trendelenburg Angle	14°
Anti-Trendelenburg Angle	14°
Bed Weight (depending on configuration)	195 Kg
SWL (Bed Safe Working Load)	250 Kg
SWL (Lifting Pole Safe Working Load)	75 Kg
Maximum Patient Weight	185 Kg
Mass Of Mobile Hospital Bed (mass of empty bed + safe working load)	476 Kg
Sound Pressure Level	57 dBA
Minimum Sound Pressure Level of Bed Exit Alarm	60 dBA

5.4 Environment Conditions

Use Conditions	
Ambient Temperature	10°C - 40°C
Relative Humidity	30% - 75 %
Atmospheric Pressure	795 hPa - 1060 hPa
Storage and Transport Conditions	
Ambient Temperature	-20°C - 50°C
Relative Humidity	20% - 90 %
Atmospheric Pressure	795 hPa - 1060 hPa

5.5 Electrical Specifications (Eleganza 4)

Parameter	Value
Input Voltage	
Version 1	230 V~, 50/60 Hz
Version 2	100 V~, 50/60 Hz
Version 3	110 V~, 50/60 Hz
Version 4	120 V~, 50/60 Hz
Version 5	127 V~, 50/60 Hz
Version 6	110 - 127 V~, 60 Hz or 220 V~, 50/60 Hz
Maximum Power Input	370 VAC
Ingress Protection (EN 60529)	IP X4
Protection Class	Class I
Electrical Motor Duty Cycle	2 minutes ON /18 minutes OFF
Accumulator	Pb AKU 2 x 12 V / 1,2 Ah / Fuse 15 A
Fuse (version without i-Drive Power)	
Version 1	2x T1.6A L 250 V for 230 V, 110-127 V or 220 V version
Version 2	2x T3.15A L 250 V for 100 V, 110 V, 120 V, 127 V, 110-127 V or 220 V version
Fuse (version with i-Drive Power)	
Version 1	2 x T2A L 250V for 230 V
Version 2	2 x T4A L 250V for 100 V, 110 V, 120 V, 127 V

NOTE Upon request, LINET ® can deliver hospital beds with electrical specifications that comply with regional standards (custom voltage, different mains plugs).

5.6 Electromagnetic Compatibility

Bed is intended for hospitals except for near active HF surgical equipment and the RF shielded room of a medical system for magnetic resonance imaging, where the intensity of EM disturbances is high.

Bed has defined no essential performance.



WARNING!

It is recommended to avoid the use of this device next to or in block with other device, because it could lead to improper operation. If such use is needed, this device and the other equipment should be under surveillance to verify proper operation.

List of used cables:

- ▶ **Mains cable**, maximum length 6 m
- ▶ **Attendant Control Panel**, maximum length 3m
- ▶ **Handset**, maximum length 3m



WARNING!

Use of the accessories, converters and other cables, than specified and provided by manufacturer of this bed could lead to increase of electromagnetic emission or lower the electromagnetic immunity of this bed and lead to improper operation.



WARNING!

Mobile RF communication device (including end use devices like antenna cables and external antenna) should not be used closer than 30 cm (12 inches) from any part of this bed Eleganza 4, including cables specified by manufacturer. Otherwise this could lead to deterioration of functionality of this bed.



WARNING!

Do not overload the bed (SWL), respect the duty cycle (INT.) and consider chapter 19 Maintenance in order to maintain the basic safety with regard to electromagnetic disturbances for the expected service life.

5.6.1 Manufacturer instructions - electromagnetic emissions

Emission Test	Compliance
RF emissions CISPR 11	Group 1
RF emissions CISPR 11	Class B
Harmonic emissions IEC 61000-3-2	Class A
Voltage fluctuations / flicker emissions IEC 61000-3-3	Complies

5.6.2 Manufacturer instructions - electromagnetic susceptibility

Immunity Tests	Compliance level
Electrostatic discharge (ESD) IEC 61000-4-2	± 8 kV for contact discharge ± 15 kV for air discharge
Radiated RF IEC 61000-4-3 Proximity fields from RF wireless communications equipment IEC 61000-4-3	3 V/m 80 MHz – 2,7 GHz 80 % AM at 1 kHz See Table 1
Fast electrical transients / burst IEC 61000-4-4	±2 kV for power line repetition frequency 100 kHz
Surge IEC 61000-4-5	± 1 kV Line-to-line ± 2 kV Line-to-ground
Conducted RF IEC 61000-4-6	3 V (0,15 MHz – 80 MHz) 6 V in ISM bands between 0,15 MHz and 80 MHz 80 % AM at 1 kHz
Power frequency (50/60 Hz) magnetic field IEC 61000-4-8	30 A/m
Voltage dips, short interruptions on power supply input lines IEC 61000-4-11	0 % UT; 0,5 cycle At 0°, 45°, 90°, 135°, 180°, 225°, 270° and 315° 0 % UT; 1 cycle and 70 % UT; 25/30 cycle Single phase: at 0° 0 % UT; 250/300 cycle

Table 1 - IMMUNITY to RF wireless communications equipment

Test frequency (MHz)	Band (MHz)	Service	Modulation	Immunity Test Level V/m
385	380 - 390	TETRA 400	Pulse modulation 18 Hz	27
450	430 - 470	GMRS 460, FRS 460	FM ± 5 kHz deviation 1 kHz sine	28
710 745 780	704 - 787	LTE band 13, 17	Pulse modulation 217 Hz	9
810 870 930	800 - 960	GSM 800/900, TETRA 800, iDEN 820, CDMA 850, LTE band 5	Pulse modulation 18 Hz	28
1 720 1 845 1 970	1 700 - 1 990	GSM 1800; CDMA 1900; GSM 1900; DECT; LTE band 1, 3, 4, 25; UMTS	Pulse modulation 217 Hz	28
2 450	2 400 - 2 570	Bluetooth, WLAN, 802.11 b/g/n, RFID 2450, LTE band 7	Pulse modulation 217 Hz	28
5 240 5 500 5 785	5 100 - 5 800	WLAN 802.11 a/n	Pulse modulation 217 Hz	9

NOTE There are applied no deviations to requirements of IEC 60601-1-2 ed. 4

NOTE There are no known other measures for keeping the basic safety based on EMC phenomena.

NOTE Beds equipped with communication module meet standard for IEEE 802.11 b/g/n (2400,0 MHz – 2483,5 MHz, modulation DSSS (IEEE 802.11 b), OFDM (IEEE 802.11 g/n) 20MHz bandwidth, EIRP = 0,34 W).

6 Use and Storage Conditions



DANGER!

Danger to life due to electric shock!

To ensure the bed's class I protection against electric shocks:

- ▶ Ground the mains.
- ▶ Use exclusively Hospital Grade or Hospital Only receptacles for grounding.

Eleganza 4 is designed for use in rooms for medical purposes. Electrical installations must therefore meet local norms laying down the necessary conditions for electrical installations.

- ▶ Disconnect the bed from the mains in exceptional cases (i.e. lightnings, earthquake).

Eleganza 4 is not suitable for indoor environments containing flammable gases (except oxygen cylinders).

7 Scope of Delivery and Bed Variants

7.1 Delivery

- ▶ Upon receipt, check that the shipment is complete as specified on the delivery note.
- ▶ Notify the carrier and supplier of any deficiencies or damages immediately as well as in writing or make a note on the delivery note.

7.2 Scope of Delivery

- Eleganza 4 hospital bed
- Instructions for use

7.3 Eleganza 4 Variants

s = standart

o = optional

Variable bed features:

- Scales
 - without scales (without Bed Exit Monitoring) (o)
 - with scales (with Bed Exit Monitoring or with SafetyMonitor) (s)
- Castors
 - Tente Integral 150 mm (5.9 in.) single castors (s)
 - Tente Integral 150 mm (5.9 in.) double castors (o)
 - Tente Integral 150 mm (5.9 in.) single castors + retractable 5th castor (o)
 - Tente Integral 150 mm (5.9 in.) double castors + retractable 5th castor (o)
- Control Elements
 - Nurse Control Panel in both head siderails (o)
 - iBoard Basic in both head siderails (s)
 - Attendant Control Panel (s)
 - Patient Control Panel in both foot siderails (o)
 - Handset with illuminated buttons and adapter for simple connection Plug and Play (o)
 - Foot Switch - Bed Height (o)
- Undercarriage Cover
 - 2-part undercarriage cover (s)
 - 1-part undercarriage cover (o)
- Linen Shelf (s)
- 1 pair of Mobi-Lift® handles (o)
- Night Light (o)
- Brake Signal (o)
- i-Brake® (o)
 - without Brake Signal (o)
 - with Brake Signal (o)
- x-ray cassette holder (o)
- EMR ready bed (o)
- USB (o)
- Safestop (o)
- i-Drive Power (o)
- LINIS SafetyPort
 - without LINIS SafetyPort (s)
 - basic hardware preparation for LINIS SafetyPort (CE06: without Integration Module) (o)
 - complete hardware preparation for LINIS SafetyPort (CE31: with Integration Module) (o)
- Bed ready for Protectors (o)

NOTE It is not possible to equip the Eleganza 4 bed with Attendant Control Panel and with Nurse Control Panel at the same time.

8 Putting into Service



WARNING!

Risk of injury when working on the bed!

- ▶ Ensure that the bed is disconnected from the mains connection prior to putting into service, putting out of service and maintenance.
- ▶ Ensure that the castors are locked prior to putting into service, putting out of service and maintenance.



CAUTION!

Material damage due to incorrect putting into service!

- ▶ Ensure that putting into service is performed exclusively by manufacturer's customer service or trained hospital personnel.



CAUTION!

Material damage due to temperature difference!

- ▶ If there is a considerable temperature difference between the bed and the place of operation (after transport/storage), leave bed unconnected for 24 hours for the difference to balance itself.

NOTE For safe, easy handling, LINET ® recommends having two technicians assemble the bed.

Set up the bed as follows:

- ▶ Unpack the bed.
- ▶ Check the delivery (see Scope of Delivery and Bed Variants).
- ▶ Remove isolating foil from the mains control box (see Accumulator Activation).
- ▶ Install equipment and accessories.
- ▶ In case of delivery with dismantled bed ends, mount the head and foot ends (see Head Board and Foot Board).
- ▶ Set up the bed exclusively on a suitable floor surface (see Transport).
- ▶ Ensure that the mains cable does not collide or get stretched when adjusting the bed.
- ▶ Check that the plug is inserted correctly.
- ▶ Do not leave any extension cords or power strips loose on the floor.
- ▶ Ensure that all of the required mechanical and electrical prevention mechanisms are available on site.
- ▶ There is no mains switch on the bed, i.e. the mains cable is the only means to isolate the bed from the mains. Ensure that the mains cable is always accessible.
- ▶ Have the separable plug of the mains cable changed and maintained exclusively by qualified and trained service technicians authorised by the manufacturer.

8.1 Accumulator Activation

Control Section Placement

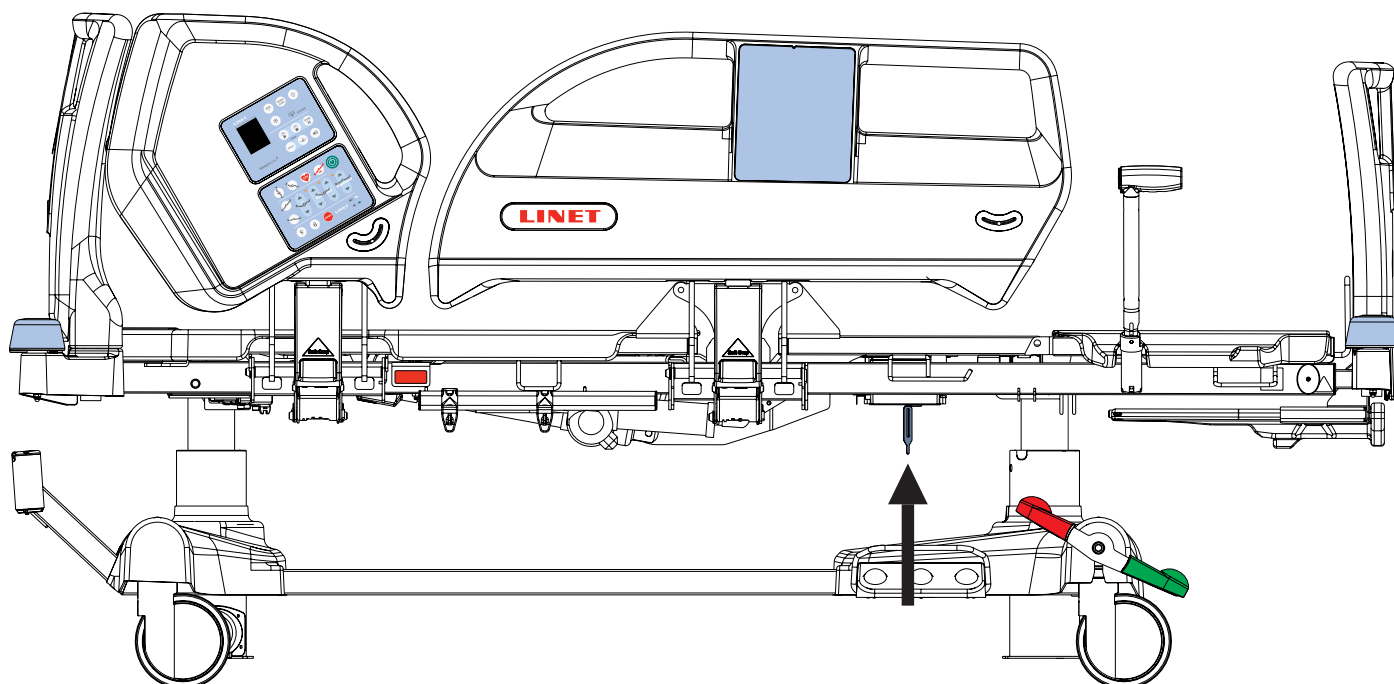

Fig. Position of Isolating foil

Removing the Isolating Foil

To remove isolating foil:

- ▶ Remove isolating foil from mains control box by pulling strap.
- ▶ Check if isolating foil is complete and undamaged as shown.
- ▶ If isolating foil is damaged, contact the manufacturer's service department immediately.

NOTE It is recommended to wear gloves when removing the isolating foil.

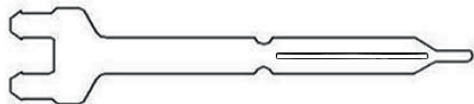

Fig. Detail of Isolating Foil

8.2 Head Board and Foot Board

Remove head board or foot board as follows:

- ▶ Unlock Head Board Lock or Foot Board Lock.
- ▶ Pull head board or foot board from sleeve fitting.
- ▶ Lock Head Board Lock or Foot Board Lock.

Install head board or foot board as follows:

- ▶ Unlock Head Board Lock or Foot Board Lock.
- ▶ Slide head board or foot board into sleeve fitting.
- ▶ Lock Head Board Lock or Foot Board Lock.

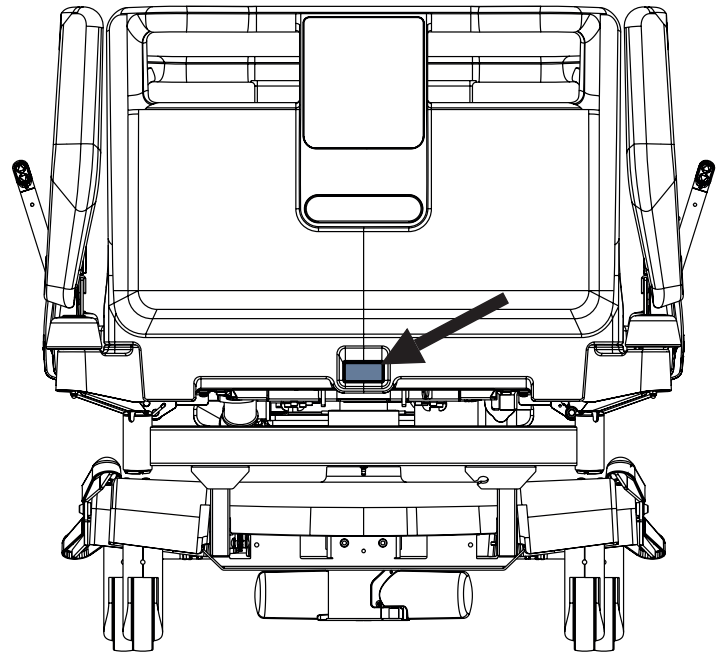

Fig. Head Board Lock

8.3 Mattress support platform

Eleganza 4 bed has 4-part Mattress support platform consisting of Backrest, Seat section, Thighrest and Calfrest. The Mattress support platform without x-ray cassette holder has 4 removable covers of Mattress support platform (1, 2, 3 and 4).

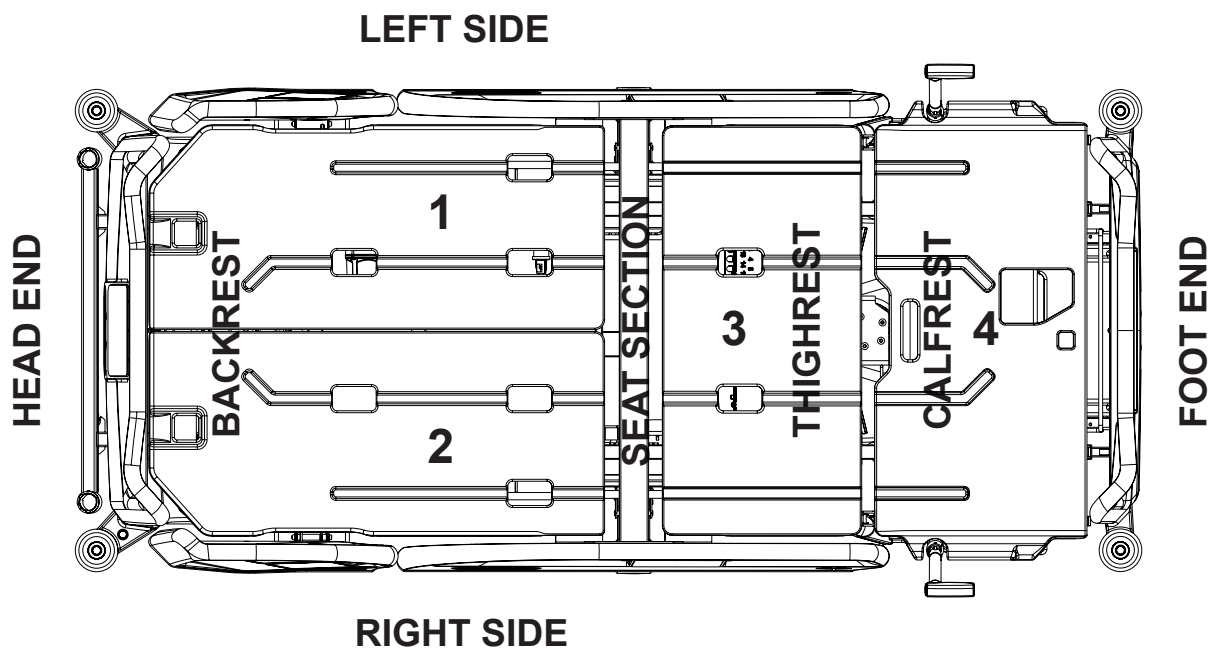

Fig. 4-part Mattress support platform

8.4 Potential Equalisation

The bed is equipped with a standard protective connector. This connector is used for potential equalisation between the bed and any intravascular or intracardiac device connected to the patient to protect the patient from static electric shocks.

Use equalisation connector if:

- the patient is connected to any intravascular or intracardiac device.

Before connecting the patient to an intravascular/intracardiac device:

- ▶ Connect the ground wire of the device to the potential equalisation connector on the bed on which the patient in question is lying.
- ▶ Use a standard hospital connector.
- ▶ Make sure that the connectors match.
- ▶ Make sure that there is no possibility for inadvertent disconnection.

Before moving the bed:

- ▶ Disconnect the patient from the intravascular or intracardiac device.
- ▶ Disconnect the potential equalisation connector.

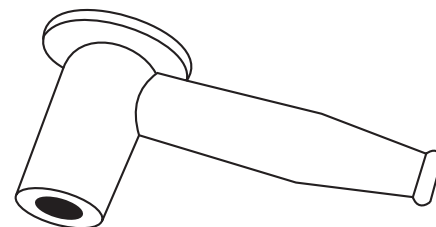

Fig. Potential equalisation connector - female

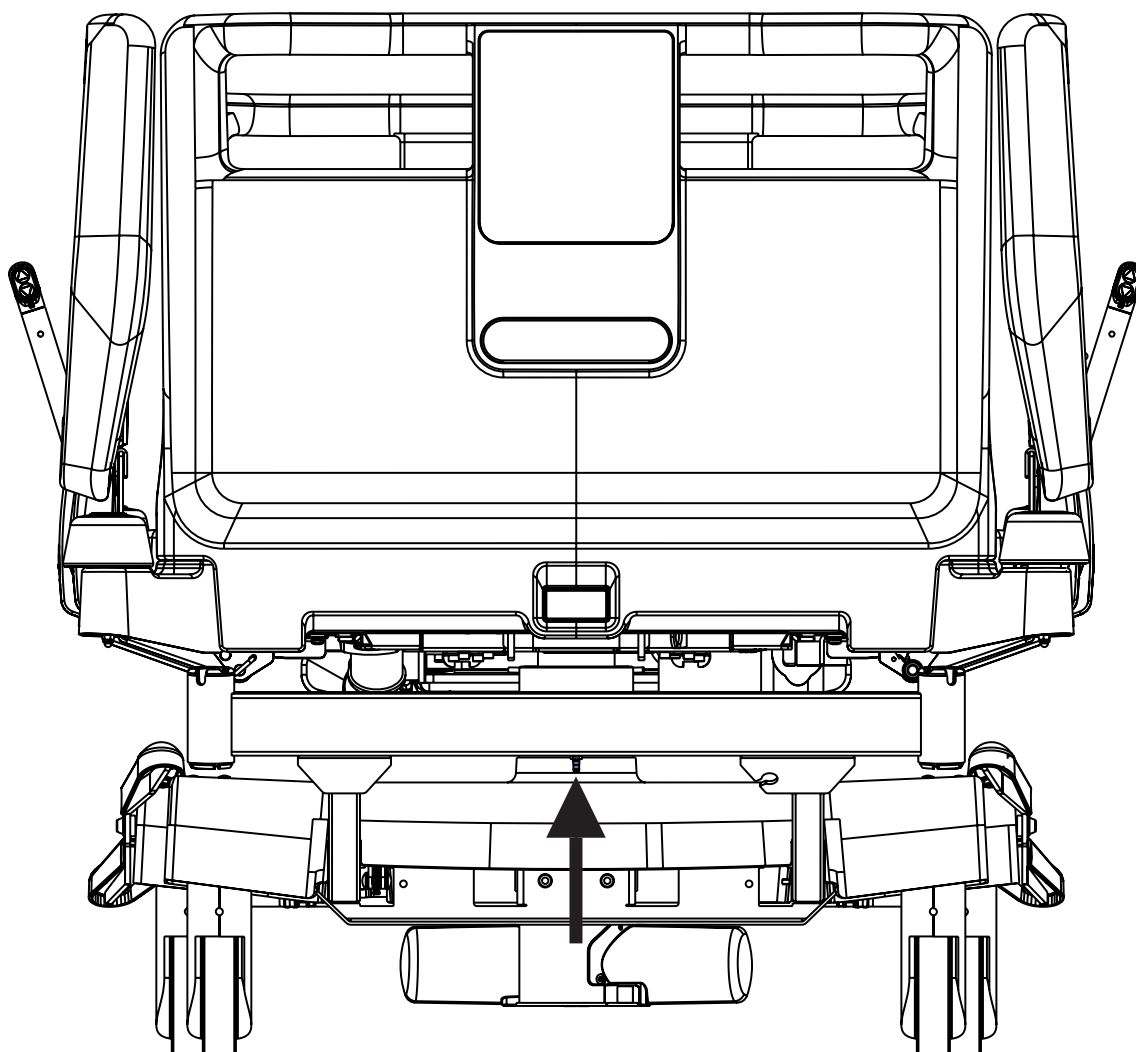

Fig. Potential equalisation - male

8.5 Before Use

Prepare the bed for use as follows:

- ▶ Connect the bed to the mains.
- ▶ Charge the accumulator.
- ▶ Raise and tilt the mattress support platform to the highest position.
- ▶ Lower and tilt the mattress support platform to the lowest position.
- ▶ Check that the castors as well as main brake work correctly.
- ▶ Check that the bed extension works correctly.
- ▶ Check that it is possible to remove the head and foot boards.
- ▶ Check all of the functions on the control elements.
- ▶ Check that the siderails function properly.
- ▶ Dispose of all packaging (see Disposal).

8.6 Transport

For a safe transport, observe the following:

- ▶ Ensure that no cables are run over when moving a bed.
- ▶ Ensure that the mains cable is attached with a hook (at the head end of the bed).
- ▶ Ensure that the castors are unlocked before moving the bed during the loading/unloading process (see Castor Control).
- ▶ Adjust bed height to at least 20 cm below maximum height.
- ▶ Push bed by handles on head or foot end.
- ▶ Move the bed exclusively on suitable floor surfaces.
- ▶ For longer distances, ensure that the castor steering function is activated.
- ▶ Ensure that the brakes are released while moving the bed.

Suitable surfaces:

- Tile
- Hard linoleum
- Poured flooring

Unsuitable surfaces:

- Too soft, unsealed or defective flooring
- Soft wooden flooring
- Soft and porous stone floors
- Carpeted floors with underlay
- Soft linoleum

8.7 Firmware

The bed includes firmware that can be updated only by an authorised service technician.

This firmware is protected against unauthorised access by mechanical housing (tool is needed to access), by seal (components with processor are sealed), by exclusive compatibility with an authorised software tool and by check of compatibility of the new firmware with the bed.

9 Power Cable

Attachment plug is means of connecting and disconnecting bed from the mains.
Mains power cable must be attached with a hook at the head end of the bed during transport.



CAUTION!

Disconnecting bed from the mains does not stop motions of the bed!

- ▶ Stop the bed before disconnection bed from the mains.

Where the integrity of the external protective conductor in the installation or its arrangement is in doubt

- ▶ operate the bed from internal accumulator only.

10 Accumulator



WARNING!

When the bed is not connected to the mains and accumulator is not sufficiently charged all electrical functions of the bed are blocked!

Purpose

The accumulator serves as a backup during power failures, during transport of patient or for emergency bed positioning.

- ▶ Use only accumulator approved by the manufacturer.
- ▶ Check the functionality of the accumulator at least once a month in accordance with the instructions for use and have the accumulator changed if necessary.

The manufacturer will assume no responsibility for any damage to the bed or the accumulator caused by:

- non-observance of the manufacturer's instructions in the instructions for use
- using accumulator not approved by the manufacturer

Warranty

The manufacturer provides a **6-month** warranty for the full function of the accumulator.

Accumulator lifetime could be up to 5 years if operated under optimum conditions.

Accumulator capacity can be significantly reduced if:

- ▶ too high ambient temperature
- ▶ many accumulator charge/discharge cycles
- ▶ recurrence of deep discharge
- ▶ bed is often powered only by the accumulator

Charging

The accumulator supplied with the bed is delivered insufficiently charged.

Charging of the accumulator before use of the bed takes approximately 4 hours.

Charging of the accumulator runs automatically when the power cable is connected to the mains.

To charge the accumulator:

- ▶ Connect the bed to the mains.

Storage

For declared lifetime period of leaded accumulator is recommended during storage:

- ▶ To prevent accumulator from deep discharging and to keep accumulator at least partly charged by regular recharging
- ▶ To store accumulator on the places with temperature from 10°C to 40°C
- ▶ To prevent accumulator from being in the sunshine

Signalisation

The LED (on Nurse Control Panel or Attendant Control Panel) indicates the accumulator charge status:

Yellow LED	Accumulator charge status
Not lit	Accumulator capacity is sufficient (charging completed)
Short flashing (shortly lit, longer not lit) (circa 1.8 sec.)	Accumulator is charging - continue charging until the LED is extinguished. In emergency cases, the accumulator can be used as a backup power source for a short period. If LED is still flashing after 12 hours of charging or stops flashing, but you can not position with bed, accumulator is defective or broken. Contact manufacturer.
Short flashing (0,2s lit, 0,2s not lit)	Only CPR function can be used.
Long flashing (longer lit, shortly not lit) (circa 0.2 sec.)	Low accumulator voltage - accumulator can not be used as a backup power supply even for a short period; accumulator is completely discharged or defective (if this type of signalisation persists, it is necessary to replace the accumulator - service action)
Lit continuously, when bed is connected to the mains.	Accumulator absence or failure condition (accumulator is connected incorrectly, line between the power supply and accumulator is broken or accumulator fuses are faulty); contact service department of the manufacturer in case of such signalisation.

10.1 Replacing the accumulator



CAUTION!

Damage to the bed due to incorrect accumulator replacement!

- ▶ Have the accumulator replaced exclusively by qualified personnel.
- ▶ Exclusively use accumulator approved by the manufacturer.



CAUTION!

Material damage due to overheating!

If the accumulator is faulty, degassing may occur. In rare cases this might cause deformations of the accumulator case, control panel housing or cable.

- ▶ Stop using the bed immediately (see Removing the Bed from Service).
- ▶ Inform the manufacturer's service department.



CAUTION!

Risk of reducing accumulator durability due to incorrect use!

- ▶ Use bed on accumulator only in crisis situations (e.g.: power blackout, patient complications during transport, etc.)
- ▶ After reconnecting bed to the mains charge accumulator to full capacity (see chart Accumulator charge status).
- ▶ Have accumulator replaced exclusively by a qualified service organisation.
- ▶ The manufacturer recommends to replace the accumulator by qualified service organization after 2 years of use.

After this period the supposed service life of accumulator ends and the manufacturer cannot guarantee the accumulator service life after this period.

Faulty accumulator

This status is indicated by the accumulator status indicator being constantly lit.

The accumulator is regarded as faulty if at least one of the following conditions applies:

- ▶ Accumulator charging constantly
- ▶ Low voltage on accumulator
- ▶ Low charging current of accumulator

NOTE These statuses are summarised and written to black box in control unit.

To cancel this status:

- ▶ Press button  .

Discharged accumulator

This status will be cancelled automatically when the bed switches to sleep mode.

The accumulator is regarded as discharged if the following condition is met:

- ▶ Defined decrease of voltage depending on discharging current
- ▶ This status is indicated by the accumulator status indicator flashing quickly.
- ▶ It is possible to use the electric CPR only to position the bed.

To cancel this status:

- ▶ Press button  .

10.2 Removing the Bed from Use

Remove the bed from use as follows:

- ▶ Disconnect the bed from the mains.
- ▶ Disconnect the ground wire.
- ▶ Deactivate the accumulator.
- ▶ Remove accessories.

To prevent damage during storage:

- ▶ Pack or cover the bed and accessories.
- ▶ Ensure that storage conditions are the same as the operating conditions.

10.3 Deactivating the Accumulator

To avoid damaging the bed and the environment during storage:

- ▶ Deactivate the accumulator.

To deactivate the accumulator:

- ▶ Disconnect the bed from the mains.
- ▶ Disconnect the ground wire.
- ▶ Activate the keypad by pressing the button  .
- ▶ Press the Thighest Up + Thighest Down + Trendelenburg Tilt buttons at the same time and hold them for 3 seconds. The accumulator is deactivated.

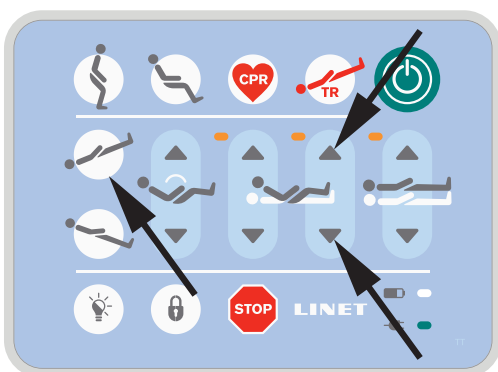

Fig. Deactivation of the accumulator (Nurse Control Panel)

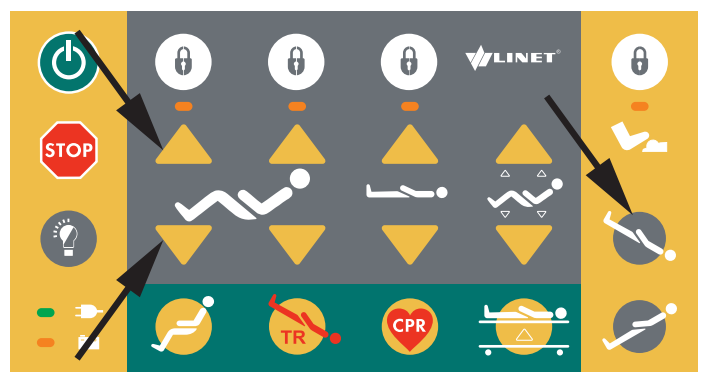

Fig. Deactivation of the accumulator (Attendant Control Panel)

To activate the accumulator again:

- ▶ Connect Power Cable to the mains.

11 Manipulation



WARNING!

Risk of injury when adjusting the bed!

- ▶ Ensure that there are no body parts between the mattress support platform elements and the mattress support platform frame when adjusting the bed.
- ▶ Ensure that there are no body parts below the mattress support platform frame before adjusting the bed.

11.1 Siderails

The split siderails are components of the bed in contact with patient. A pneumatic spring supports the operation of the split siderails. The nursing personnel are responsible for the siderails being raised up while the patient is in bed.



WARNING!

Risk of injury, damaging or unintentional movement of the bed due to incorrect placement of accessories or Handset!

- ▶ Never place any accessories or Handset on the siderails in the area where keyboards are located.
- ▶ Never place Handset on the edge of siderail.

The correct placement of Handset is shown at following pictures.



WARNING!

Risk of injury due to incorrectly latched siderail!

- ▶ Ensure that siderail is secured in the upper or lower position.



WARNING!

Risk of injury due to incorrect position of siderails!

- ▶ Ensure that siderails are folded up while the patient is in bed.

SIDERAIL DESCRIPTION (version with Nurse Control Panel and iBoard Basic)

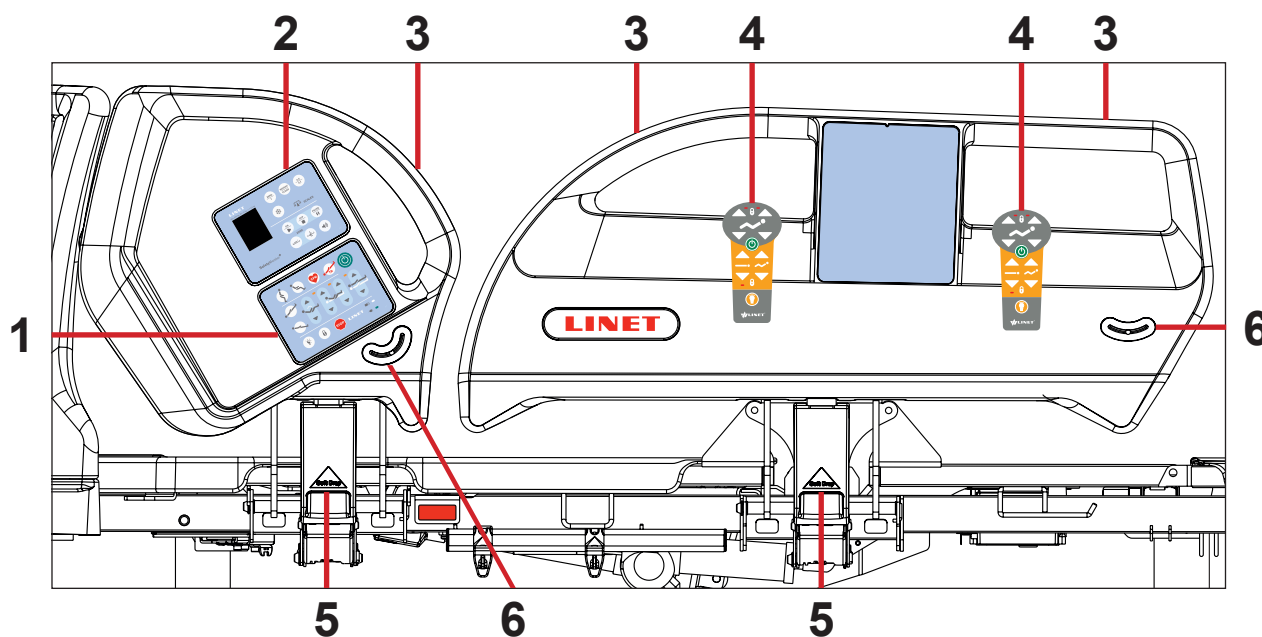

Fig. Siderails (version with Nurse Control Panel and iBoard Basic)

- 1. Nurse Control Panel
- 2. iBoard Basic
- 3. Siderail Handle
- 4. Correct Placement of Handset
- 5. Siderail Release Handle
- 6. Angle Indicator

MANIPULATION

To raise siderails up:

- ▶ Grab siderail by Siderail Handle (3).
- ▶ Pull siderail up until it latches. You will hear audible „click“.

To release siderails down:

- ▶ Grab siderail by Siderail Handle (3).
- ▶ Unlock siderail by pulling Siderail Release Handle (5) to yourself.
- ▶ Fold down siderail slowly.

SIDERAIL DESCRIPTION (version with Nurse Control Panel)

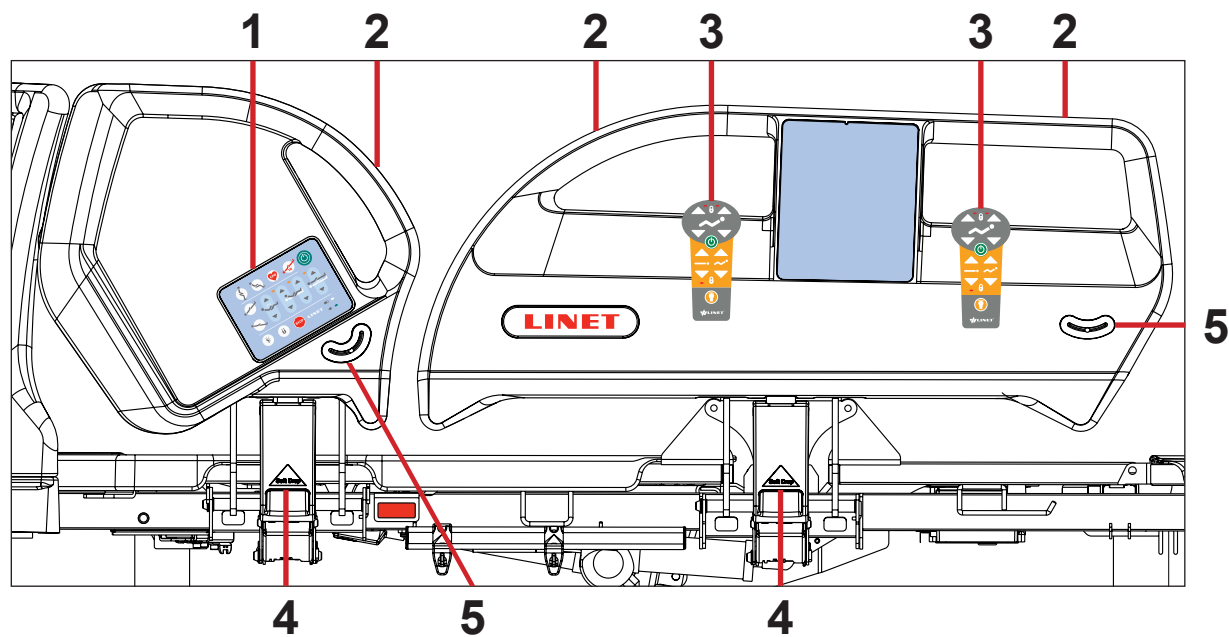

Fig. Siderails (version with Nurse Control Panel)

- 1. Nurse Control Panel
- 2. Siderail Handle
- 3. Correct Placement of Handset
- 4. Siderail Release Handle
- 5. Angle Indicator

MANIPULATION

To raise siderails up:

- ▶ Grab siderail by Siderail Handle (2).
- ▶ Pull siderail up until it latches. You will hear audible „click“.

To release siderails down:

- ▶ Grab siderail by Siderail Handle (2).
- ▶ Unlock siderail by pulling Siderail Release Handle (4) to yourself.
- ▶ Fold down siderail slowly.

SIDERAIL DESCRIPTION (version with iBoard Basic)

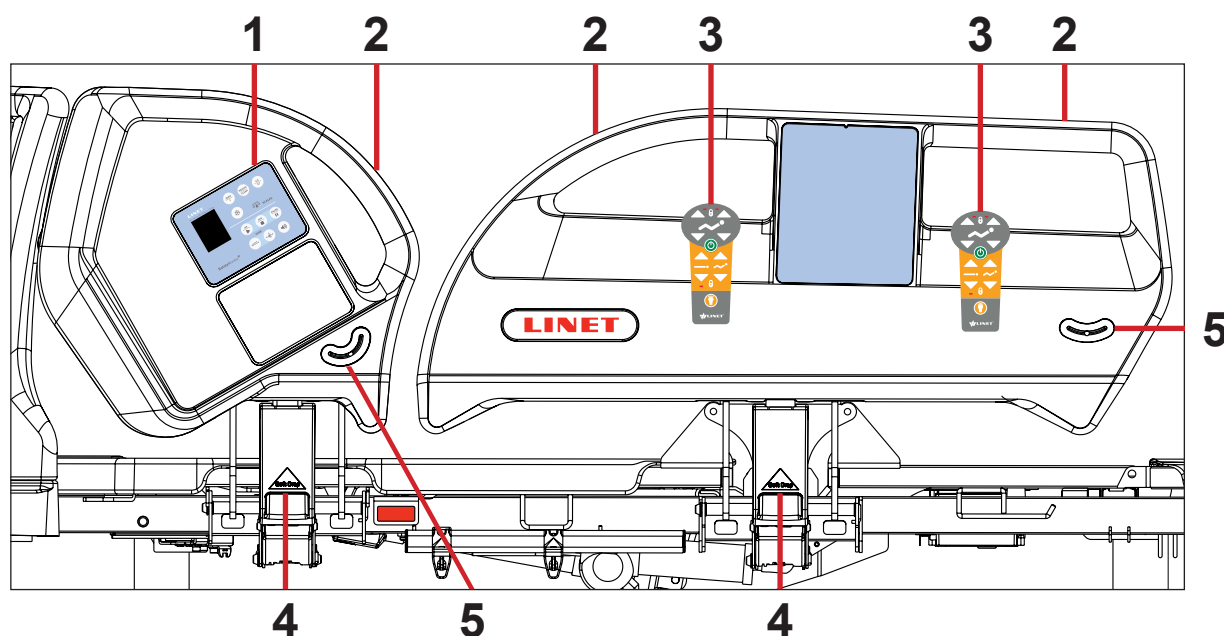

Fig. Siderails (version with iBoard Basic)

- 1. iBoard Basic
- 2. Siderail Handle
- 3. Correct Placement of Handset
- 4. Siderail Release Handle
- 5. Angle Indicator

MANIPULATION

To raise siderails up:

- ▶ Grab siderail by Siderail Handle (2).
- ▶ Pull siderail up until it latches. You will hear audible „click“.

To release siderails down:

- ▶ Grab siderail by Siderail Handle (2).
- ▶ Unlock siderail by pulling Siderail Release Handle (4) to yourself.
- ▶ Fold down siderail slowly.

SIDERAIL DESCRIPTION (version without control panels)

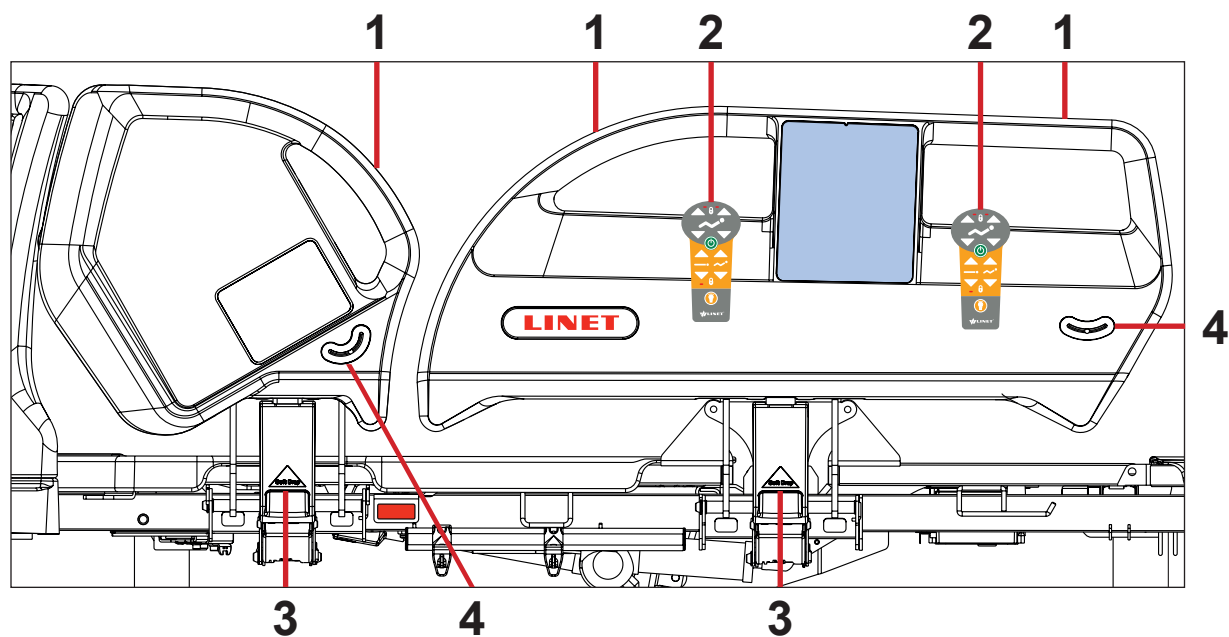

Fig. Siderails (version without control panels)

1. Siderail Handle
2. Correct Placement of Handset
3. Siderail Release Handle
4. Angle Indicator

MANIPULATION

To raise siderails up:

- ▶ Grab siderail by Siderail Handle (1).
- ▶ Pull siderail up until it latches. You will hear audible „click“.

To release siderails down:

- ▶ Grab siderail by Siderail Handle (1).
- ▶ Unlock siderail by pulling Siderail Release Handle (3) to yourself.
- ▶ Fold down siderail slowly.

11.2 Castor Control



CAUTION!

Material damage due to incorrect transport and involuntary movement!

- ▶ Prior to transport, ensure that the bed is disconnected from the mains.
- ▶ Ensure that the castors are braked prior to assembly, disassembly and maintenance.
- ▶ Ensure that the castors are braked when the bed is occupied.
- ▶ Hang the mains cable on the transport hook on the bed during transport.
- ▶ Have the bed transported exclusively by nursing personnel and by at least 2 persons.



CAUTION!

Minimal clearance underneath the bed (standard version with 15 cm castors) is 11,3 cm!

- ▶ Observe the path for any obstacles and avoid collisions and possible damages of any bed's part on the undercarriage.
- ▶ Do not use bed lifts and hoists for lifting the bed.

The bed is equipped with central castor's control and brake system.
The control levers are located in the four corners of the undercarriage.

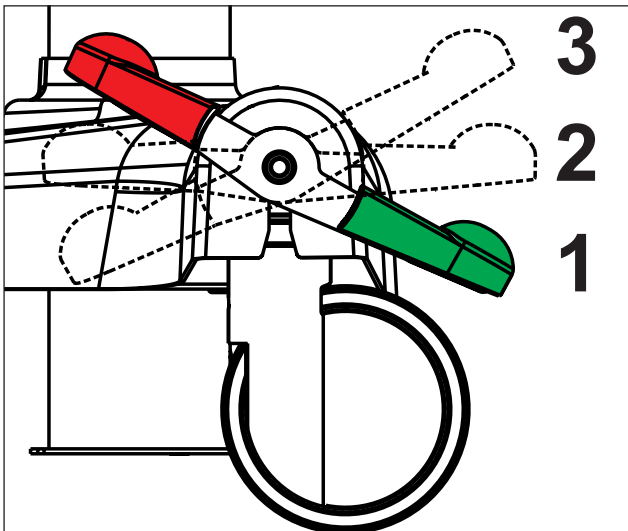

Castor control lever positions:

1. Forward Movement - Steering (GREEN PEDAL DOWN)

An arrested castor determines the direction of movement. The bed moves straight ahead. If the bed is equipped with a fifth castor, this castor determines the direction of movement.

2. Unrestricted Movement

All four castors are unlocked.

3. Braked (RED PEDAL DOWN)

All four castors are braked.

Fig. Positions of Castor Control Lever

11.3 CPR Backrest Release



WARNING!

Risk of injury due to lowering the backrest too quickly!

- ▶ Ensure that the siderails are in the low position.
- ▶ Ensure that there are no body parts between any movable parts of the bed.
- ▶ Push the Backrest down using the mattress guard handle only.

The bed allows quick, mechanical lowering of the backrest for emergency procedures (CPR).

Set the CPR position as follows:

- ▶ Pull and hold release handle.
- ▶ Push Backrest down.

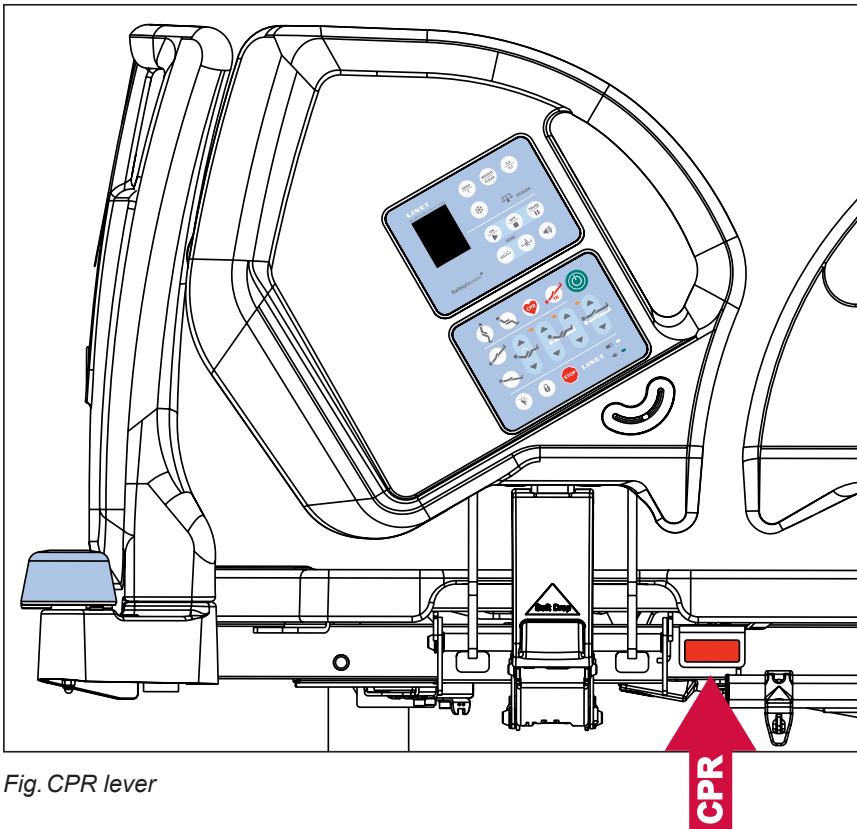

Fig. CPR lever

11.4 Control Elements

The bed is operated by different control elements.

Control elements depending on the model:

- Nurse Control Panel in both head siderails
- iBoard Basic in both head siderails
- Attendant Control Panel
- Handset with illuminated buttons and with adapter for easy connection (Plug and Play)
- Patient Control Panel in both foot siderails
- Foot Switch - Bed Height

Disabling individual functions on the Attendant Control Panel or on the Nurse Control Panel will affect all control elements.

If the bed does not react to individual position settings:

- ▶ Check whether the function is disabled on the Attendant Control Panel or on the Nurse Control Panel.

POSITIONING	Nurse Control Panel	Attendant Control Panel	Handset	Patient Control Panel	Foot Switch- Bed Height
Backrest	✓	✓	✓	✓	
Thighrest	✓	✓	✓	✓	
Bed Height	✓	✓	✓		✓
Autocontour	✓	✓	✓	✓	
Examination Position		✓			✓
Emergency Trendelenburg Position	✓	✓			
Anti-Trendelenburg and Trendelenburg Tilt	✓	✓			
CPR Position	✓	✓			
Cardiac Chair Position	✓	✓			
Mobilization Position	✓				

11.4.1 Nurse Control Panel (optional)

The Nurse Control Panel is the main Control Element for the caregivers. It is integrated in the outside of both head siderails.

- ▶ Ensure that exclusively trained nursing staff operates the Nurse Control Panel.

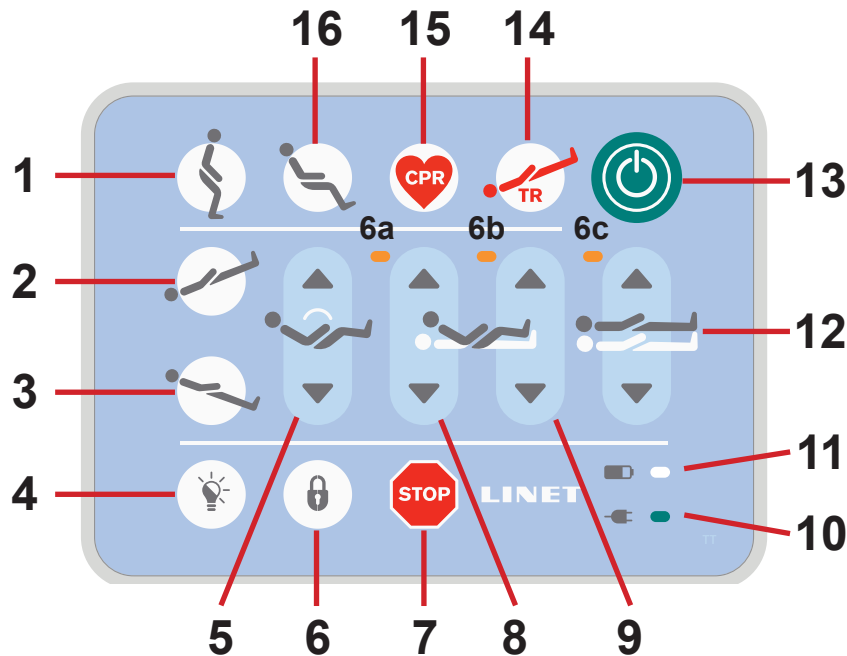



Fig. Nurse Control Panel

1. Mobilization Position Button
2. Trendelenburg Tilt Button
3. Anti-Trendelenburg Tilt Button
4. LIGHT CONTROL Button
5. Autocontour Adjustment Buttons (simultaneous movement of the Backrest and Thighrest)
6. LOCK Button
- 6a. Locked Backrest LED
- 6b. Locked Thighrest LED
- 6c. Locked Bed Height, Trendelenburg Tilt and Anti-Trendelenburg Tilt LED
7. Central STOP Button
8. Backrest Adjustment Buttons
9. Thighrest Adjustment Buttons
10. Mains Power LED
11. Accumulator LED
12. Bed Height Adjustment Buttons
13. GO Button
14. Emergency Trendelenburg Position Button
15. CPR (Resuscitation) Position Button
16. Cardiac Chair Position Button

Positioning buttons 1, 2, 3, 5, 8, 9, 12, 14, 15 and 16 are explained in chapter **Bed Positioning**.

GO BUTTON

The button  activates the keyboard of all Control Elements.

Pressing button  will keep the keyboard active for 3 minutes.

Pressing a button will keep the keyboard active for another 3 minutes.

During this time the following is possible:

- ▶ Adjusting individual Mattress support platform elements by pressing the corresponding positioning buttons.
- ▶ Disabling individual functions with the lock buttons.

NOTE: To activate CPR function (button ) the button  is not needed.

STOP BUTTON

Pressing button  immediately stops all electronic bed movements.

LOCK

To lock Backrest Adjustment:

▶ Press button .

LED Lock **6a**, **6b** and **6c** are flashing.

▶ During flashing of the LEDs press any button **8**.

LED Lock **6a** is lit.

Backrest Adjustment is disabled using any Control Element.

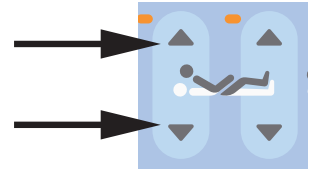

To lock Thighrest:

▶ Press button .

LED Lock **6a**, **6b** et **6c** are flashing.

▶ During flashing of the LEDs press any button **9**.

LED Lock **6b** is lit.

Thighrest is disabled using any Control Element.

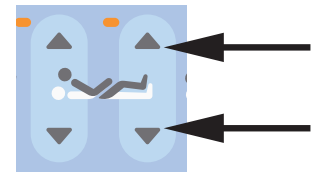

To lock Bed Height, Trendelenburg Tilt and Anti-Trendelenburg Tilt :

▶ Press button .

LED Lock **6a**, **6b** et **6c** are flashing.

▶ During flashing of the LEDs press any button **12**.

LED Lock **6c** is lit.

Bed Height, Trendelenburg Tilt and Anti-Trendelenburg Tilt are disabled using any Control Element.

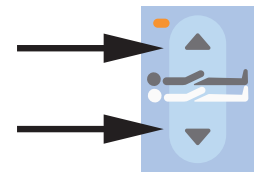

UNLOCK

To unlock Backrest Adjustment:

▶ Press button .

LED Lock **6a**, **6b** et **6c** are flashing.

▶ During flashing of the LEDs press any button **8**.

LED Lock **6a** is unlit.

Backrest Adjustment is enabled again.

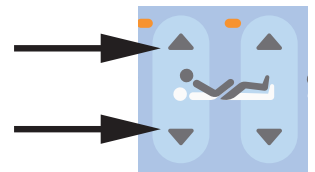

To unlock Thighrest:

▶ Press button .

LED Lock **6a**, **6b** et **6c** are flashing.

▶ During flashing of the LEDs press any button **9**.

LED Lock **6b** is unlit.

Thighrest is enabled again.

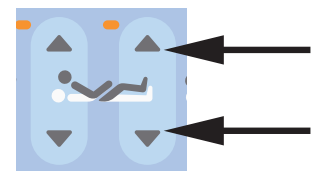

To unlock Bed Height, Trendelenburg Tilt and Anti-Trendelenburg Tilt:

- ▶ Press button  .

LED Lock **6a**, **6b** et **6c** are flashing.

- ▶ During flashing of the LEDs press any button **12**.

LED Lock **6c** is unlit.

Bed Height, Trendelenburg Tilt and Anti-Trendelenburg Tilt are enabled again.

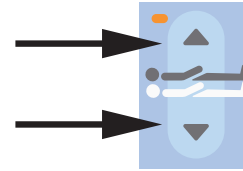

LOCKED FUNCTION SIGNALISATION

If LED **6a** is lit, Backrest Adjustment is locked.

If LED **6a** is not lit, Backrest Adjustment is unlocked.

If LED **6b** is lit, Thighrest is locked.

If LED **6b** is not lit, Thighrest is unlocked.

If LED **6c** is lit, Bed Height and Trendelenburg Tilt and Anti-Trendelenburg Tilt are locked.

If LED **6c** is not lit, Bed Height and Trendelenburg Tilt and Anti-Trendelenburg Tilt are unlocked.

ACCUMULATOR INDICATOR

Signalisation of Accumulator LED  is described in chapter **Accumulator**.

MAINS POWER LED

Status	Meaning
lit LED	connected to the mains
unlit LED	disconnected from the mains
flashing LED	system error

LIGHT CONTROL BUTTON

To turn off lights of the control elements:

- ▶ Press button  .

To turn on lights of the control elements again:

- ▶ Press button  .

11.4.2 iBoard Basic (standard)

The iBoard Basic is the standard control element for the caregivers. It is integrated in the outside of both head siderails. Only bed version with scales can be equipped with iBoard Basic. The iBoard Basic serves for control of scales and control of Bed Exit Monitoring.

- ▶ Ensure that exclusively trained nursing staff operates the iBoard Basic.

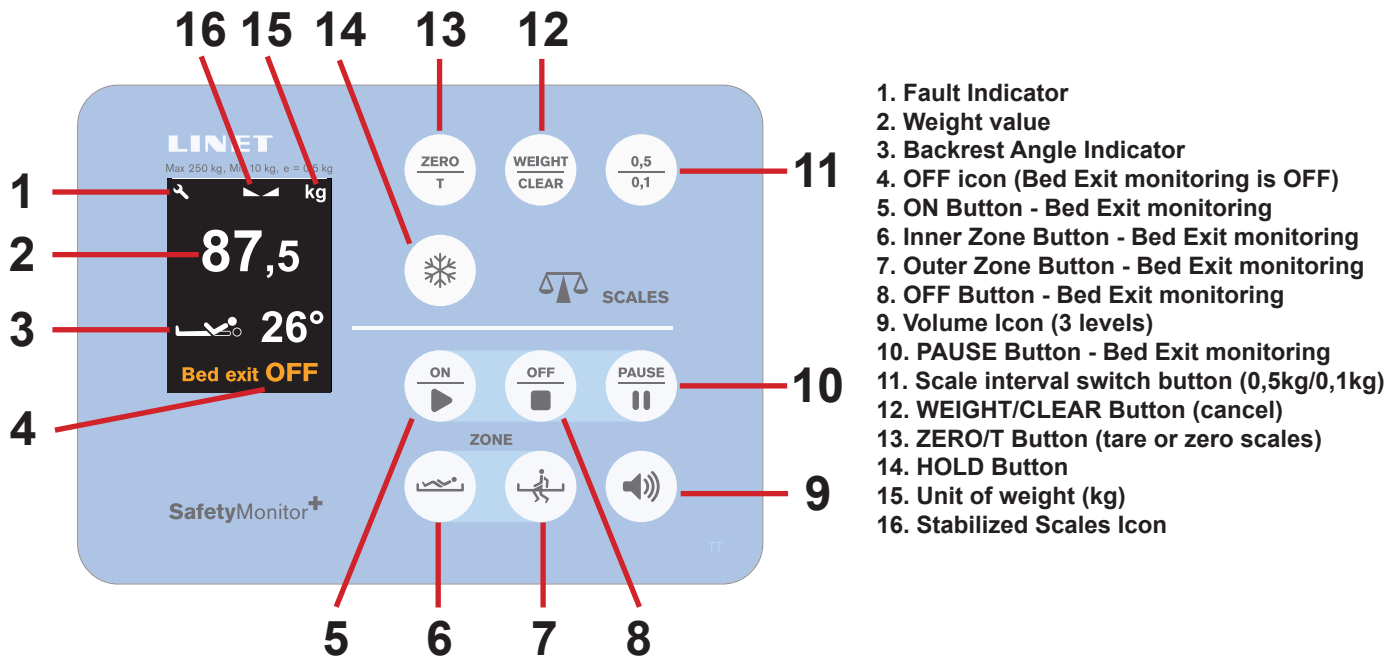

Fig. iBoard Basic













Scales Section (only version with scales)

Eleganza 4 is optionally equipped with a weighing system that allows weighing the patient in bed. There are control buttons and display for the weighing system on the Scales section of iBoard Basic. Scales functions are described in chapter **Scales Control**.

Bed Exit Monitoring Section (only version with scales)

Eleganza 4 is optionally equipped with a Bed Exit Monitoring system that monitors patient's presence in bed and triggers alarms when patient is not present in bed. There are control buttons and display for the Bed Exit Monitoring on the SafetyMonitor section of iBoard Basic. Functions of Bed Exit Monitoring are described in chapter **Bed Exit Monitoring**.

Statuses (iBoard Basic)

Signalisation	Meaning	Required Action
	Function locked.	Unlock function if required!
	GO Button not activated.	Press GO Button!
0°	Optionally: Horizontal position was reached during tilting.	Press corresponding button to continue in positioning.
OVERLOAD + 	Safe Working Load exceeded (more than 10 kg over Safe Working Load).	Remove load!
STOP SERVICE +  + 	System Fatal Error.	Contact service department approved by manufacturer.
SCALE / BEA DISCONNECTED +  + 	Scale module disconnected and Bed Exit monitoring disabled.	Contact service department approved by manufacturer.
SAFE STOP + 	Movement of the Mattress support platform stopped by function Safestop.	Remove an object from undercarriage to continue in adjusting the bed height.
	Insufficient load for Bed Exit monitoring.	Place patient on the bed to enable the Bed Exit monitoring.
	Disconnected from the mains power supply.	Connect bed to the mains power.
BED EXIT +  ALARM + 	The patient has left the bed (Outer Zone monitoring) or the patient has left the Inner Zone (Inner Zone monitoring).	Check the patient and turn off the Bed Exit Alarm.
HIGH	Safe Working Load exceeded (from 4,5 kg to 10 kg over Safe Working Load).	Remove load!
LOW	The bed is underloaded.	Ensure the mattress support platform is not lifted inconveniently by something and the scales are appropriately tared.

11.4.3 Attendant Control Panel

The Attendant Control Panel is a standard control element. The Attendant Control Panel can be hung on the foot board or on the siderails if required. The Attendant Control Panel can be stored in the Linen Shelf. It is possible to hold the Attendant Control Panel in the hand while operating.

- ▶ Ensure that exclusively trained nursing staff operates the Attendant Control Panel.

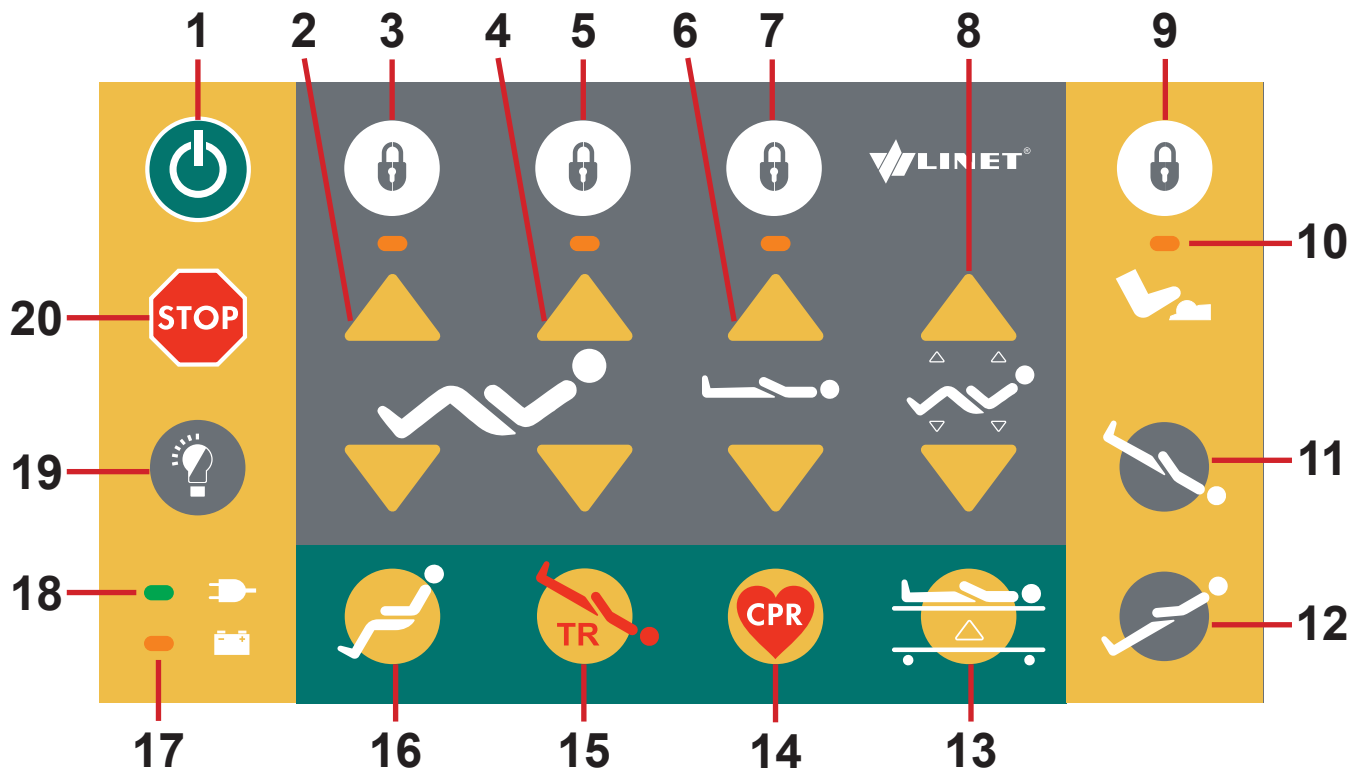

Fig. Attendant Control Panel

1. GO Button
2. Thighrest Adjustment Button
3. Thighrest Adjustment Lock Button and LED
4. Backrest Adjustment Button
5. Backrest Lock Button and LED
6. Bed Height Adjustment Button
7. Bed Height, Trendelenburg Tilt and Anti-Trendelenburg Tilt Lock Button and LED
8. Autocontour Adjustment Button
9. Foot Switch Lock Button
10. Foot Switch Lock LED
11. Trendelenburg Tilt Button
12. Anti-Trendelenburg Tilt Button
13. Examination Position Button
14. CPR Position Button
15. Emergency Trendelenburg Position Button
16. Cardiac Chair Position Button
17. Accumulator Charge Status LED
18. Mains Power LED
19. LIGHT CONTROL Button
20. STOP Button

Central STOP Button

The central STOP Button immediately interrupts all bed movements in case of unauthorized bed positioning or an electronic failure. Pressing the central STOP Button for at least 0.3 seconds immediately stops all electronic bed movements.

Activating GO Button



The GO Button activates the keypad of all control elements for 3 minutes. A GO Button is included on a number of different control elements. The function of the GO Button is identical on all control elements.

During this time the following is possible:

- ▶ Adjusting individual mattress support platform elements by pressing the corresponding function buttons.
- ▶ Disabling individual functions with the lock buttons.

Each time a function button is pressed, the keypad will remain active for another 3 minutes.

Function Buttons

The function buttons **2, 4, 6, 8, 11, 12, 13, 14, 15** and **16** are described in chapter **Bed Positioning**.

NOTE Pressing two function buttons at the same time will be recognized as an error by the controller. The controller will interrupt immediately all bed movements and display shows adequate pop up.

Lock

To lock Backrest Adjustment:

- ▶ Press button **5**.

Corresponding LED on Attendant Control Panel and on Nurse Control Panel (**6a**) are lit.

Backrest Adjustment is disabled using any Control Element.

To lock Thighrest Adjustment:

- ▶ Press button **3**.

Corresponding LED on Attendant Control Panel and on Nurse Control Panel (**6b**) are lit.

Thighrest Adjustment is disabled using any Control Element.

To lock Bed Height, Trendelenburg Tilt and Anti-Trendelenburg Tilt Adjustment:

- ▶ Press button **7**.

Corresponding LED on Attendant Control Panel and on Nurse Control Panel (**6c**) are lit.

Bed Height, Trendelenburg Tilt and Anti-Trendelenburg Tilt Adjustment are disabled using any Control Element.

To lock Foot Switches:

- ▶ Press button **9**.

Corresponding LED (**10**) on Attendant Control Panel is lit.

Bed Height and Examination Position are disabled using Foot Switches.

Unlock

To unlock Backrest Adjustment:

- ▶ Press button **5**.

Corresponding LED on Attendant Control Panel and on Nurse Control Panel (**6a**) are not lit.

Backrest Adjustment is enabled again.

To unlock Thighrest Adjustment:

- ▶ Press button **3**.

Corresponding LED on Attendant Control Panel and on Nurse Control Panel (**6b**) are not lit.

Thighrest Adjustment is enabled again.

To unlock Bed Height, Trendelenburg Tilt and Anti-Trendelenburg Tilt Adjustment:

- ▶ Press button **7**.

Corresponding LED on Attendant Control Panel and on Nurse Control Panel (**6c**) are not lit.

Bed Height, Trendelenburg Tilt and Anti-Trendelenburg Tilt Adjustment are enabled again.

To unlock Foot Switches:

- ▶ Press button **9**.

Corresponding LED (**10**) on Attendant Control Panel is no lit.

Bed Height and Examination Position are enabled again.

MAINS POWER LED 

Status	Meaning
lit LED	connected to the mains
unlit LED	disconnected from the mains
flashing LED	system error

11.4.4 Handset (optional)

The handset is available with illuminated keyboard.

NOTE The illumination is activated for 7s if any button was pressed and the illumination is activated for 3 minutes if GO Button was pressed.

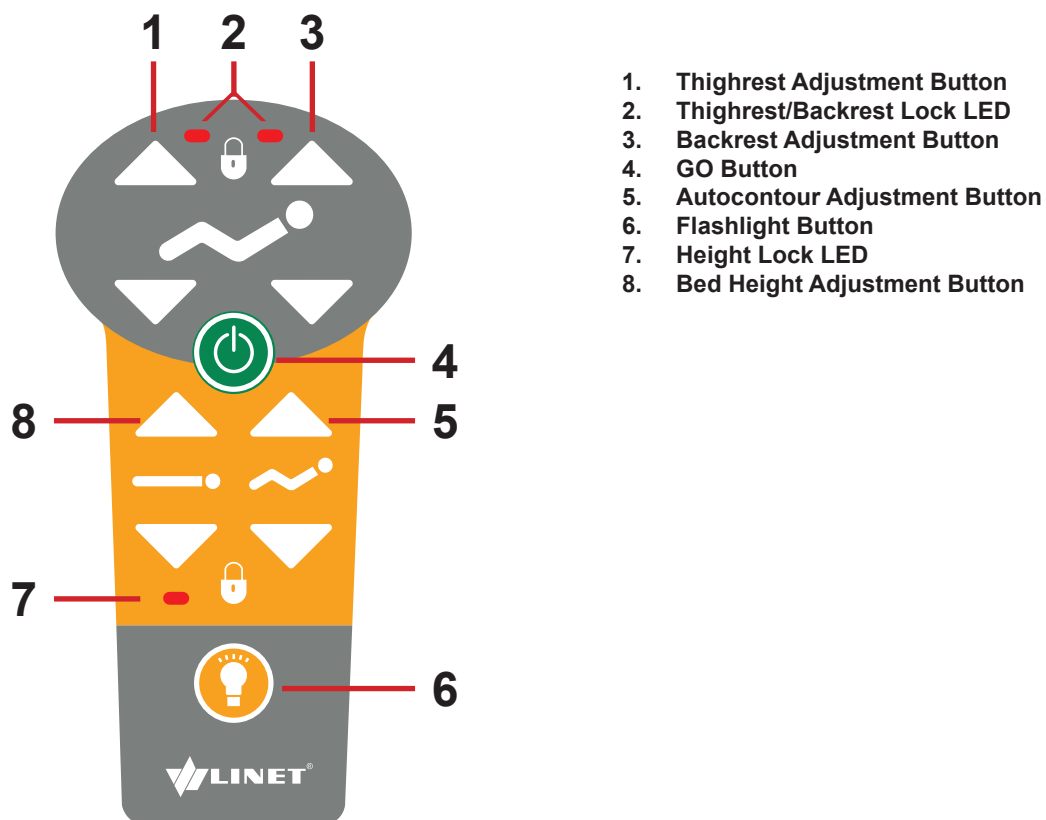

- 1. Thighrest Adjustment Button
- 2. Thighrest/Backrest Lock LED
- 3. Backrest Adjustment Button
- 4. GO Button
- 5. Autocontour Adjustment Button
- 6. Flashlight Button
- 7. Height Lock LED
- 8. Bed Height Adjustment Button

Fig. Handset

The function buttons 1, 3, 5 and 8 are described in chapter **Bed Positioning**.

To switch on the flashlight:

- ▶ Press flashlight button 6.

NOTE Depending on the patient's condition, the nursing staff decides whether the patient is allowed to adjust the bed's position.

If required, prevent the patient from adjusting the bed as follows:

- ▶ Disable functions.

NOTE An adapter for the handset is available. The adapter enables quick installation and removal (e.g. replacing a defective handset, using the handset for another bed).

11.4.5 Foot Switch - Bed Height (optional)

The foot control is optional and allows setting the Height of the bed or Examination Position with one's feet. Press the selected pedal twice in 3 seconds. Bed Height Foot Control is activated for 20s after this procedure.

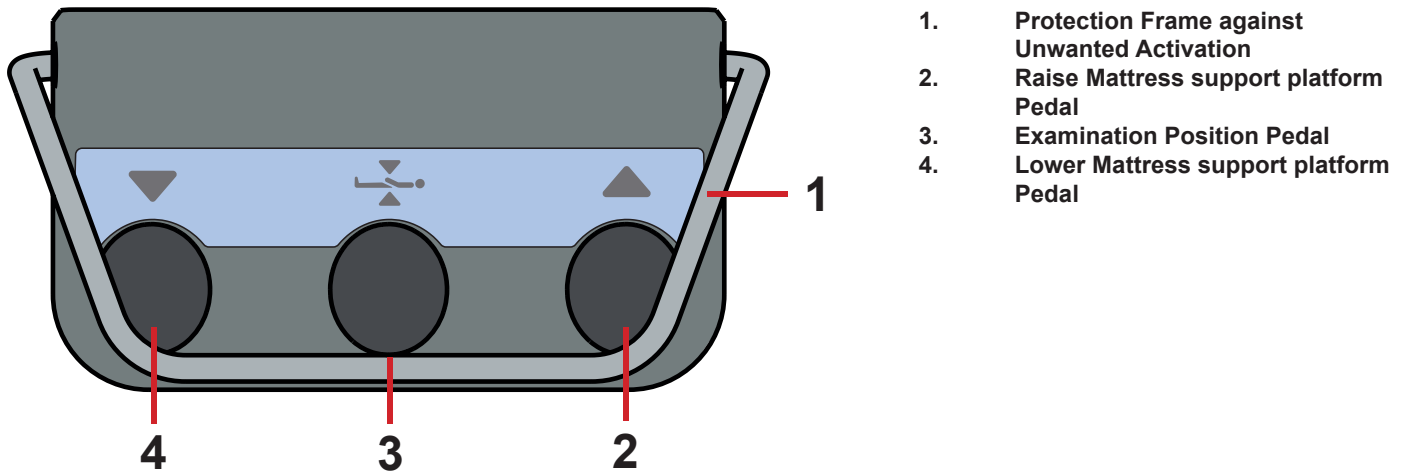

Fig. Foot Switch - Bed Height

The use of Foot Switch - Bed Height is described in the chapter **Bed Positioning**.

11.4.6 Patient Control Panels

The patient control panels integrated in the foot siderails allow the patient to adjust the positions of the Backrest, Thighrest and Autocontour.

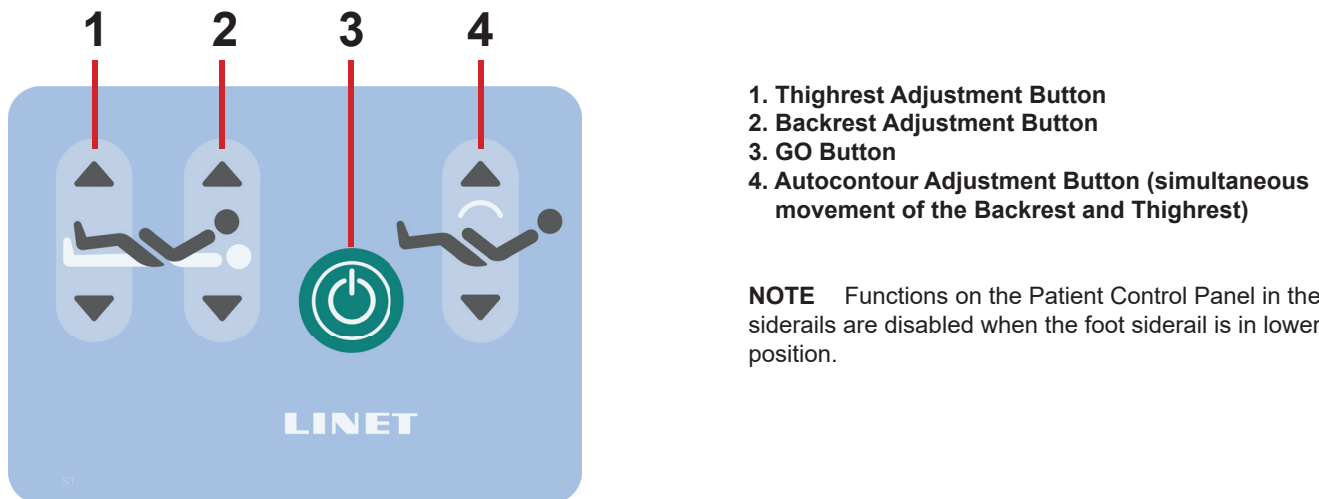
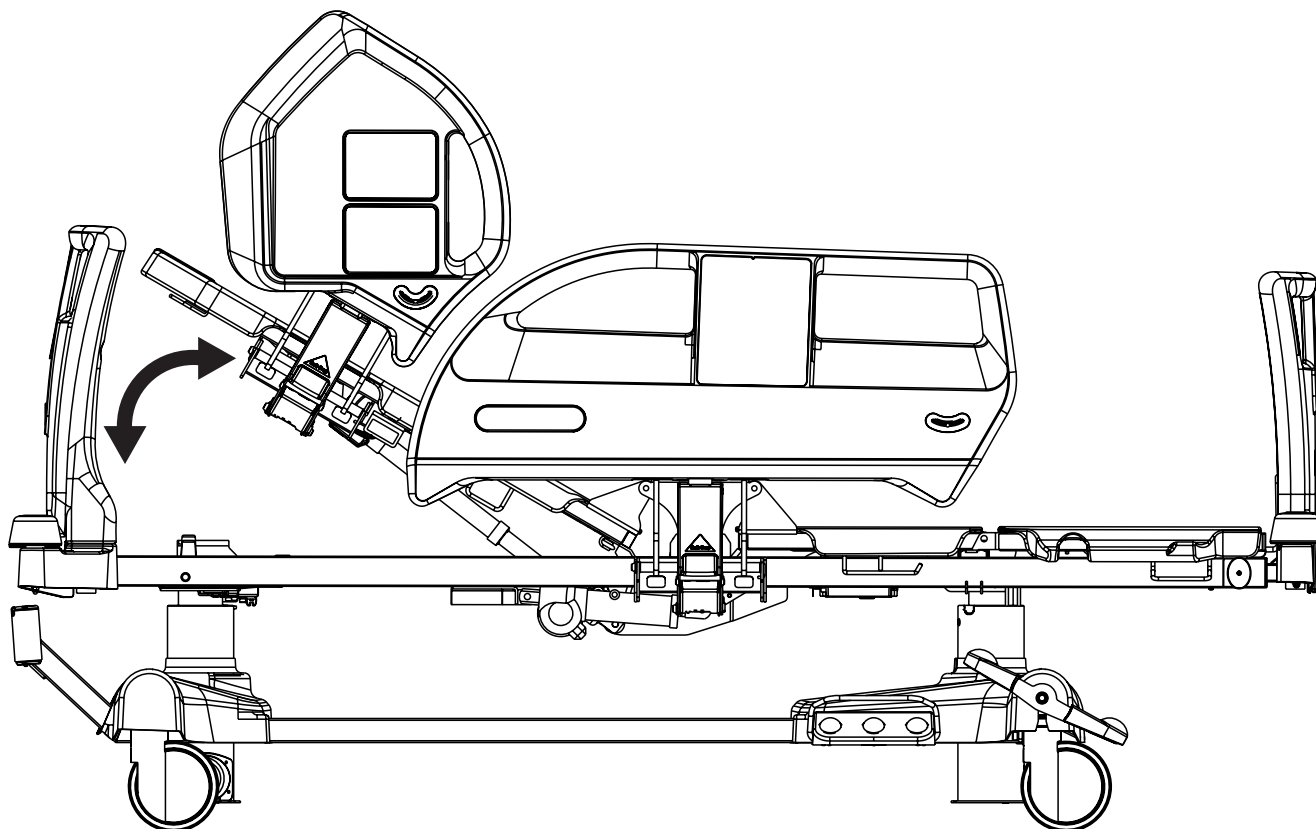

Fig. Patient Control Panel in the foot siderails

NOTE Functions on the Patient Control Panel in the foot siderails are disabled when the foot siderail is in lower position.

11.5 Bed Positioning

11.5.1 Backrest



To position Backrest use:

- ▶ Nurse Control Panel
- ▶ Attendant Control Panel
- ▶ Handset
- ▶ Patient Control Panel



Fig. Backrest Angle on iBoard Basic Display

iBoard Basic Display shows Backrest Angle.

During continuous positioning Backrest stops automatically in 30 and 45 degrees. To continue in positioning release the button, then press and hold button until the desired position is reached.

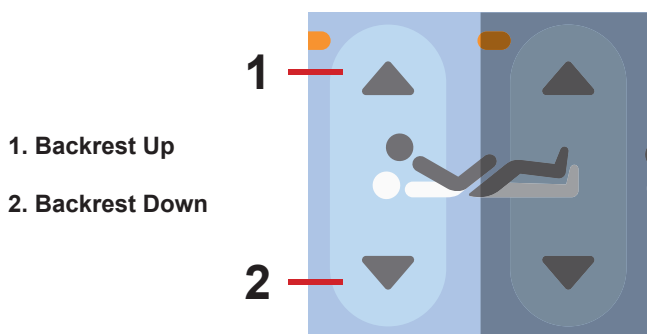



Fig. Backrest Adjustment Button (Nurse Control Panel, Patient Control Panel)

Nurse Control Panel:

- ▶ Press button  .
- ▶ Press selected part of Backrest Adjustment Button until intended position is reached.

Patient Control Panel:

- ▶ Press button  .
- ▶ Press selected part of Backrest Adjustment Button until intended position is reached.

- 1. Backrest Up
- 2. Backrest Down

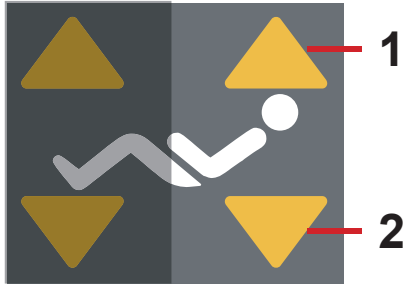



Fig. Backrest Adjustment Button (Attendant Control Panel)

Attendant Control Panel:

- ▶ Press button .
- ▶ Press selected part of Backrest Adjustment Button until intended position is reached.

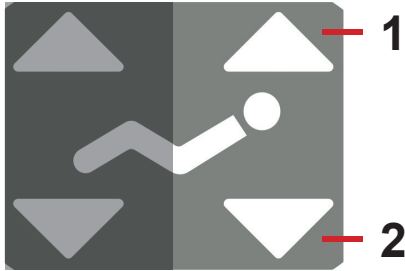

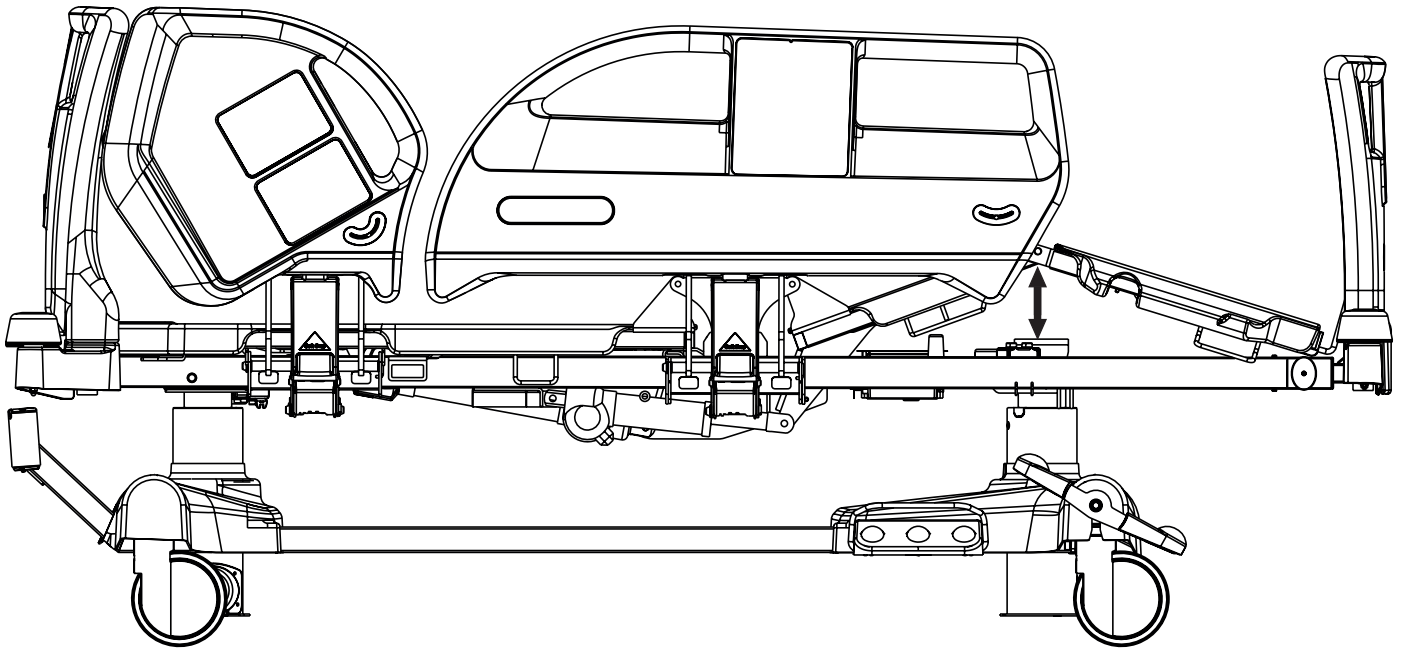

Fig. Backrest Adjustment Button (Handset)

Handset:

- ▶ Press button .
- ▶ Press selected part of Backrest Adjustment Button until intended position is reached.

11.5.2 Thighrest



To position Thighrest use:

- ▶ Nurse Control Panel
- ▶ Attendant Control Panel
- ▶ Handset
- ▶ Patient Control Panel

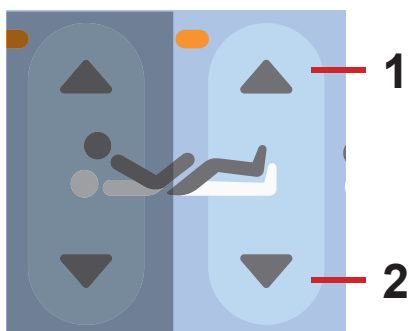

Fig. Thighrest Adjustment Button (Nurse Control Panel, Patient Control Panel)

Nurse Control Panel:

- ▶ Press button .
- ▶ Press selected part of Thighrest Adjustment Button until intended position is reached.

Patient Control Panel:

- ▶ Press button .
- ▶ Press selected part of Thighrest Adjustment Button until intended position is reached.

1. Thighrest Up

2. Thighrest Down



Fig. Thighrest Adjustment Button (Attendant Control Panel)

Attendant Control Panel:

- ▶ Press button .
- ▶ Press selected part of Thighrest Adjustment Button until intended position is reached.

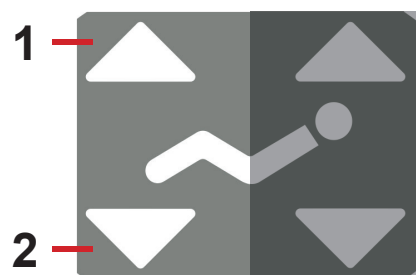
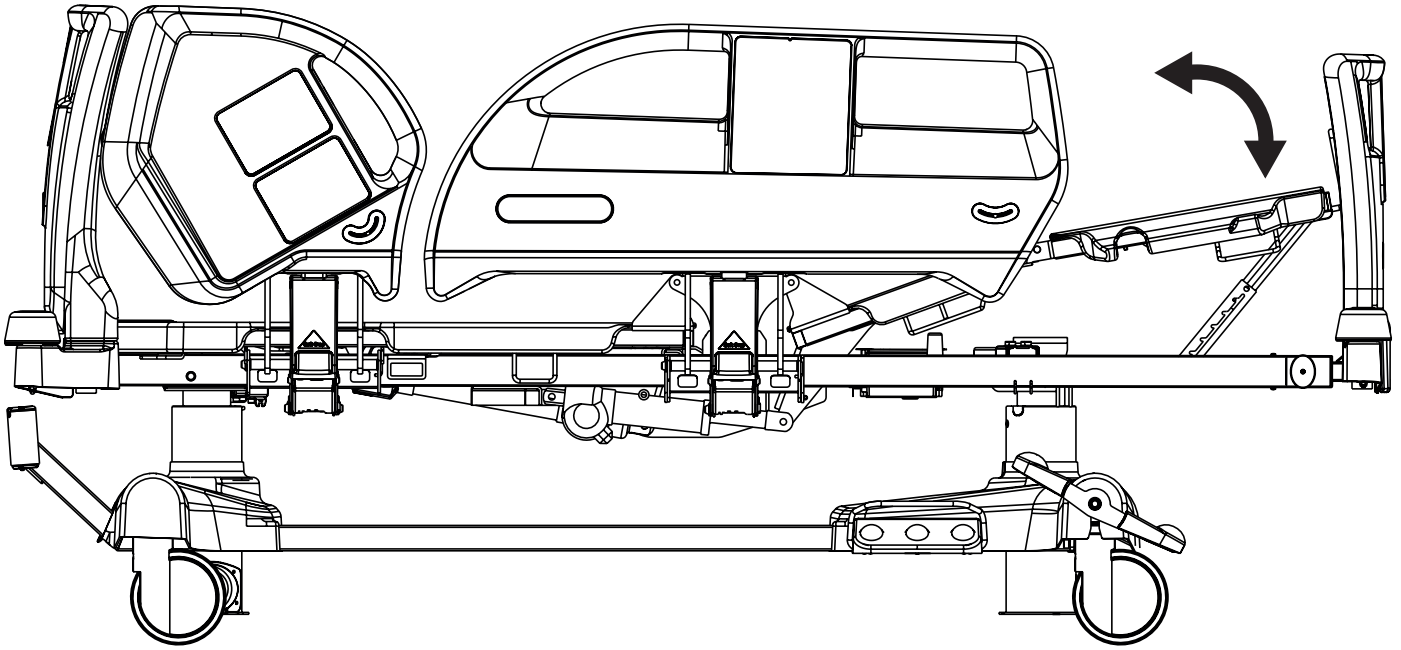

Fig. Thighrest Adjustment Button (Handset)

Handset:

- ▶ Press button .
- ▶ Press selected part of Thighrest Adjustment Button until intended position is reached.

11.5.3 Mechanical Calfrest Adjustment



WARNING!

Incorrect manipulation can injure the patient or the user!

- ▶ Hold the Calfrest by both Calfrest Handles at all times when lowering the Calfrest.
- ▶ Lower the Calfrest carefully to prevent it from falling suddenly.

To raise the Calfrest:

- ▶ lift Calfrest by the handle to intended position.
- ▶ lower the Calfrest so that catch fits in the ratchet-bar.

To lower the Calfrest:

- ▶ lift Calfrest slightly by the handle.
- ▶ lower Calfrest to intended position.
- ▶ ensure the catch fits in the ratchet-bar.

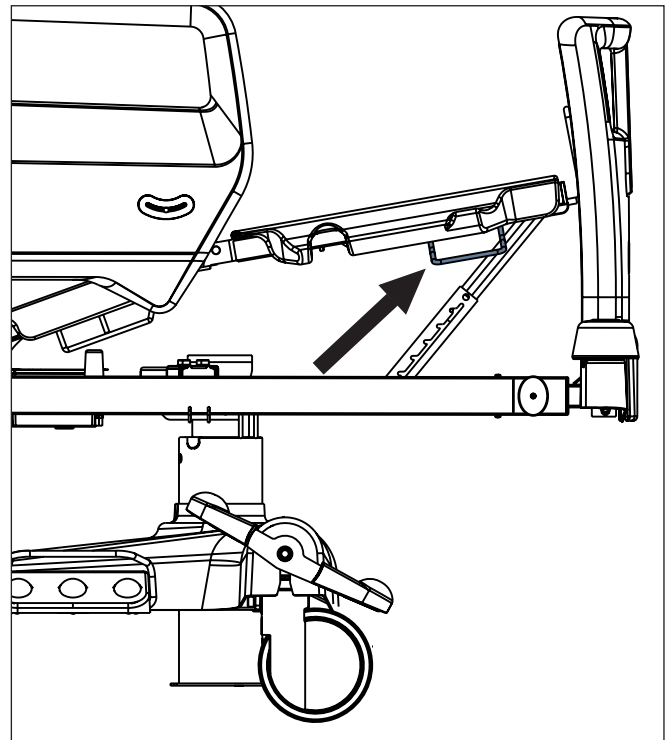
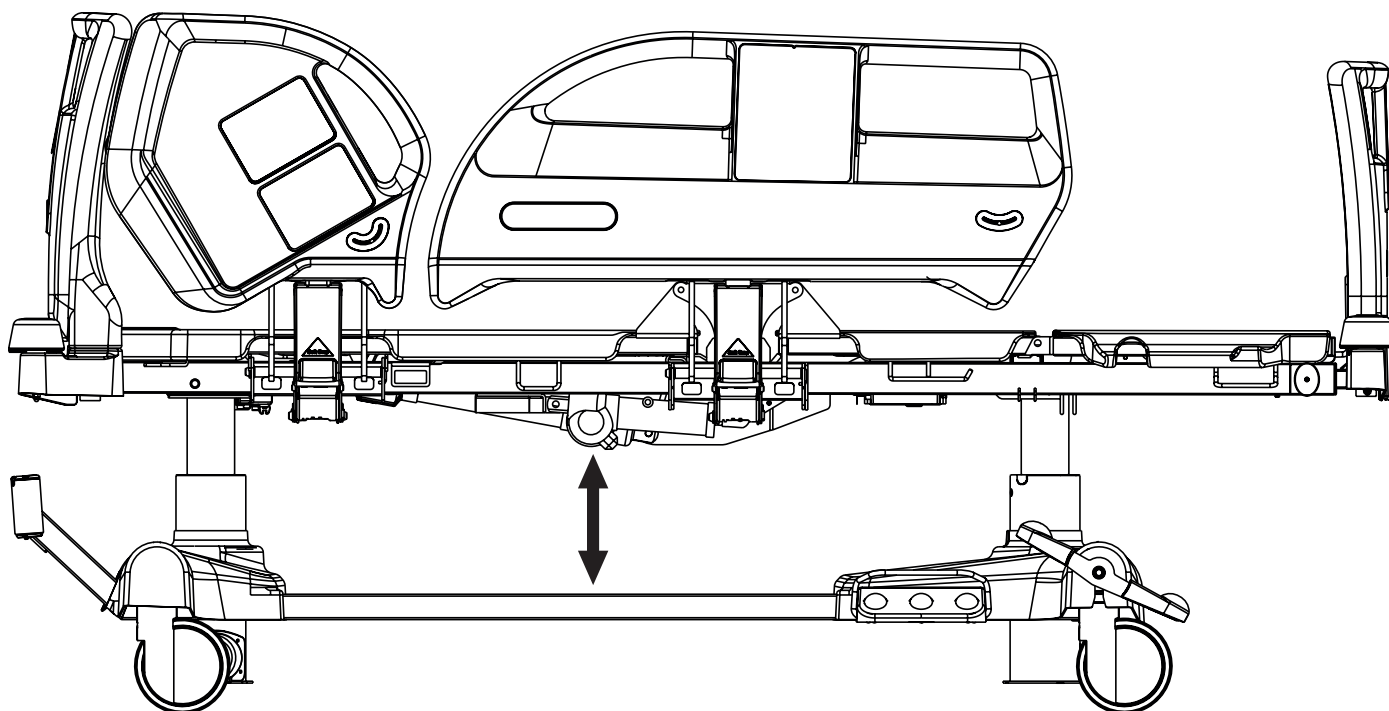

Fig. Position of Calfrest Handle

11.5.4 Bed Height



To position Bed Height use:

- ▶ Nurse Control Panel
- ▶ Attendant Control Panel
- ▶ Handset
- ▶ Foot Switch - Bed Height
- ▶ Mobi-Lift Handle

The bed stops in the low position during lowering, mattress support platform is adjusted to flat position and beep is performed. After this adjustment the lowering continues to the lowest position.

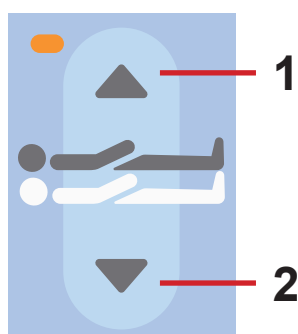

Fig. Bed Height Adjustment Button (Nurse Control Panel)

Nurse Control Panel:

- ▶ Press button .
- ▶ Press selected part of Bed Height Adjustment Button until intended position is reached.

1. Mattress support platform Up
2. Mattress support platform Down

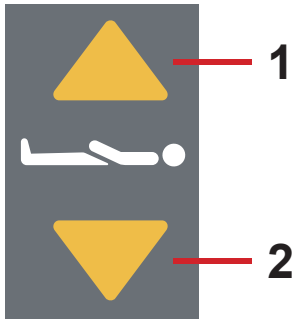

Fig. Bed Height Adjustment Button (Attendant Control Panel)

Attendant Control Panel:

- ▶ Press button .
- ▶ Press selected part of Bed Height Adjustment Button until intended position is reached.

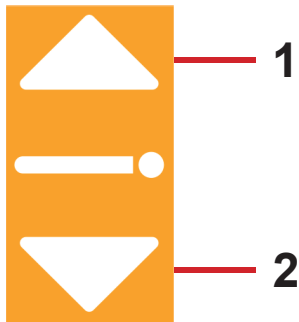



Fig. Bed Height Adjustment Button (Handset)

Handset:

- ▶ Press button .
- ▶ Press selected part of Bed Height Adjustment Button until intended position is reached.

1. Mattress support platform Up
2. Mattress support platform Down



Fig. Bed Height Adjustment Pedals (Foot Switch - Bed Height)

Foot Switch - Bed Height:

- ▶ Press and release the selected Bed Height Adjustment Pedal to activate the panel.
- ▶ Press and hold selected Bed Height Adjustment Pedal until intended position is reached.

NOTE Press the selected pedal twice in 3 seconds. Bed Height Foot Control is activated for 20s after this procedure.

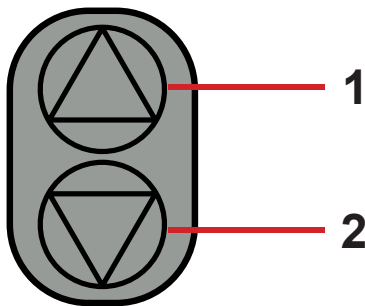

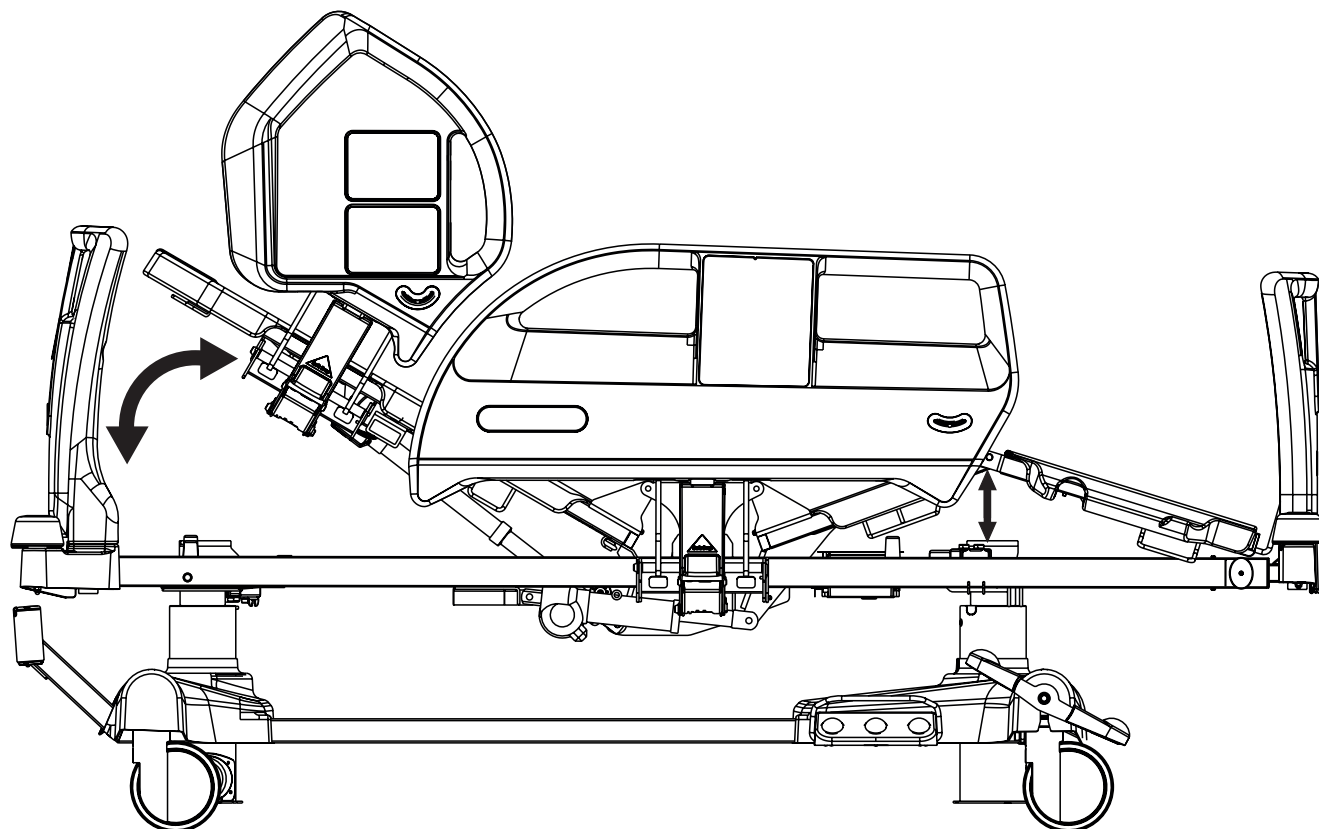

Fig. Mobi-Lift Bed Height Button

Mobi-Lift:

- ▶ Press button .
- ▶ Press selected part of Mobi-Lift Bed Height Button until intended position is reached.

11.5.5 Autocontour



To position Autocontour use:

- ▶ Nurse Control Panel
- ▶ Attendant Control Panel
- ▶ Handset
- ▶ Patient Control Panel

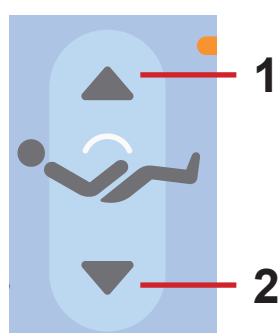



Fig. Autocontour Adjustment Button
(Nurse Control Panel, Patient Control Panel)

Nurse Control Panel:

- ▶ Press button  .
- ▶ Press selected part of Autocontour Adjustment Button until intended position is reached.

Patient Control Panel:

- ▶ Press button  .
- ▶ Press selected part of Autocontour Adjustment Button until intended position is reached.

1. Autocontour Up

2. Autocontour Down

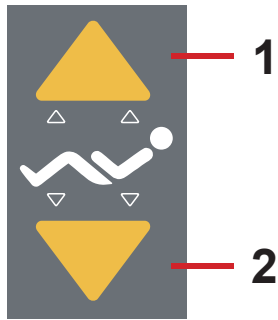



Fig. Autocontour Adjustment Button (Attendant Control Panel)

Attendant Control Panel:

- ▶ Press button .
- ▶ Press selected part of Autocontour Adjustment Button until intended position is reached.

1. Autocontour Up

2. Autocontour Down

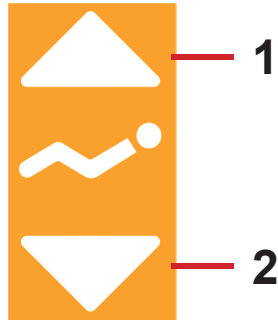

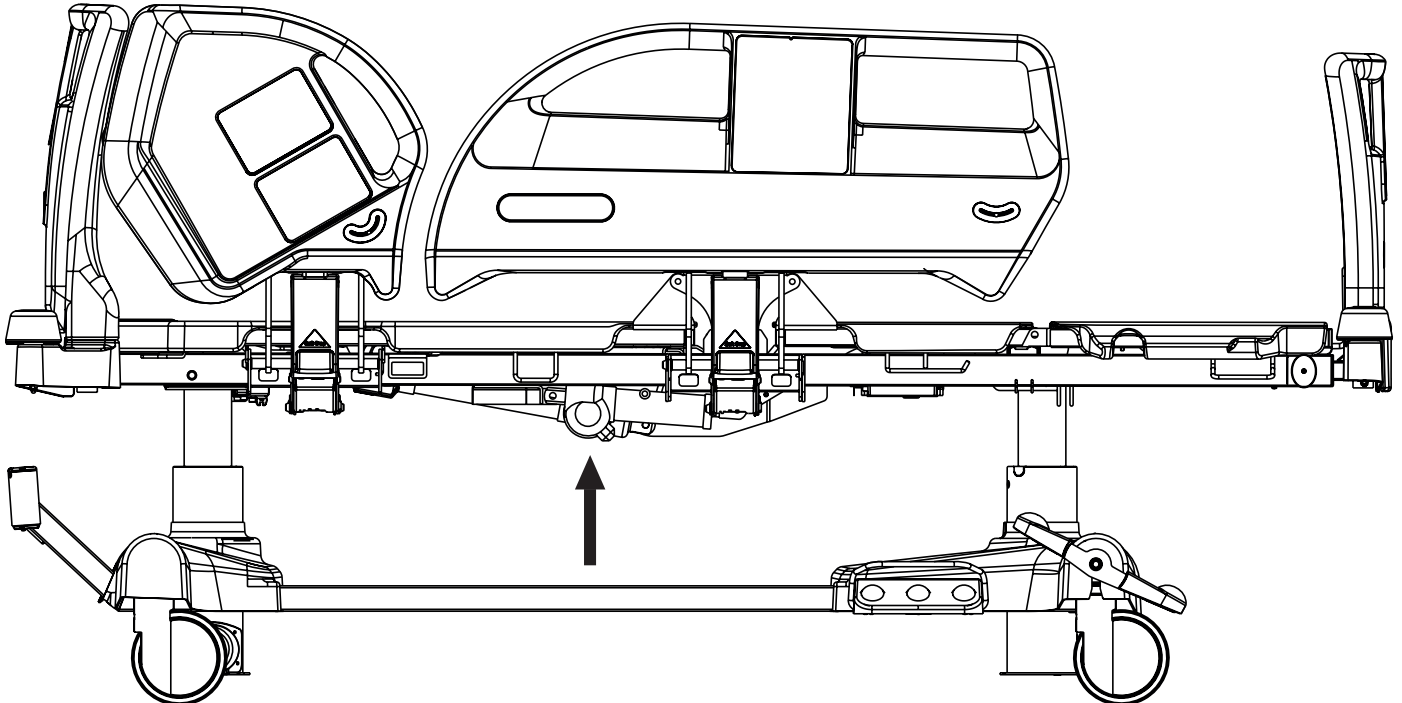

Fig. Autocontour Adjustment Button (Handset)

Handset:

- ▶ Press button .
- ▶ Press selected part of Autocontour Adjustment Button until intended position is reached.

11.5.6 Examination Position



To position Examination Position use:

- ▶ Attendant Control Panel
- ▶ Foot Switch - Bed Height



Fig. Examination Position Button (Attendant Control Panel)

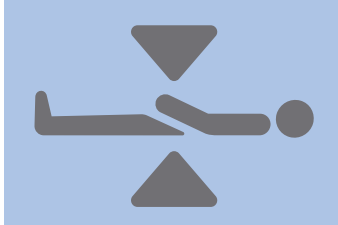

Fig. Examination Position Pedal (Foot Switch - Bed Height)

Attendant Control Panel:

- ▶ Press button  .
- ▶ Press Examination Position Button until intended position is reached.

Foot Switch - Bed Height:

- ▶ Press and release the middle pedal to activate the panel.
- ▶ Press and hold Examination Position Pedal until intended position is reached.

NOTE There must be less than 20 seconds between these 2 steps.

11.5.7 Emergency Trendelenburg Position

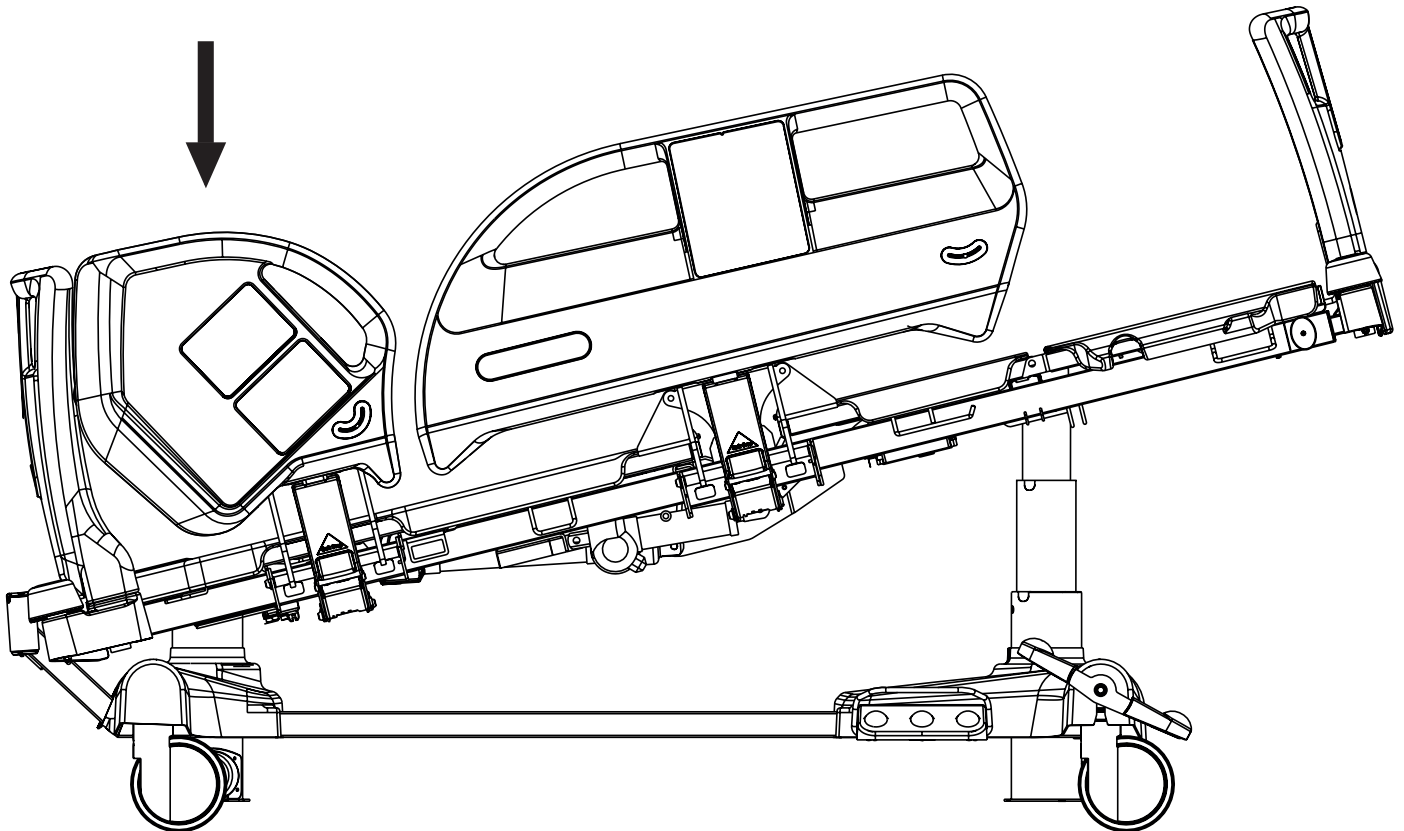

Fig. Emergency Trendelenburg Position/Trendelenburg Tilt

To position Emergency Trendelenburg Position use:

- ▶ Nurse Control Panel
- ▶ Attendant Control Panel

Trendelenburg position provides anti-shock conditions for the patient.
During Trendelenburg Position Mattress support platform is straightened in the tilt.
The LOCK function does not influence the Emergency Trendelenburg Position function!

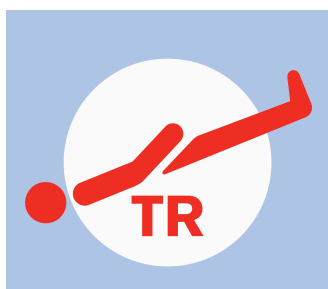

Fig. Emergency Trendelenburg Position Button (Nurse Control Panel)

Nurse Control Panel:

- ▶ Press button .
- ▶ Press Emergency Trendelenburg Position Button until intended position is reached.

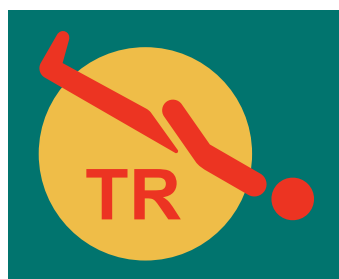

Fig. Emergency Trendelenburg Position Button (Attendant Control Panel)

Attendant Control Panel:

- ▶ Press button .
- ▶ Press Emergency Trendelenburg Position Button until intended position is reached.

11.5.8 Anti-Trendelenburg Tilt and Trendelenburg Tilt

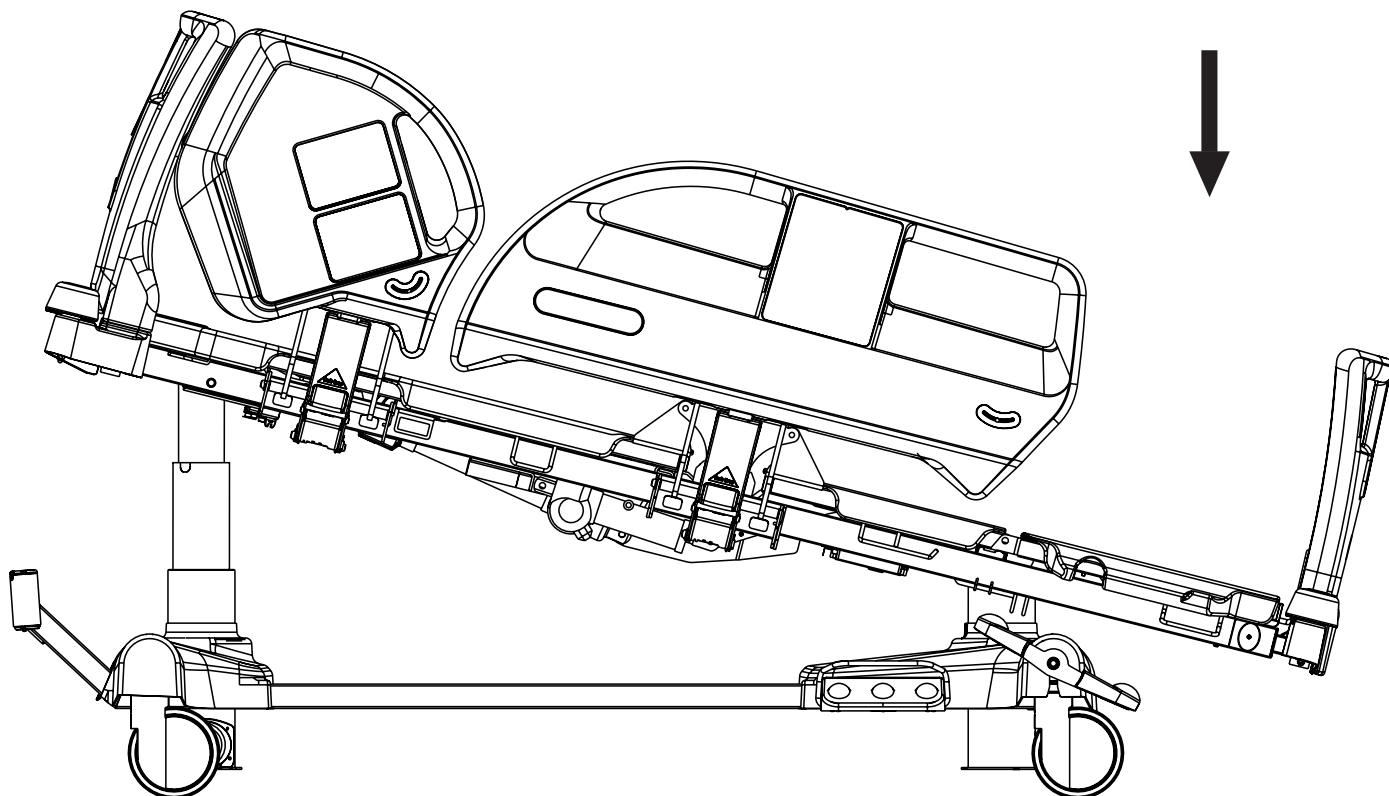

Fig. Anti-Trendelenburg Tilt

To position Trendelenburg Tilt or Anti-Trendelenburg Tilt use:

- ▶ Nurse Control Panel
- ▶ Attendant Control Panel

Depending on configuration, the bed stops in the horizontal position (0°) during tilting.
To continue tilting press the corresponding tilt button.

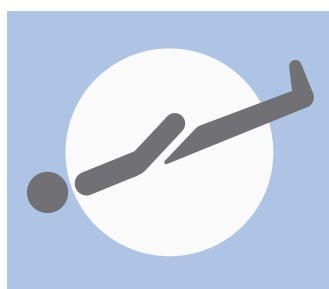



Fig. Trendelenburg Tilt Button
(Nurse Control Panel)

Nurse Control Panel:

- ▶ Press button .
- ▶ Press Trendelenburg Tilt Button until intended position is reached.

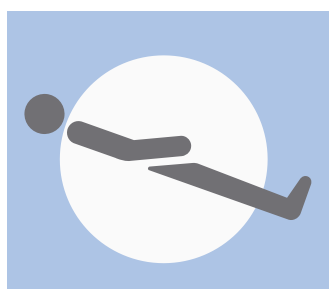
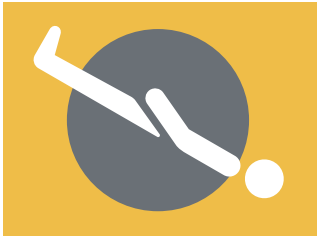

Fig. Anti-Trendelenburg Tilt Button
(Nurse Control Panel)

Nurse Control Panel:

- ▶ Press button .
- ▶ Press Anti-Trendelenburg Tilt Button until intended position is reached.



*Fig. Trendelenburg Tilt Button
(Attendant Control Panel)*

Attendant Control Panel:

- ▶ Press button  .
- ▶ Press Trendelenburg Tilt Button until intended position is reached.

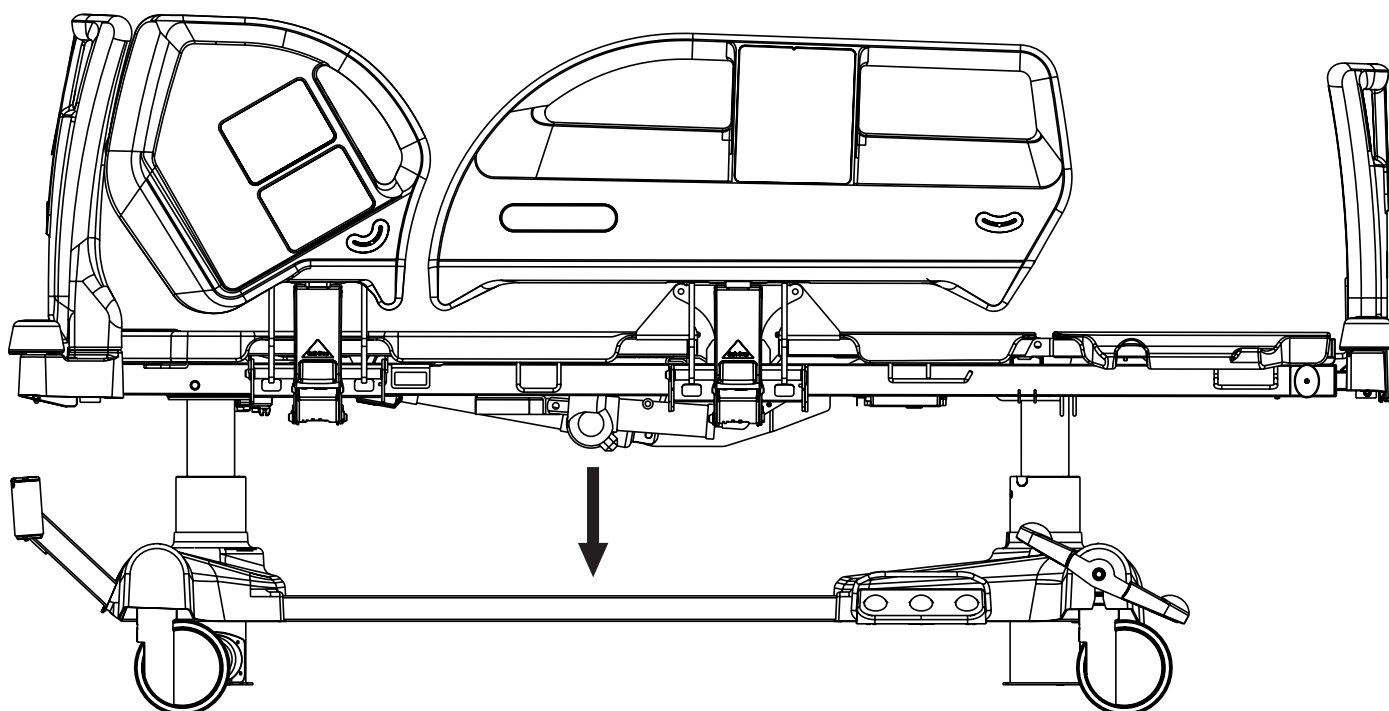

*Fig. Anti-Trendelenburg Tilt Button
(Attendant Control Panel)*

Attendant Control Panel:

- ▶ Press button  .
- ▶ Press Anti-Trendelenburg Tilt Button until intended position is reached.

11.5.9 CPR Position



To position CPR Position use:

- ▶ Nurse Control Panel
- ▶ Attendant Control Panel

In CPR Position the mattress support platform is adjusted to the low position and all the parts of the mattress support platform are in the basic (flat) position.



Fig. CPR Position Button (Nurse Control Panel)

Nurse Control Panel:

- ▶ Press CPR Position Button until intended position is reached.



Fig. CPR Position Button (Attendant Control Panel)

Attendant Control Panel:

- ▶ Press CPR Position Button until intended position is reached.

11.5.10 Mechanical Bed Extension

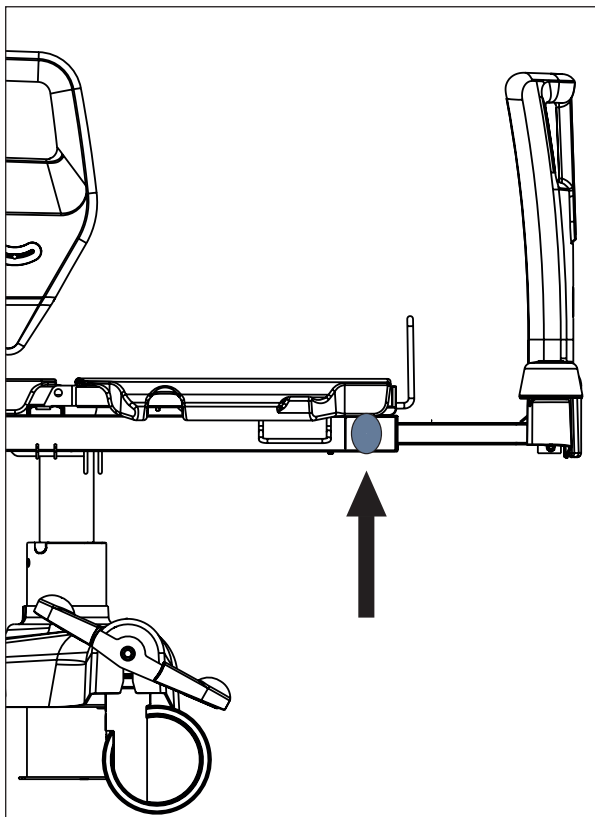
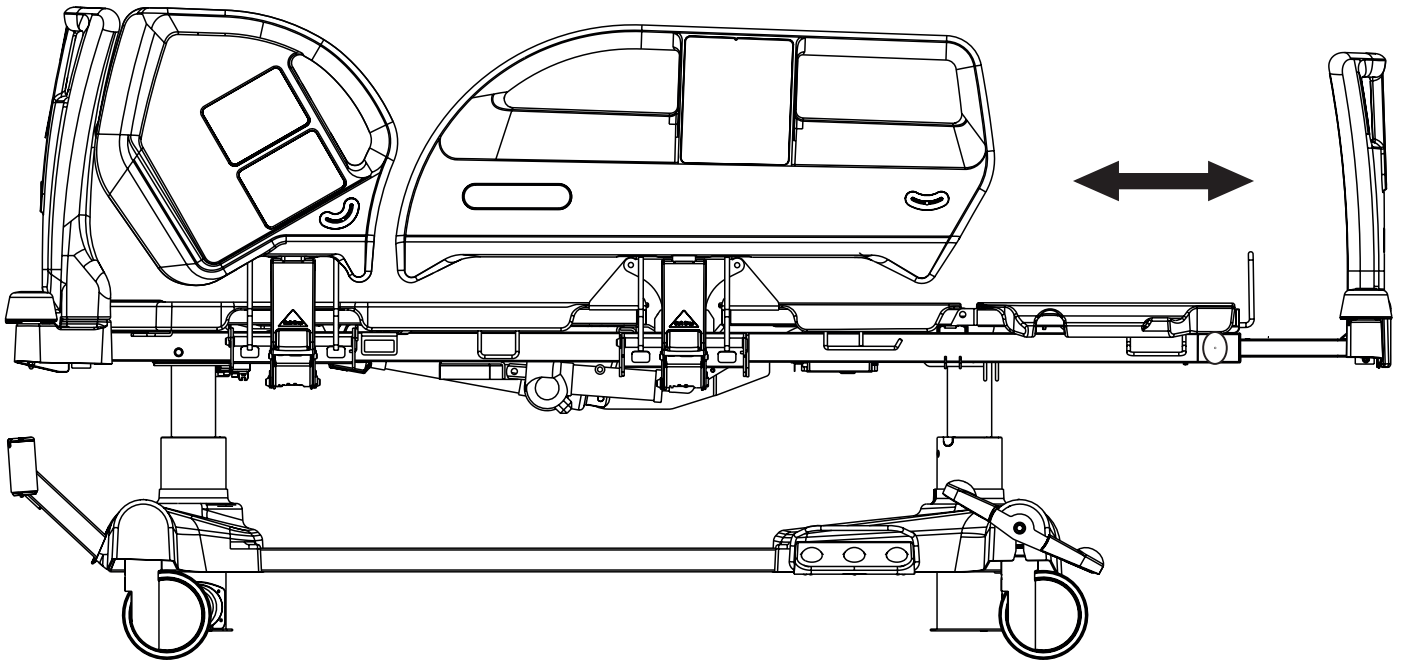

Fig. Position of Bed Extension Safety Catch

There are 2 positions of the Bed Extension.

To extend the bed:

- ▶ Pull out the Safety Catches at Foot End on the both sides of the frame.
- ▶ Turn the Safety Catches by 90°. The Safety Catches are released.
- ▶ Pull the Foot Board to the selected position.
- ▶ Turn the Safety Catches by 90° and push them in to fix the extension position.

To shorten the bed:

- ▶ Pull out the Safety Catches at Foot End on both sides of the frame.
- ▶ Turn the Safety Catches by 90°. The Safety Catches are released.
- ▶ Push the Foot Board to the selected position.
- ▶ Turn the Safety Catches by 90° and push them in to fix the extension position.

Mattress Holder

It is possible to adjust Mattress Holder when the bed without mattress is extended.

To adjust the Mattress Holder:

- ▶ Remove the Calfrest cover from the mattress support platform.
- ▶ Insert the catches on both sides of the Mattress Holder to the selected positions.
- ▶ Put the Calfrest cover back to its place on the mattress support platform.

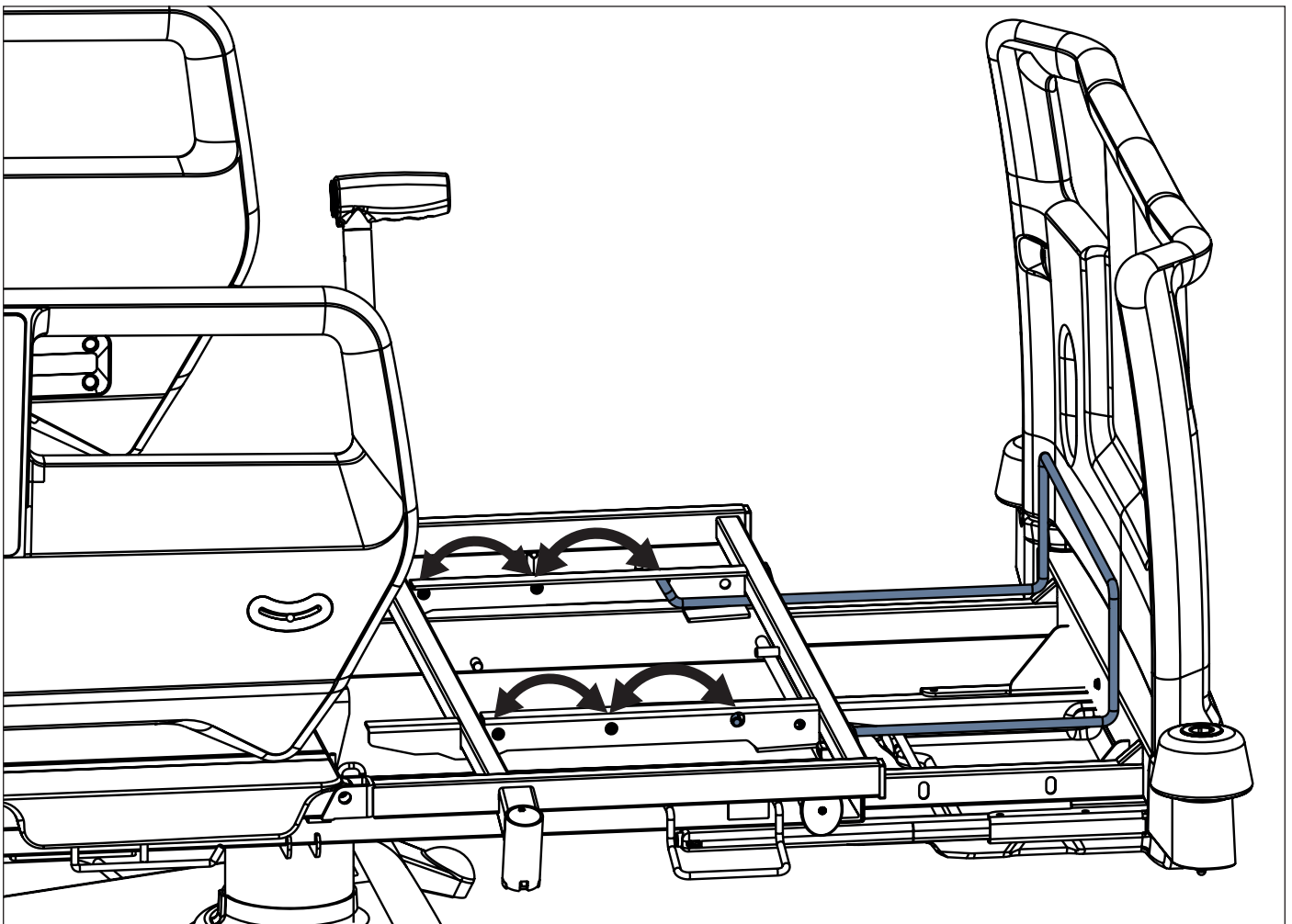

Fig. Adjustment of the Mattress Holder

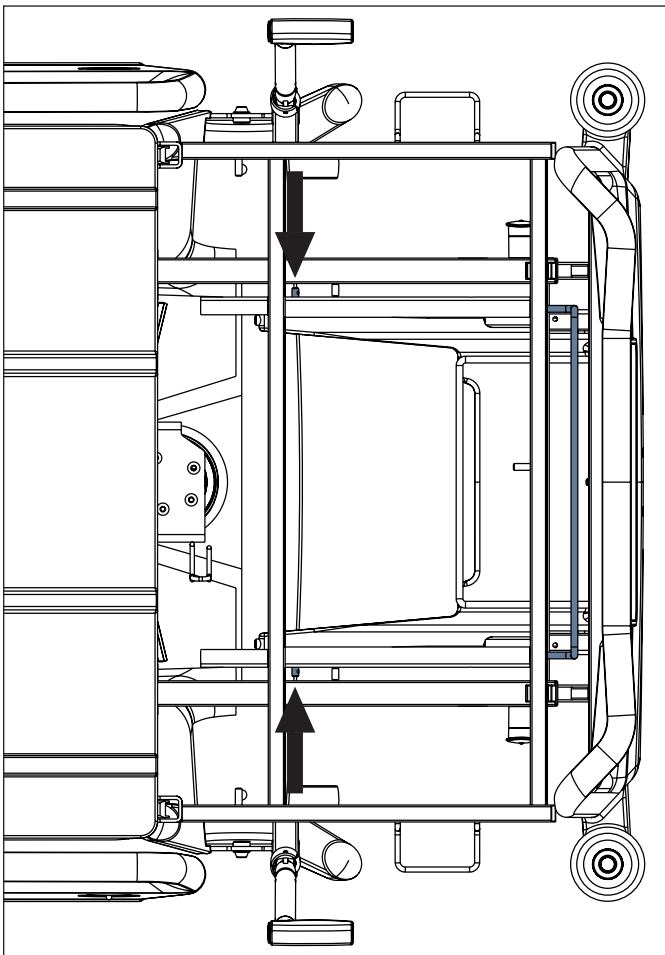

Fig. Basic position of the Mattress Holder

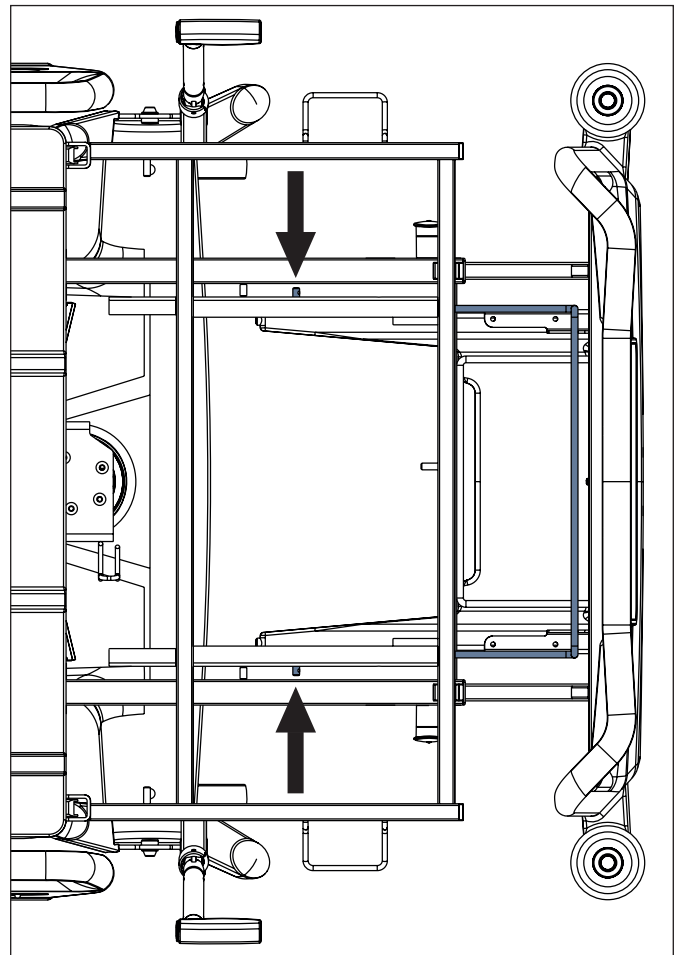

Fig. First extension of the Mattress Holder

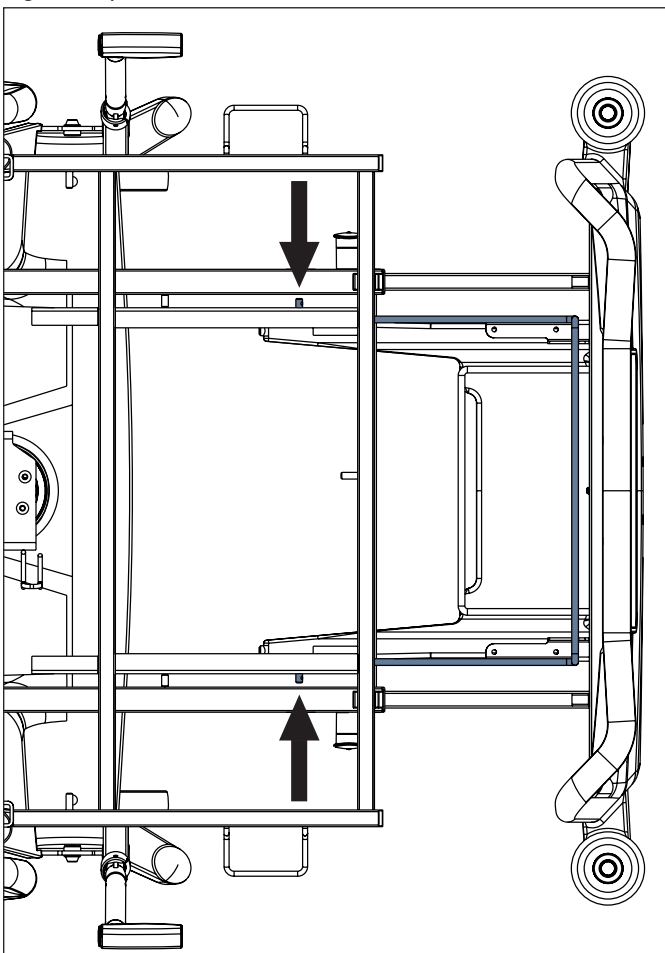
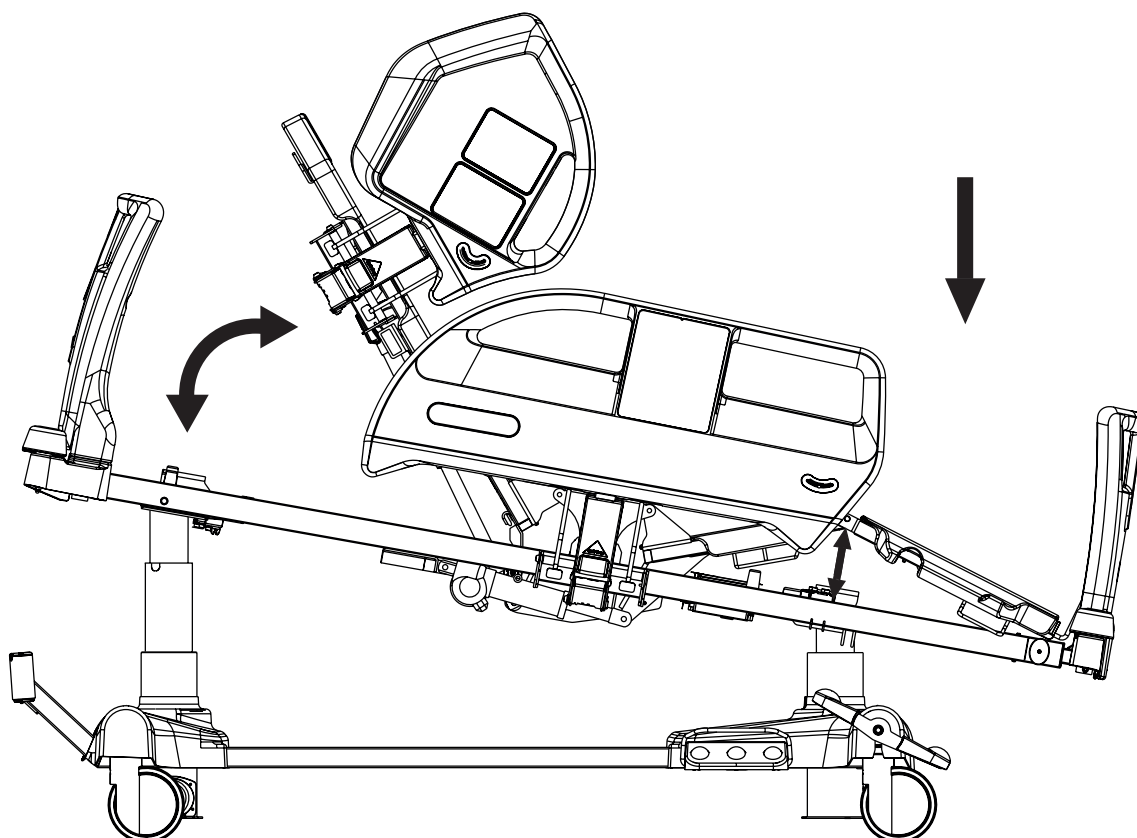

Fig. Second extension of the Mattress Holder

11.5.11 Cardiac Chair Position



To position Cardiac Chair Position use:

- ▶ Nurse Control Panel
- ▶ Attendant Control Panel



Fig. Cardiac Chair Position Button (Nurse Control Panel)

Nurse Control Panel:

- ▶ Press button .
- ▶ Press Cardiac Chair Position Button until intended position is reached.

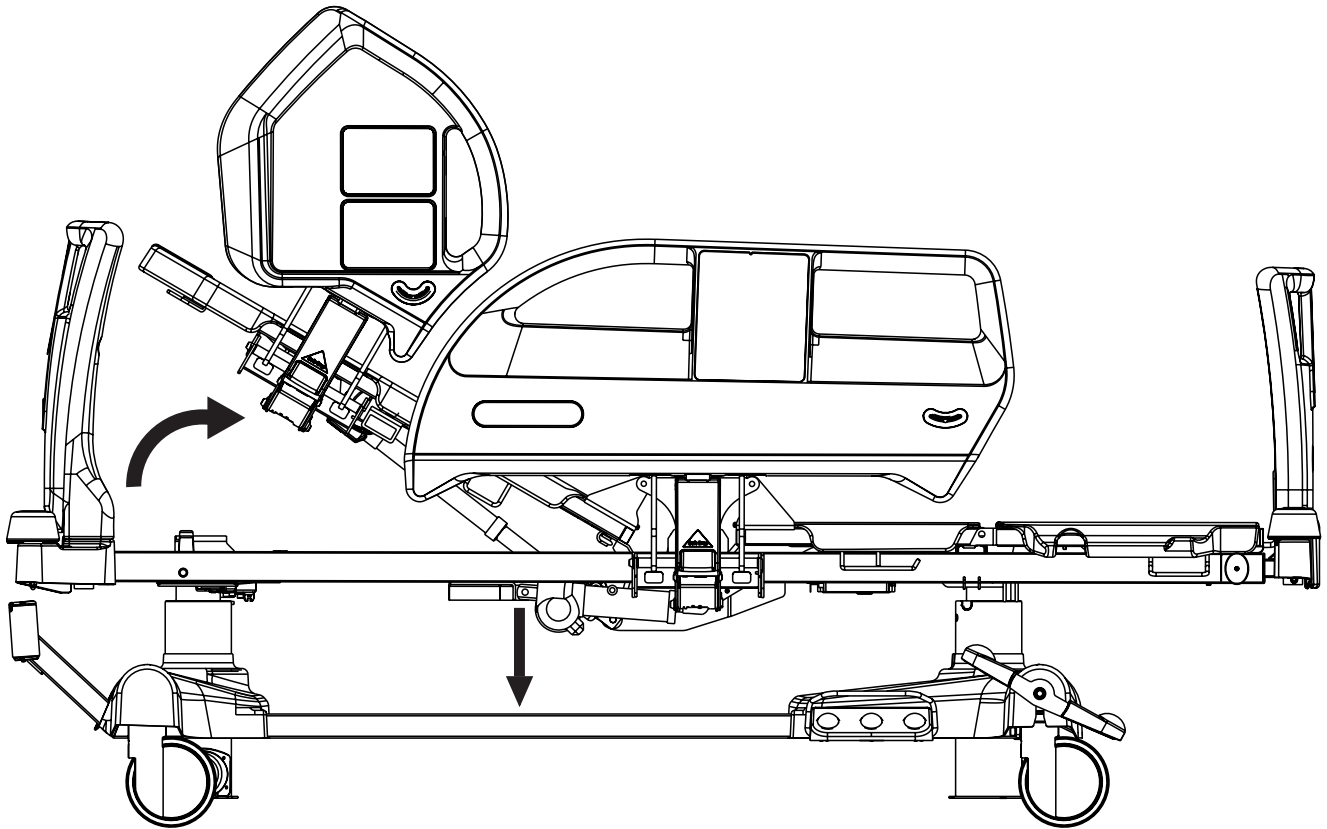

Fig. Cardiac Chair Position Button (Attendant Control Panel)

Attendant Control Panel:

- ▶ Press button .
- ▶ Press Cardiac Chair Position Button until intended position is reached.

11.5.12 Mobilisation Position



To position Mobilisation Position use:

- ▶ Nurse Control Panel

In Mobilisation Position bed is descending to the lowest Bed Height and Backrest reaches the maximum angle.



Fig. Mobilisation Position Button (Nurse Control Panel)

Nurse Control Panel:

- ▶ Press button .
- ▶ Press Mobilisation Position Button until intended position is reached.

11.5.13 Ergoframe

Ergoframe® is the kinematic system of Backrest and Thighrest Adjustment resulting in extension of the Mattress support platform in the seat section.

Ergoframe® enlarges the space for pelvic area during Auto-contour. Because of increasement of the space the force applied results in decrease of the pressure that can cause pressure injuries in the pelvic area.

Ergoframe maintains a stable ergonomic position of the body and spine of the patient, thus limiting unwanted movement of the patient by moving down or up in beds. Unified movement eliminates the patient's shift over the mattress and thus maintains a uniform position of the patient's body that is not bound to the position of the bed parts.

12 Scales Control (only version with scales)

Use iBoard Basic to control the scales.

iBoard Basic

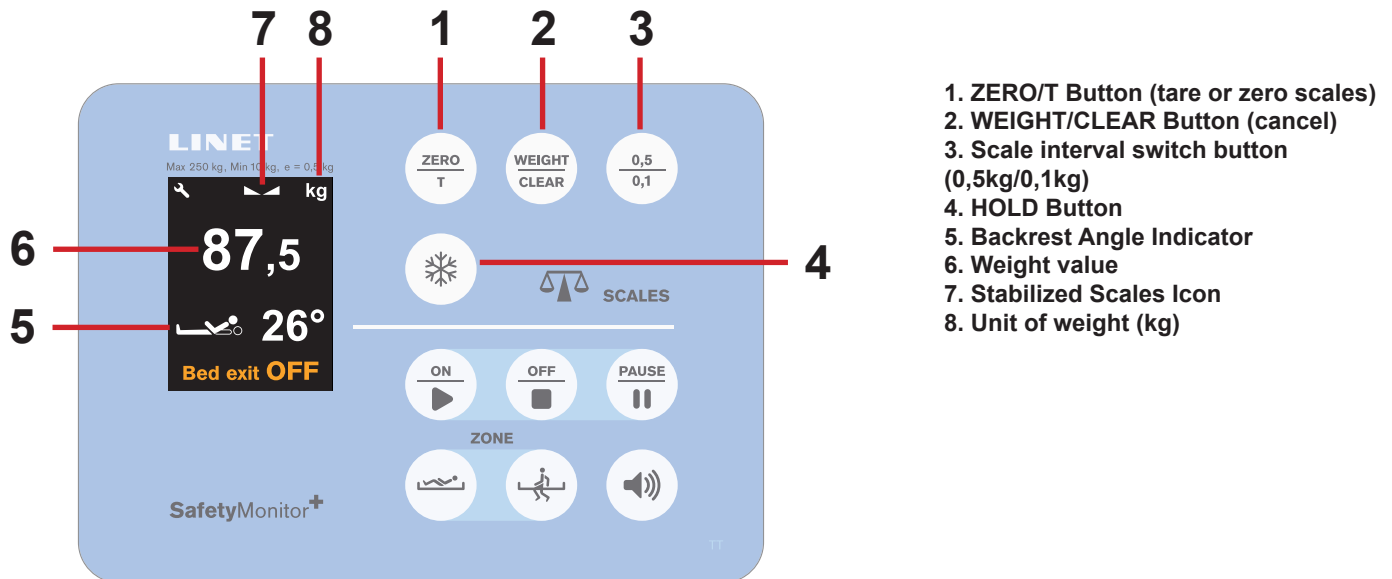

Fig. Scales Section (iBoard Basic) - display and keyboard

12.1 Preparation

- ▶ Install mattress and accessories to prepare bed before patient admission and using the scales.





CAUTION!
Incorrect use of scales due to incomplete preparation!
 ▶ Before each patient admission tare the scales.

12.2 Taring

Taring can be done in a range of 5kg to 249.5kg. Taring is used to set “0” on the display before placing the patient on the bed. Taring must be done with an unloaded bed with mattress, bed sheets, pillows and necessary accessories, without the patient. It is recommended to position Mattress support platform about 20 cm above the lowest horizontal position.

To tare weight:

- ▶ Ensure that nothing and nobody touches the bed except you.
- ▶ Press and hold button  until value (6) starts to flash. Release button .
- ▶ Press button  again to confirm taring. “0” is shown on the display.

Place the patient on the bed.

To cancel taring:

- ▶ Press button  while taring.

12.3 Displaying

Verification Scale Interval is 0.5 kg.

- ▶ Press button  to display value with actual scale interval 0,1 kg for 5s.

Unit of weight (**kg**) and decimal point are flashing on the display during this mode.





Field 6 shows actual weight value that remains displayed on the display.

If the bed is configured as EMR ready weight value automatically disappears after 1 minute and bed picture appears instead of it on the display. If it is needed, press button  to display weight value again.



12.4 Hold Mode

Hold Mode can be used only when scales are stabilized.
It allows adding or removing bed accessories and other items without changing the weight value.

To activate Hold Mode:

- ▶ Wait until the scales are stabilized. The icon  or  will be illuminated when the scales are stabilized.
- ▶ Press button  until snowflake icon  appears on the display.
- ▶ Add or remove required accessories.

To deactivate Hold Mode:

- ▶ After adding or removing accessories wait until the scales are stabilized (icon  or  is displayed).
- ▶ Press button .
- ▶ Display shows the original weight value.

To deactivate Hold Mode without fixing the weight value:

- ▶ Press button .

12.5 Bed Overload

If load of the bed is over 254,5 kg:

- ▶ The „HIGH“ is shown on the display.

If load of the bed is over 260 kg:

- ▶ The „OVERLOAD“ is shown on the display.

NOTE If the bed is overloaded, it is impossible to position or manipulate the bed until overloading is removed.

NOTE Bed overloading always has higher priority than Hold Mode and Taring.

12.6 Bed Underload

If the bed is underloaded:

- ▶ Display shows the „LOW“.

12.7 Weighing in tilt



Accuracy is conditioned by the spirit level, which is located on the right head corner of the bed.
If the bubble is in the highlighted circle then weighing is accurate.

12.8 Zeroing Scales

Zeroing is only possible in a range of ± 5 kg from factory zero.

Zeroing is used to reset weight on the display and set up user zero, which sets the maximum weight range of the weighing system. Zeroing must be done with an empty, unloaded bed, without the mattress and accessories. Zeroing is done after installation, weight verification or servicing.

To zero scales:

- ▶ Position the bed about 20 cm above the lowest position and set the mattress support platform to the horizontal position. Ensure that nothing touches the bed except you.
- ▶ Press and hold button  until weight value starts to flash.
- ▶ Press button  to confirm zeroing.

“0” is shown on the display and an acoustic signal confirms zeroing.

To cancel zeroing:

- ▶ Press button  while zeroing.



Fig. HOLD Mode (iBoard Basic)



Fig. High Load (iBoard Basic)



Fig. Bed Underload (iBoard Basic)

13 Bed Exit Monitoring (only version with scales)

Use iBoard Basic to control the Bed Exit Monitoring.

If the bed is equipped with SafetyMonitor (accessory), Bed Exit Monitoring function is included between the functions of the SafetyMonitor.

iBoard Basic

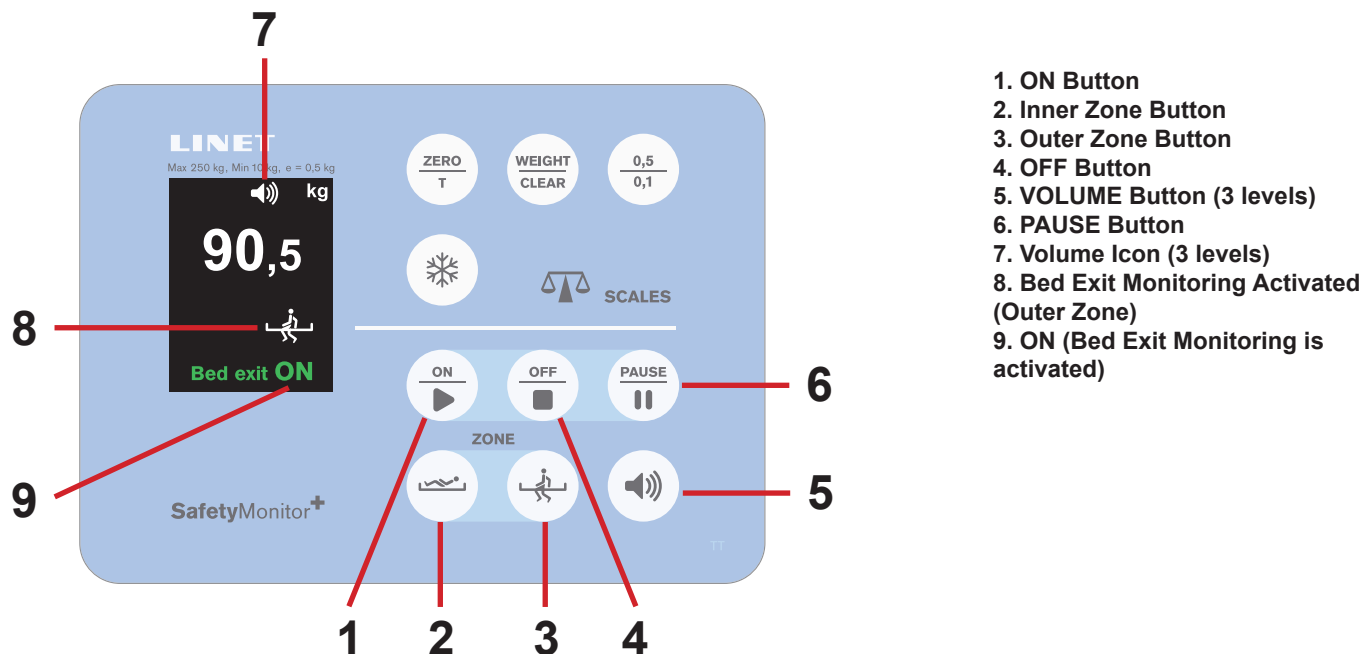

Fig. Bed Exit Monitoring Section (iBoard Basic) - display and keyboard

13.1 Preparation

- ▶ Place a patient on the bed with suitable mattress.
- ▶ For the correct Bed Exit Monitoring in the Inner Zone patient's position in the middle of the bed is needed.

13.2 Activation of Bed Exit Monitoring

Bed Exit Monitoring is **OFF** and icon **OFF** is displayed by default.

To activate Bed Exit Monitoring:

- ▶ Press button .

Icon **ON** appears on the display.

When Bed Exit Monitoring is activated Inner Zone is set by default. Icon  therefore appears on the display.

NOTE Minimum patient weight for Bed Exit Monitoring is 35 kg.

13.3 Monitored Zone

To switch to the Outer Zone:

- ▶ Press button .

Icon  appears on the display.

To set the Inner Zone again:

- ▶ Press button .

Icon  appears on the display.

13.4 BED EXIT ALARM

Alarm is triggered when patient has left selected monitored zone or PAUSE period elapsed and patient is not in ordered position.

To stop Alarm:

- ▶ Press button .

Bed Exit Monitoring is deactivated and icon **OFF** appears on the display.

The audible alarm is stopped.

To pause Alarm:

- ▶ Press button  or button .

„Pause 15 min.“ appears on the display and 15 minute countdown timer runs.

The audible alarm is paused.

13.4.1 Alarm Volume

Maximum Alarm Volume Level is set by default.

It is possible to set Alarm Volume before and during triggered alarm.

To lower Alarm Volume Level:

- ▶ Press button .

Icon  with lower Alarm Volume Level appears on the display. Volume is lowered.

To return to Maximum Alarm Volume Level:

- ▶ Press button  after Minimum Alarm Volume Level has been reached.

Icon  with the 3 levels appears on the display.

13.5 PAUSE

During PAUSE Mode Bed Exit Monitoring is temporarily interrupted and Alarms are not activated. When Outer Zone monitoring is activated, PAUSE period is terminated when patient returns to the bed within 15 minutes of the PAUSE period.

To PAUSE Bed Exit Monitoring:

- ▶ Press button  or button .

Icon **10** appears on the display with 15 minute countdown timer.

After PAUSE period elapsed and patient is in ordered position Bed Exit Monitoring is reactivated.

To extend the PAUSE period:

- ▶ Press button  again to extend the countdown to 15 minutes period again.

To terminate the PAUSE period:

- ▶ Press button .

13.6 Deactivation of Bed Exit Monitoring

To deactivate Bed Exit Monitoring:

- ▶ Press button .

Icon **OFF** appears on the display.



Fig. Visual signalisation of Bed Exit Alarm (iBoard Basic)

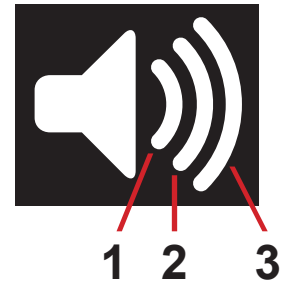

Fig. Volume Icon

1. Minimum Volume
2. Moderate Volume
3. Maximum Volume

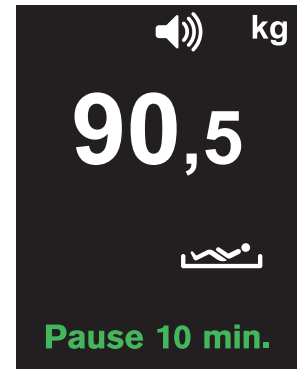

Fig. PAUSE Countdown (with remaining minutes)



Fig. Bed Exit OFF (iBoard Basic)

14 Equipment

14.1 Accessory Rail with plastic hooks (optional)

Accessory Rail with 2 plastic hooks is intended for hanging accessories.
It is located on the sides of bed.

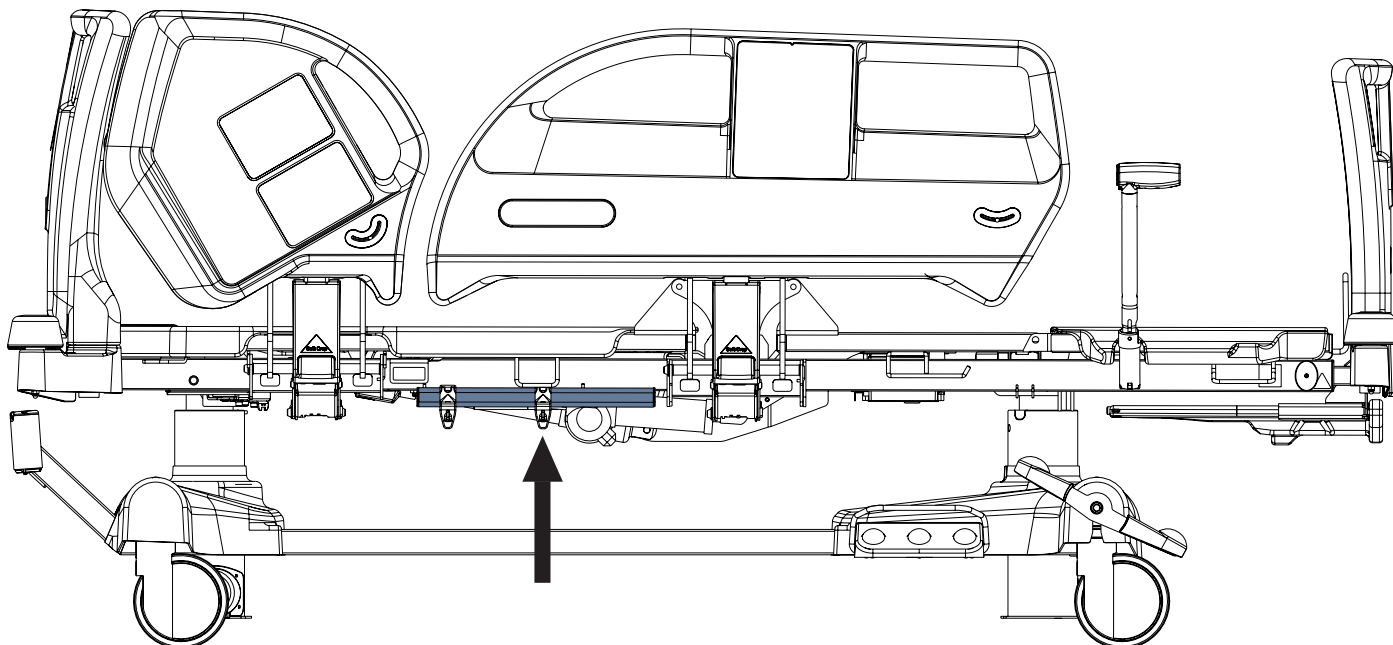

Fig. Accessory Rail with plastic hooks (on side)

14.2 Linen Shelf (standard)

Linen Shelf is intended for storing the things corresponding to its dimensions (e.g. linens or sheets).
The Attendant Control Panel can be stored in the Linen Shelf.
The Linen Shelf is located at foot end under the Foot Board.
Safe Working Load of the Linen Shelf is 15 kg.

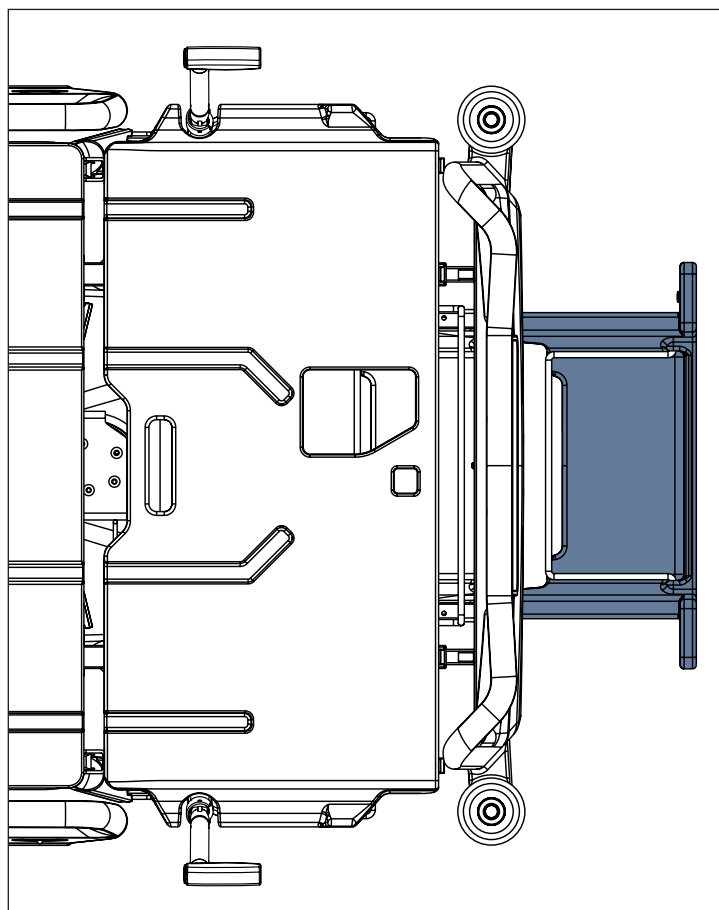

Fig. Linen Shelf (at foot end)

14.3 Mobi-Lift® (optional)



WARNING!

Risk of injury due to slipping or falling when standing up!

- ▶ Ensure that the Mobi-Lift handles are completely inserted in the sleeve fittings.
- ▶ Ensure that no bed linen is caught between the sleeve fitting and the support handle.

Mobi-Lift® is optional. It serves as a support handle to enhance the patient's safety when getting up. Mobi-Lift® is a support handle with a built-in Height Adjustment button. It allows the patient to raise and lower the Mattress support platform.

Using the Mobi-Lift handles

To adjust the Mobi-Lift handle:

- ▶ Lift the handle up towards the bed.
- ▶ Push the handle into the sleeve fitting as far as it will go.

To adjust the height of the mattress support platform:

- ▶ Press button  on any control element.
- ▶ Press the button to adjust the bed height.

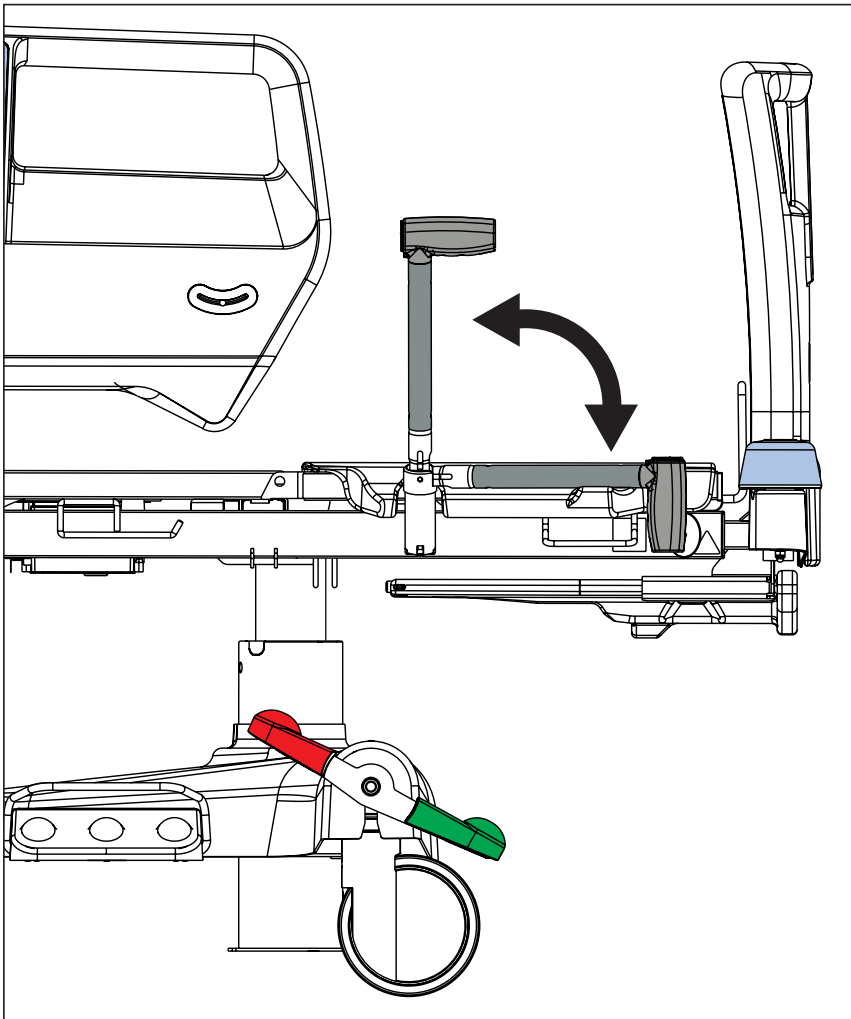

Fig. Mobi-Lift Handle

14.4 Brake Signal (optional)

If bed is equipped with Brake Signal and this bed is connected to the mains power, the Brake Signal sounds when the bed is not braked.

14.5 i-Brake® (optional)

It is possible to equip the bed with an automatic castor brake. The automatic castor brake prevents injuries of patients and staff due to an unbraked bed. The brakes are activated automatically 60 seconds after the bed is plugged in, and 60 seconds after they have been released if the bed is not being moved. It is possible to activate the brakes manually as well.

14.6 Retractable Fifth Castor (optional)

It is possible to equip the bed with Fifth Castor in the centre of undercarriage. The Fifth Castor helps to steer and manoeuvre the bed in long corridors and small rooms. Retracted Fifth Castor does not obstruct access to any devices under the undercarriage.

14.7 LINIS SafetyPort (optional)

LINIS SafetyPort is a medical device data system for capturing and transferring data from LINET beds into SafetyPort Dashboard and third party systems, including nurse calls, EHR and digital whiteboards. Data collection and evaluation takes place at one central location for all beds connected to the system simultaneously. The records are completely anonymous and the system does not work with any personally identifiable information. The customer can decide which data will be sent to the 3rd party system and adjust their sending period. LINIS SafetyPort is intended to be used to increase efficiency of healthcare personnel workflows by saving their time spent on documentation and eliminating errors. This is achieved by automated recording of different parameters of medical beds and their subsequent transfer to various hospital systems in HL7 format. Optional feature LINIS SafetyPort Dashboard is intended to save time the healthcare personnel spends on checking different beds at their workspace and to provide them with both near-real-time data and their aggregation to be able to check the history of provided care. LINIS SafetyPort may be used in various healthcare environments, including both intensive and non-intensive care units as well as units providing speciality care to a broad population of patients. The product is intended to be used by variety of healthcare personnel who have the cognitive skills to operate the product and are trained to use the product. LINIS SafetyPort is not an alarm system and the use of this product for this purpose means incorrect use.

14.8 i-Drive Power (optional)

14.8.1 i-Drive Power System - Basic Description

It is possible to equip the bed with the i-Drive Power wheel. The i-Drive Power helps hospital staff to drive the bed during patient transport with minimal manpower.

The i-Drive wheel is located in the center of the bed under the undercarriage. i-Drive Power is equipped with its own accumulator and charger and it is not dependent on the bed functions so, if discharged you can still use the bed functions. The bed is equipped with one i-Drive controller. i-Drive is oriented in straight direction of the bed.

14.8.2 Safety instruction for i-Drive Power

- ▶ Follow the instructions carefully.
- ▶ Ensure that the bed is operated exclusively by qualified staff.
- ▶ Make sure the siderails are raised up during the transport.
- ▶ Never use bed positioning buttons during transport.
- ▶ Never use Fast forward button when descending. The Fast forward button is recommended for use when ascending as it is more efficient.
- ▶ Special precaution need to be considered when reversing. Always keep distance from the bed and never use reverse button when descending or ascending.
- ▶ Do not use Free Drive to transport on a slope over 1 degree unless adequate personnel are available to manage safe bed transport.
- ▶ The driving down the slope that exceeds 6 degrees will require adequate contribution of a manpower.
- ▶ Never leave the bed with an activated i-Drive Power system without supervision of the trained staff.
- ▶ Always use the regular mechanical brake system to brake and stabilize the bed.
- ▶ Pay increased attention when driving the bed using i-Drive Power. Be aware of people and objects in close proximity and avoid collision with them by careful driving, especially by appropriate speed control.
- ▶ Make sure the bed is unplugged and bed brakes are released before using i-Drive Power.
- ▶ Push the emergency stop drive button if immediate movement interruption is needed (e.g. to avoid collision with other persons or objects).
- ▶ Retract the i-Drive Power wheel to the undercarriage when parking. This will prevent misuse when unbraking and braking the bed.
- ▶ The i-Drive Power electromagnetic brake is designed just for temporary bed stop and not for the permanent parking.
- ▶ Switch off the i-Drive Power accumulator prior to long-term storage or transport.
- ▶ Push the emergency retraction button under the chassis cover to retract the i-Drive Power wheel
- ▶ in case an of i- Drive Power system failure. This will enable moving the bed to a safe area manually without using i-Drive Power.
- ▶ Retract the i-Drive Power wheel to the undercarriage every time you intend to move the bed sideways.
- ▶ Pay attention to the LED accumulator status indicator and plan your drive using the i-Drive Power accordingly. Insufficient accumulator capacity can cause unexpected complications and risks during the drive.
- ▶ Always plug the bed in when you finish your drive in order to recharge the accumulator and keep your bed ready to go using the i-Drive Power.
- ▶ The i-Drive Power accumulator must be replaced every 2 years to maintain proper functions of the i-Drive Power.

14.8.3 Specifications of Use



WARNING!

Risk of injury due to careless driving!

- ▶ Always drive safely and carefully.
- ▶ Observe the path for any obstacles and avoid collisions.
- ▶ Ensure there are no people in your way.
- ▶ Manipulate with the bed carefully not to drive over any staff or patients.



CAUTION!

Maximal clearance underneath the bed is 11,3 cm!

- ▶ Observe the path for any obstacles and avoid collisions.

Intended use:

- ▶ bed transport (with or without patient) by the hospital staff

Unintended use:

- ▶ riding the bed
- ▶ other usage than described in instructions for use
- ▶ by other person than the trained staff

NOTE Each bed can transport only single patient at a time and cannot be used to transport other items (except bed accessories in secured position).

NOTE For information concerning uses other than those outlined in the “Specifications of Use” section above, please contact LINET®.

14.8.4 Manipulation



CAUTION!
Damage to i-Drive Power main control panel cable due to wrong cable placement!

- ▶ Ensure that the main control panel connecting cable is placed correctly.



CAUTION!
Material damage due to incorrect use!

- ▶ Do not hang anything on the main control panel and its cable!

1. Safety Sense (touch sensor)
2. Main Control Panel
3. Main Control Panel Cable – correct cable placement
4. Activation Panel

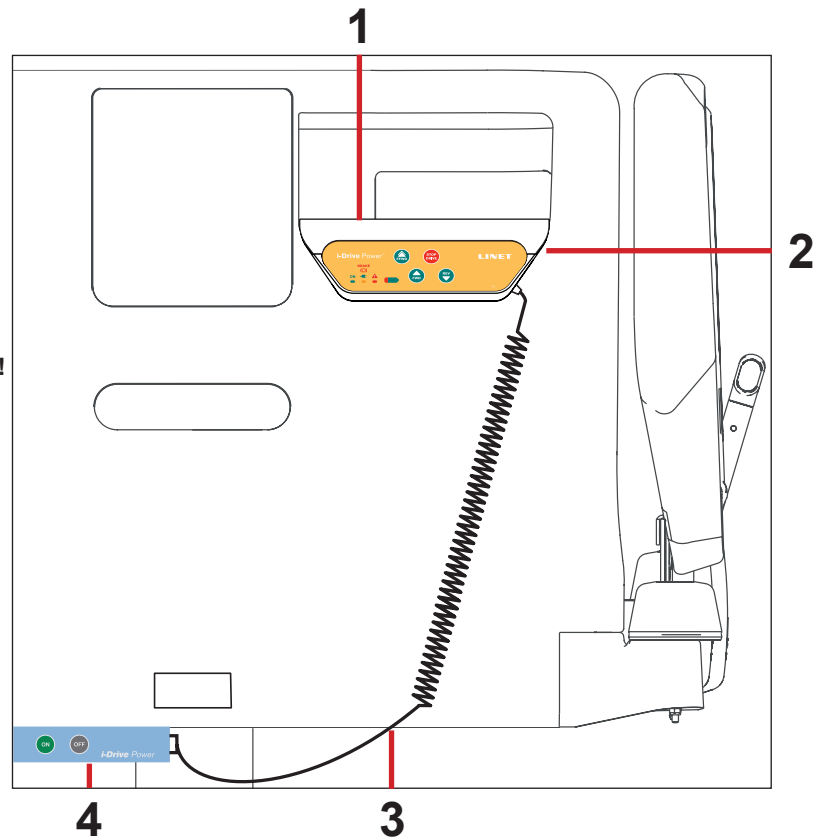

Fig. Position of Main Control Panel

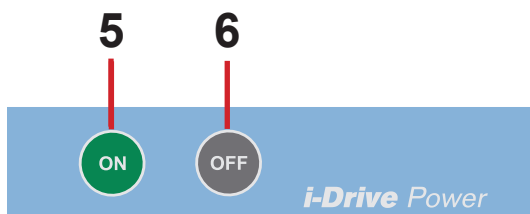

Fig. Activation Panel (4)

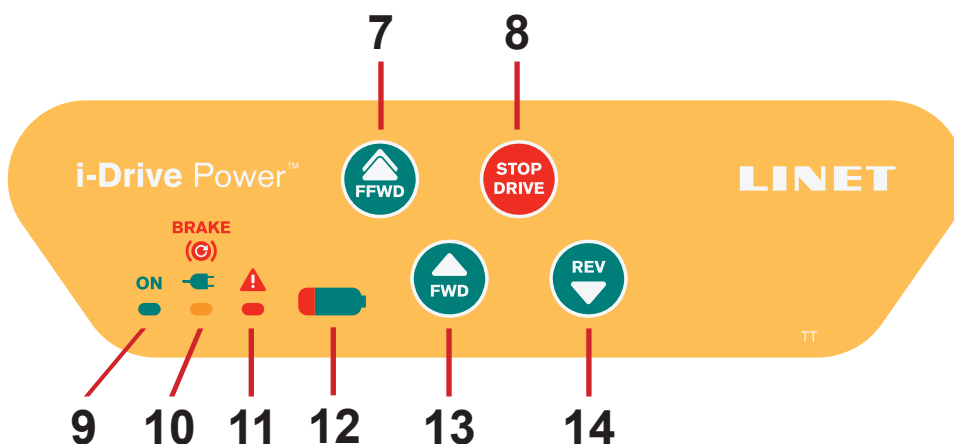

Fig. Main control panel (2)

5. ON Button (i-Drive Wheel Activation Button)
6. OFF Button (i-Drive Wheel Retraction and Deactivation Button)
7. FAST FORWARD Button
8. STOP DRIVE Button
9. ON LED
10. Mains Power LED (bed connected to the mains or bed braked)
11. Fault LED
12. State of charge and Fault LED
13. FORWARD Button
14. REVERSE Button

NOTE The i-Drive Power controller cannot control the bed functions. Control the bed using the bed control elements.

NOTE The main control panel is enhanced with a touch sensor (1); your hand must always be in contact with the i-Drive Power control panel to use the functions. If released, the i-Drive Power will stop.

NOTE Raising and lowering of the i-Drive wheel is electrically controlled by the i-Drive activation panel.

14.8.5 i-Drive Power Activation/Deactivation

To activate the i-Drive Power:

1. Check, if the mains switch of i-Drive Power is activated.
2. Press the Activation button  located on the Activation Panel. The i-Drive wheel will lower and the green indicator will flash.

To deactivate the i-Drive Power:

1. Retract the i-Drive wheel using the button  located on the Activation Panel.
2. Deactivate the i-Drive using the mains switch.

Emergency i-Drive Power wheel retraction:

1. Press any button  on the bed.
2. Deactivate the i-Drive Power using the mains switch.
3. Press the i-Drive Power Emergency Retraction Button situated on the bottom side of undercarriage under the label.

NOTE Use emergency retraction in case of accumulator discharge or drive malfunction to move the bed to a safe area manually without using i-Drive Power.

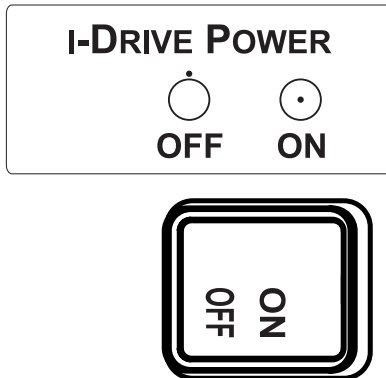
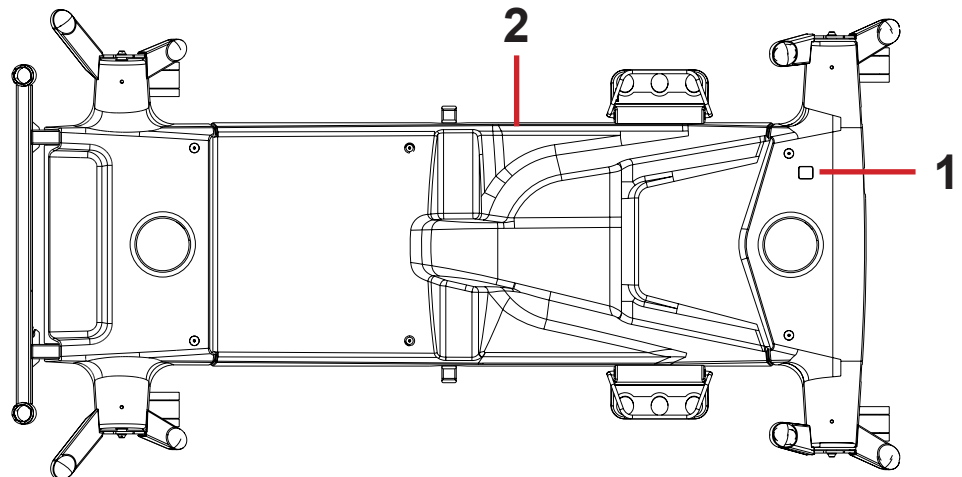

Fig. i-Drive Power Mains Switch with Label



1. i-Drive Power Mains Switch
2. i-Drive Power Emergency Retraction Button

TO RETRACT THE I-DRIVE POWER WHEEL IN EMERGENCY:

1. PRESS ANY GO BUTTON ON THE BED
2. SWITCH OFF THE MAIN POWER SWITCH
3. HOLD THE EMERGENCY RETRACTION BUTTON UNDER THE CHASSIS COVER



Fig. i-Drive Power Emergency Retraction Button Label







14.8.6 Powered Drive



CAUTION!

Damage to property due to incorrect transport and involuntary movement!



- ▶ Prior to transport, ensure that the bed is disconnected from the mains.
- ▶ Prior to transport, ensure that the auxiliary outlet plug (if available) is disconnected from the mains.
- ▶ Ensure that the castors are locked prior to assembly, disassembly and maintenance (e.g.: i-Drive Power maintenance).
- ▶ Ensure that the castors are locked when the bed is occupied.
- ▶ Hang the mains cable on the appropriate hook on the bed during transport.

1. Check, if the mains switch of i-Drive Power is activated.
2. Press the button  on the Activation Panel. The i-Drive wheel will lower and the LED  will flash.
3. Place your hand on the Safety Sense touch sensor (1) and push the button  or button  or button . Your hand must be placed on the Safety Sense sensor to use the i-Drive Power, if released, the i-Drive Power will stop.
4. The i-Drive motor is immediately stopped and the electric brake is activated after pressing the red button  when braking or in emergency.
5. i-Drive Power control system is automatically deactivated and the electric brake is activated if no i-Drive function is used for 3 minutes. This is signaled by the green LED  which is extinguished after 3 minutes.

NOTE i-Drive Power is not designed for ascending or descending a slope greater than 6° or longer than 20 m. The support of personnel is needed when ascending or descending with a full SWL.

NOTE When i-Drive wheel is lowered, it is not possible to move the bed sideways. Press the button  to retract the wheel, release the castors to the neutral position and then move the bed to any direction required.

14.8.7 Braking



1. Press and hold the button  to brake immediately.
-or-
2. Press and hold the button  to brake slowly (Press the button  to brake when reversing).
-or-
3. Release your hand from the touch sensor area and i-Drive Power will brake automatically.

NOTE Always brake the bed by using the castor control lever when the transport is finished or interrupted. The i-Drive electromagnetic brake is not designed to permanently brake the bed.

NOTE In a crisis situation (e.g. acceleration when driving down a steep slope) i-Drive dual braking prevents acceleration and slows down bed movement. However, it is not guaranteed the bed will stop by itself without personnel support (using button  and castor control lever).

NOTE When descending, it is possible to actively brake using the opposite direction button to slow.

14.8.8 Free Drive

The i-Drive motor is equipped with free drive, which is active after pressing the forwards ( or ) or backwards () buttons (until user holds the touch sensor area). Free Drive is deactivated and the brake is activated when the direction of motion is changed. This is feature for lowering the risks when going to a slope.

14.8.9 Accumulator

Accumulator charge status:

1. **While this indicator is flashing, the accumulator is critically discharged. (LED1)**
2. **50% (LED2)**
3. **75% (LED3)**
4. **100% - the accumulator is charged (LED4)**

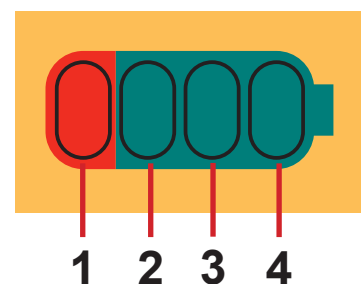

Fig. Accumulator Charge Status

To charge the accumulator:

- ▶ Connect the bed main cable to mains power.
- ▶ i-Drive will be charged (with the accumulator discharged, the charging may take up to 9 hours).

NOTE Accumulator charge values are just informational. Accumulator life is reduced when the accumulator is allowed to discharge completely.

14.8.10 Fault Signalization

The system is protected against failure states, by stopping and braking the drive system, and respective signalization. The fault indicator flashing briefly and the accumulator indicator shows the fault state. Some defects are cleared automatically (e.g.: drive overheating). When drive or electronics is overheated, an short acoustic signal occurs before the drive is blocked.

Error	LED1	LED2	LED3	LED4
Drive overheated	OFF	OFF	OFF	ON
Electronics overheated	OFF	OFF	ON	OFF
Brake error	OFF	OFF	ON	ON
Retraction not completed	OFF	ON	OFF	OFF
Internal system error	OFF	ON	OFF	ON
C losing of the Field-effect transistor is penetrated	OFF	ON	ON	OFF
Control circuit overheated	OFF	ON	ON	ON
Controlcircuiterror	ON	OFF	OFF	OFF
Activation button stuck	ON	OFF	OFF	ON
Retraction button stuck	ON	OFF	ON	OFF
Active button after start	ON	OFF	ON	ON

14.8.11 Light Indicators

Indicator	Meaning
Go Indicator ► Constantly lit ► Flashing	Hand is on touch sensor; drive wheel is ready for use. Hand is not on touch sensor; i-Drive is not ready for use.
Fault Indicator ► Constantly lit ► Flashing	i-Drive cannot be activated (i-Drive wheel is not lowered, castor control lever is braked, bed is connected to the mains). System is faulty (indicated on accumulator status indicator) -or- i-Drive control box heat protection is activated

14.8.12 Technical Specifications

Parameter	Value
i-Drive wheel diameter	8,27 in.
Max. fast forward speed (flat ground, loaded)	4,43 Km/h (±15%)
Max. forward speed (flat ground, loaded)	2,16 Km/h (±15%)
Max. reverse speed (flat ground, loaded)	2,16 Km/h (±15%)
Max. angle of ascent	6°
Noise level (when retracting the drive wheel)	65 dB

14.8.13 Electrical specification

Parameter	Value
Input Voltage, Frequency	230 V AC, 50/60 Hz 127 V AC, 50/60 Hz 120 V AC, 50/60 Hz 110 V AC, 50/60 Hz 100 V AC, 50/60 Hz
Accumulator Voltage	36 V DC, Capacity: 12 Ah
Maximum Power Input	300 W
Fuse	
Version 230 V	2 x T1,6A L 250V
Version 127 V	2 x T3,15A L 250V
Version 120 V	2 x T3,15A L 250V
Version 110 V	2 x T3,15A L 250V
Version 100 V	2 x T3,15A L 250V

14.8.14 i-Drive Power Maintenance

Periodical maintenance of the i-Drive Power must be done by qualified service technician or authorized service organization at least once a year. To continue maintenance please see chapter Maintenance.

Service technician must check the following:

- ▶ accumulator status and eventual replacement of the accumulator (after maximum of three years of duty)
- ▶ gas spring – replace if necessary (after maximum of three years of duty)
- ▶ i-Drive Power wheel – replace if necessary
- ▶ lifting mechanism – grease if necessary
- ▶ cables, control elements – replace if necessary
- ▶ i-Drive Power function

14.9 Safestop (optional)

Safestop prevents user of the bed from injuries due to crushing by the lowered Mattress support platform.

When obstacle occurs on the undercarriage and Mattress support platform is going down, the motion is automatically stopped.

iBoard Standard display shows **SAFE STOP** +  and beeping is performed.

14.10 X-Ray Examination (optional)



WARNING!

Respect maximum dimensions of x-ray cassettes!

- ▶ Maximum dimensions of any x-ray cassette for X-Ray Cassette Holder are 46,5 cm x 39 cm x 1,8 cm!



WARNING!

Prevent x-ray cassettes from being damaged!

- ▶ Do not leave any x-ray cassette in the X-Ray Cassette Holder if X-Ray Examination should not be performed!



CAUTION!

Prevent x-ray images from being devalued!

- ▶ Take x-ray images when the bed is braked and no part of the bed is forced to move!
- ▶ Follow the instructions in this instructions for use how to use the X-Ray Cassette Holder!

The Backrest of the bed consists optionally of HPL and is x-ray translucent. The bed is equipped with an x-ray cassette holder inserted under the Backrest left side. This design allows taking x-ray images of the patient's lungs without moving the patient manually.

Necessary Steps before the Examination

- ▶ Make sure that patient is in centre of bed.
- ▶ Make sure that backrest is in lowest position and siderails are raised up.
- ▶ Pull out x-ray cassette holder.
- ▶ Insert x-ray cassette in the horizontal position.
- ▶ Insert back x-ray cassette holder with x-ray cassette so that the cassette centre indicator is exactly under the edge of the mattress support platform.
- ▶ Correct position of x-ray cassette holder using the tooth mechanism so that the upper edge of the x-ray cassette is exactly under the patient's shoulder line. For the correct orientation use the scale on the label. Indicate the position of the patient's shoulder line using the numbers on the scale. Move the x-ray cassette holder in such position so that the centre of the handrail is on the respective scale number.
- ▶ Adjust parameters of the x-ray device and do the image.

NOTE This procedure is above all suitable for patients who cannot be moved due to critical conditions (e. g. internal bleeding) or unstable patients.

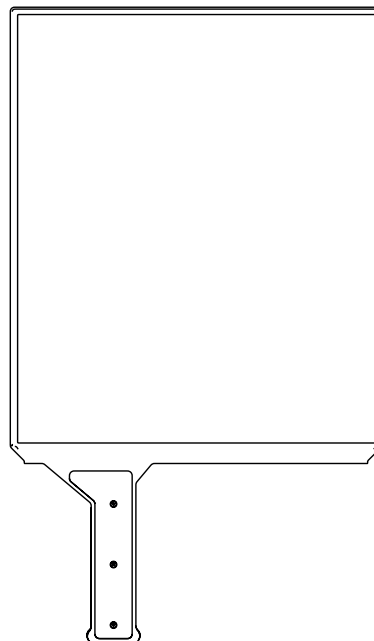
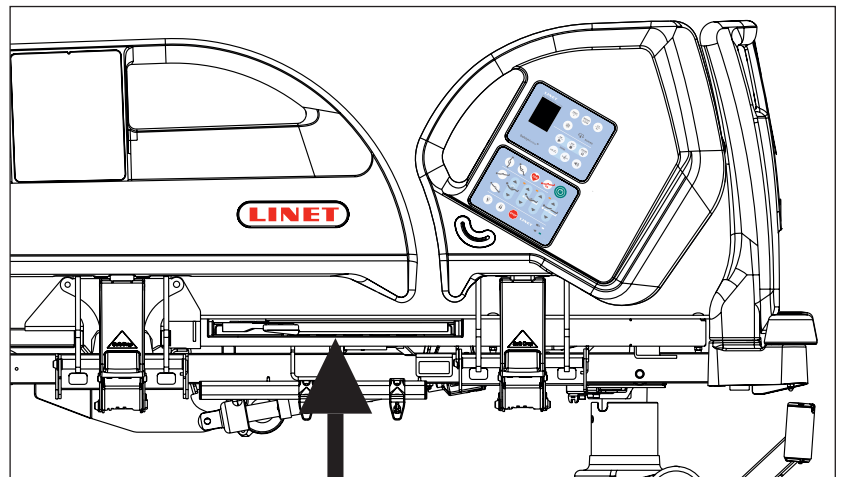

Fig. X-Ray Cassette Holder

14.11 Undercarriage Cover



CAUTION!
Risk of material damage due to objects on the undercarriage cover!
 ► Do not place objects on the undercarriage cover!

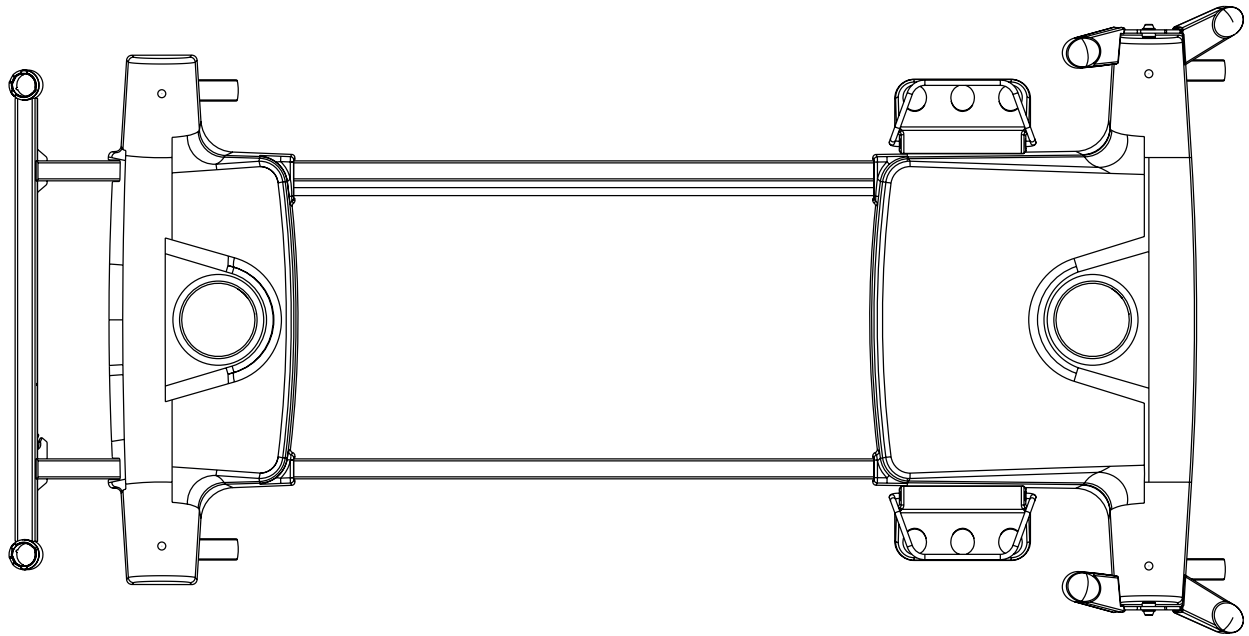

Fig. 2-part undercarriage cover (standard)

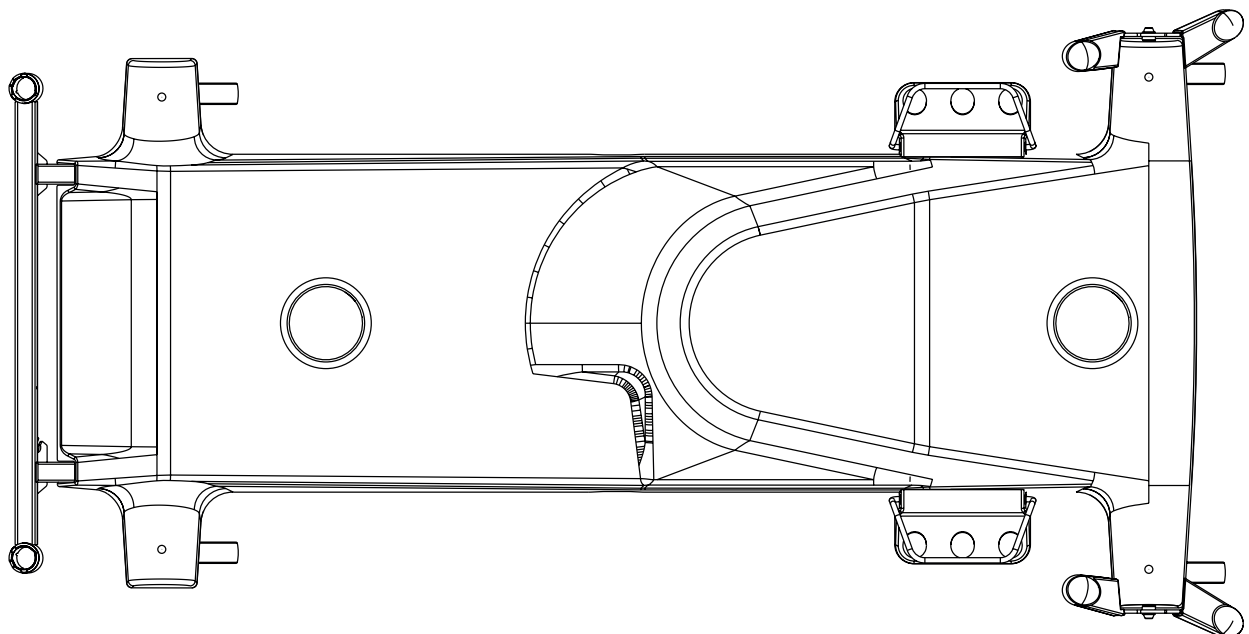

Fig. 1-part undercarriage cover (optional)

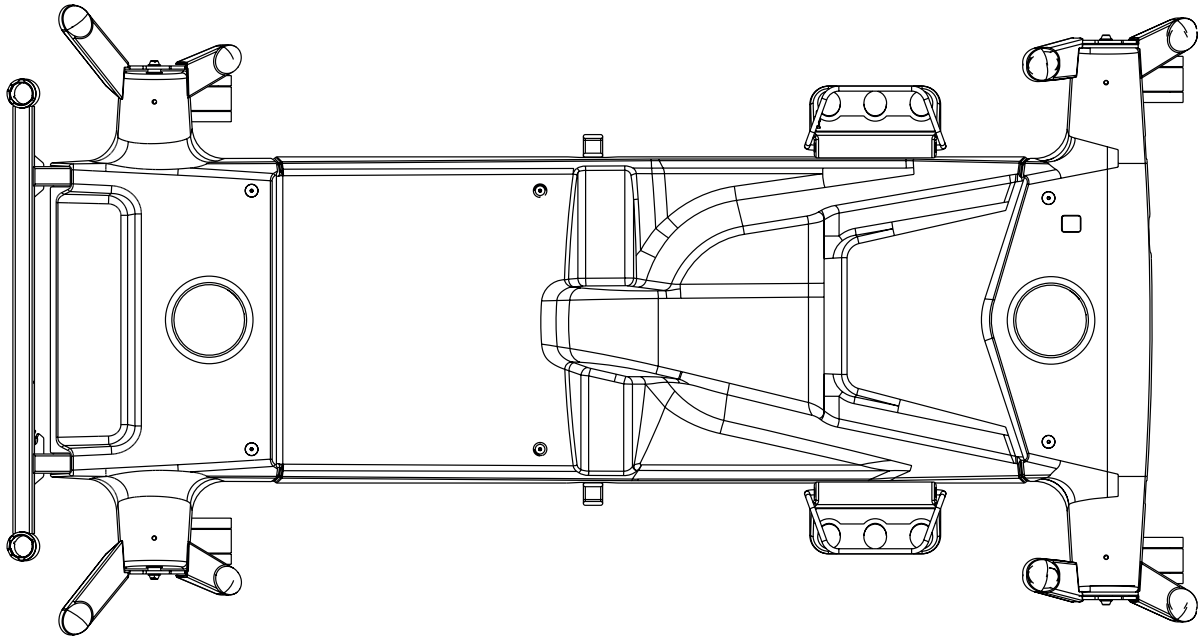

Fig. 3-part undercarriage cover (standard)

14.12 USB Connector (optional)



WARNING!

Risk of injury due to incorrect use!

- ▶ Ensure accessory plugged in USB connector is in pristine condition!
- User of the bed is responsible for the fact that this requirement is met.



CAUTION!

Risk of material damage due to incorrect use!

- ▶ Do not plug heating element into USB connector!
- User of the bed is responsible for the fact that this requirement is met.



CAUTION!

Risk of material damage due to incorrect cleaning!

- ▶ No liquid should get to the USB port!

USB Connector situated on the both sides of Backrest is intended for charging mobile phones and tablets.

NOTE Maximum current for this device is 2 A.



Fig. Fig. USB label with electric specifications

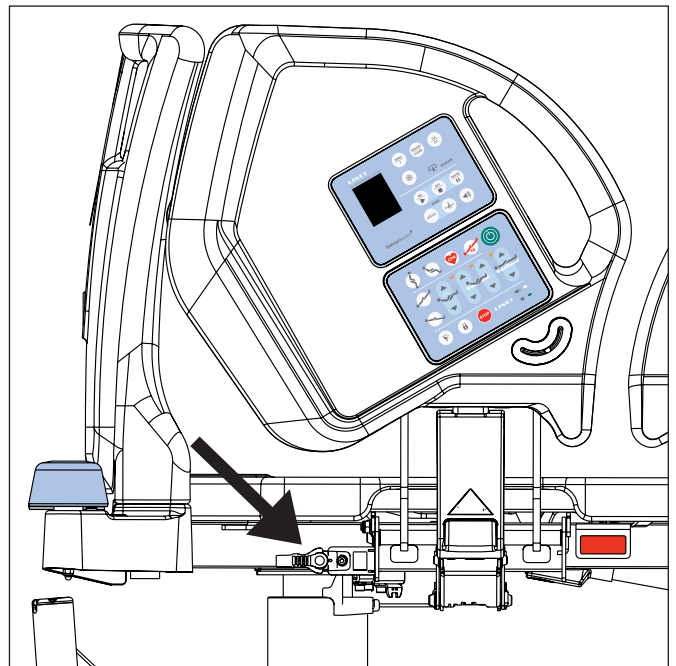

Fig. USB Connector on the side of Backrest

15 Mattress

Eleganza 4 bed is designed for mattresses from LINET portfolio.



CAUTION!

Incompatibility with bed due to incorrect mattress dimensions!

- ▶ Check maximum approved mattress dimensions (chapter Technical Specification of Eleganza 4).

The manufacturer recommends the use of the following mattresses on the Eleganza 4 bed:

PASSIVE MATTRESSES

- CliniCare 10
- CliniCare 20
- CliniCare 30

ACTIVE MATTRESSES

- CliniCare 100 HF
- Air2Care
- Virtuoso

15.1 Installation of Passive Mattress

The passive mattresses intended for Eleganza 4 bed are equipped with straps with buckles (1) to fix mattress on the Mattress Support Platform.

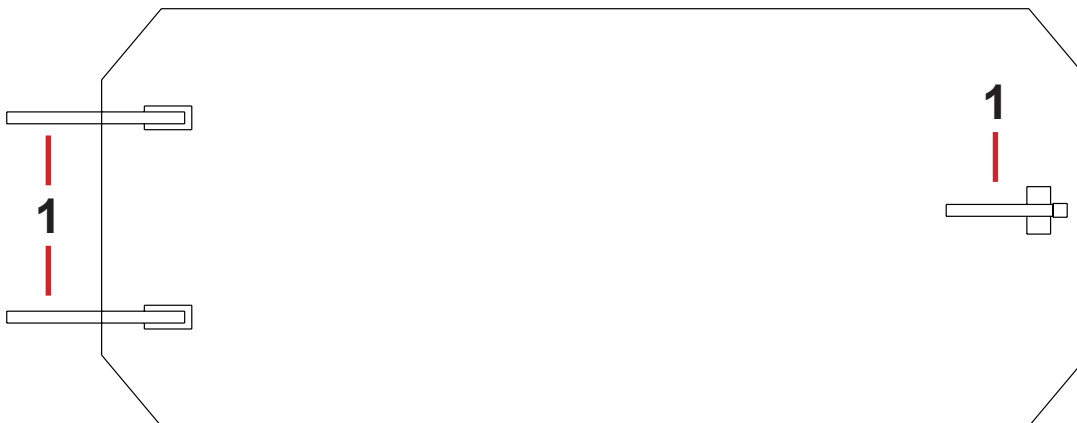

Fig. Bottom of Passive Mattress

15.1.1 Straps with side release buckles

To fix mattress on the Mattress Support Platform:

- ▶ Run three straps through the three corresponding holes in the covers of Mattress Support Platform.
- ▶ Run these three straps under the bars of the Mattress Support Platform.
- ▶ Lock the three side release buckles by connecting their male and female parts together.

To remove mattress from the Mattress Support Platform:

- ▶ Release the three buckles by pressing them from both sides and by disconnecting their male and female parts.
- ▶ Pull these three straps out of the Mattress Support Platform.
- ▶ Remove mattress from the Mattress Support Platform.

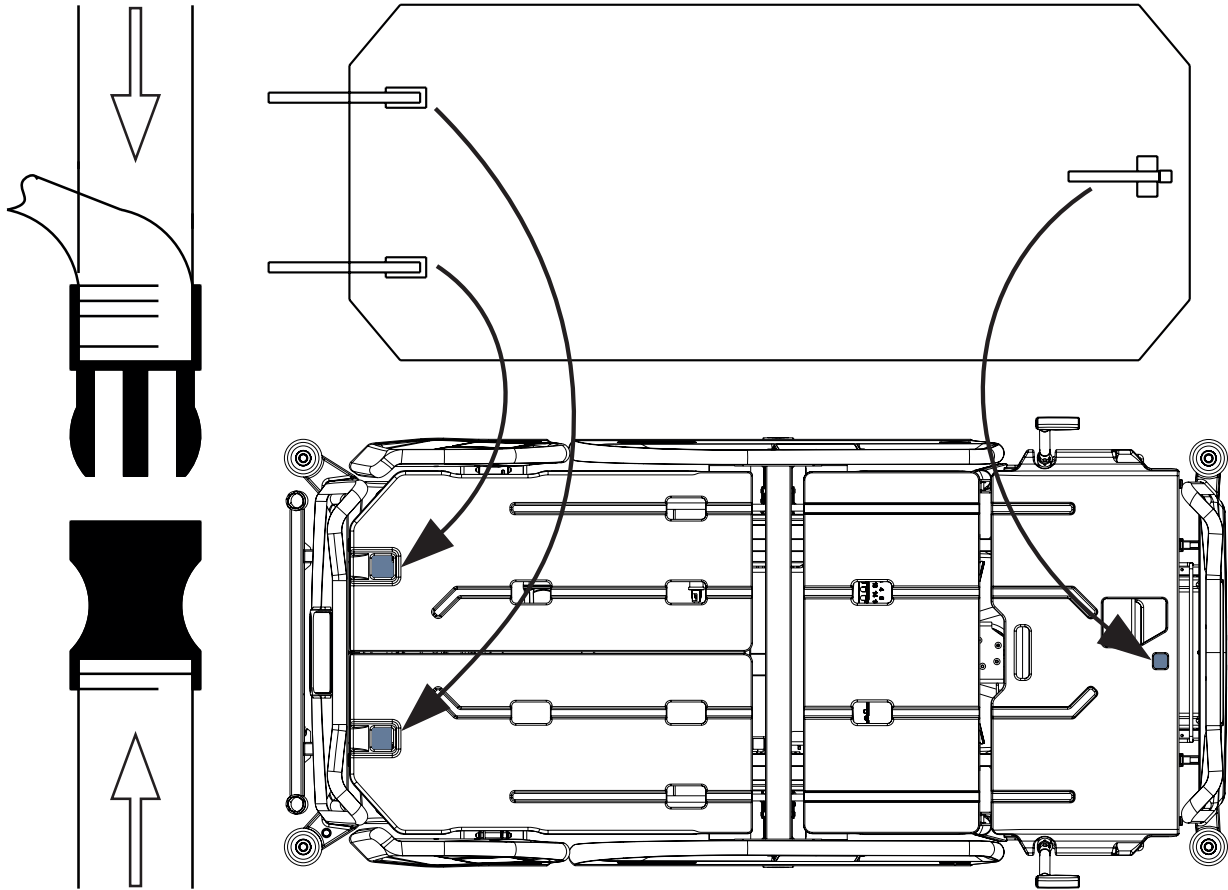

Fig. Fixation of the passive mattress with straps on the mattress support platform of Eleganza 4 bed

15.2 Installation of Active Mattress



WARNING!
Follow instructions for use of a compatible active mattress carefully!



CAUTION!
Risk of material damage due to an incorrect fixation of compatible active mattress on the mattress support platform!
▶ Adjust the bed to maximum Cardiac Chair Position before fixing all the straps of the inflated mattress to the mattress support platform!

Installation instructions:

- ▶ Remove any existing mattress.
- ▶ Observe mattress dimensions and its orientation before putting it on the Mattress support platform.
- ▶ Place SCU on the foot board of the bed or on the floor.

15.2.1 Straps with side release buckles

To fix mattress on the Mattress Support Platform:

- ▶ Inflate the mattress intended to be fixed on the mattress support platform.
- ▶ Adjust the bed to the maximum Cardiac Chair Position.
- ▶ Run four straps through the four corresponding holes in the covers of Mattress Support Platform and two straps through the accessory holders under the calfrest cover.
- ▶ Lock all the side release buckles by connecting their male and female parts together.

To remove mattress from the Mattress Support Platform:

- ▶ Release all the buckles by pressing them from both sides and by disconnecting their male and female parts.
- ▶ Pull all the straps out of the Mattress Support Platform.
- ▶ Remove mattress from the Mattress Support Platform.

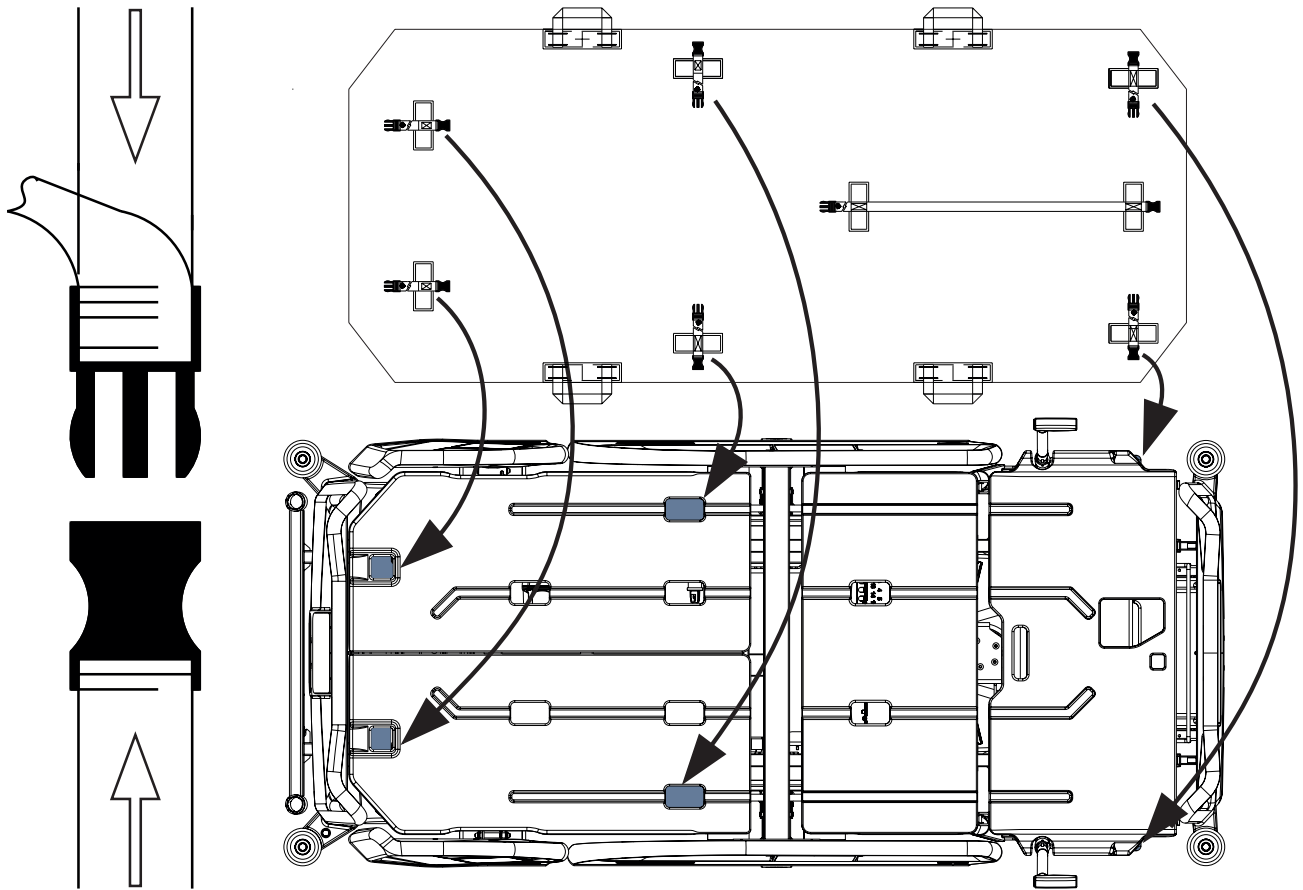

Fig. Fixation of active mattress with straps on the mattress support platform of Eleganza 4 bed

16 Accessories



WARNING!

Risk of injury due to incompatible accessories!

- ▶ Use exclusively original accessories from the manufacturer.
- The manufacturer is not responsible for the use of unapproved accessories.



WARNING!

Risk of injury due to damaged accessories!

- ▶ Use exclusively accessories in perfect condition.



WARNING!

Avoid collisions between accessories and bed parts before use of the accessories!



WARNING!

Risk of injury or material damage due to incorrect use!

- ▶ Compatible accessories manufactured by different manufacturers have their own instructions for use. It is necessary to read instructions for use of a compatible accessory with instructions for use of the compatible LINET product to respect especially technical parameters, warning notifications, cleaning and maintenance instructions of LINET products and their compatible accessories!

Compatible Accessories	Identification Numbers
Lifting pole	11011450A0000, 11011450B0000, 1101145000000
with Triangular holder	4ROTGERSG700-2, 4ROTGNR100GR-2
with Infusion holder	16010700B0000, 16010700A0000, 4MAPL00N1001, 1101030000000
Telescopic Infusion Stand	4PV17744500L, 4PV340290000, 4PV322717000, 4PV17604800L, 4PV17587200L
with Fixation holder	11028700B0000
with Infusion bottle basket	4DR426101
Collapsible Infusion Stand	4MA45MNA0006
Mobile Infusion Stand	4ZZ426100
Writing shelf	11023230B0000
Monitor shelf	11026700B0000
Utility shelf	11025800B0000
Crutches holder	1102070000000
Name holder	4GT006000000
Horizontal oxygen bottle holder	4MAS6015553
Vertical oxygen bottle holder	4MAR2010PC007-1
with Adaptor	11029700A0000
Siderail accessory holder	11028700B1000
Ventilation circuit holder	4MAR2016PC001
Urinary bag holder	11023820B0000
Positioning cushion	4SET17500001
Traction frame E	4MAEXE500000
m-Panel	1MPAS6018146
Pair of Protectors	11005900B0ELE4
Pushing Handles	11022200A0000
Pushing Handles with Holder of the i-Drive Power Control Panel	11022200A0X01

- 1. Lifting pole
- 2. Infusion stand
- 3. Oxygen bottle holder (vertical version)
- 4. Ventilation circuit holder

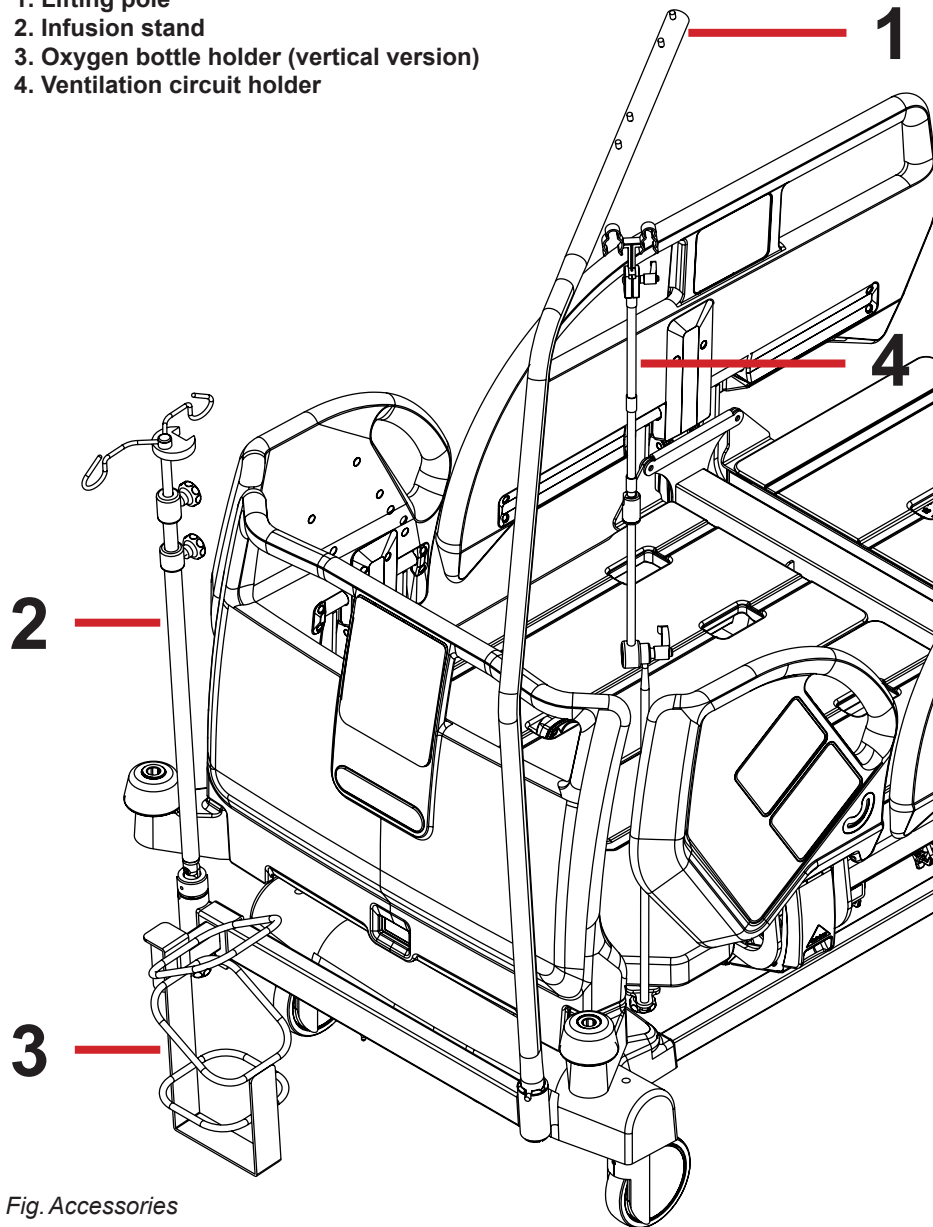

Fig. Accessories

16.1 Lifting Pole



WARNING!

Risk of injury or material damage due to use of the Lifting Pole 11011410B0000 or 11011410A0000 or 1101141000000 with Eleganza 4 bed!

- ▶ Avoid collisions between the Lifting Pole 11011410B0000 or 11011410A0000 or 1101141000000 and the head board of the bed in the Trendelenburg position!

To ensure safe use of the lifting pole:

- ▶ Never exceed the maximum load of 75 kg.
- ▶ Never use the lifting pole for rehabilitation exercises.
- ▶ To prevent the bed from tipping over, ensure that the lifting pole does not project out from the bed.
- ▶ Replace plastic handle every 4 years.

To install the lifting pole:

- ▶ Insert lifting pole in corresponding sleeve fitting on accessory adapter at head end.
- ▶ Ensure that safety pin locks into place.
- ▶ Attach a plastic grab handle with an adjustable strap to the lifting pole.

NOTE The date of manufacture is marked on the grab handle.

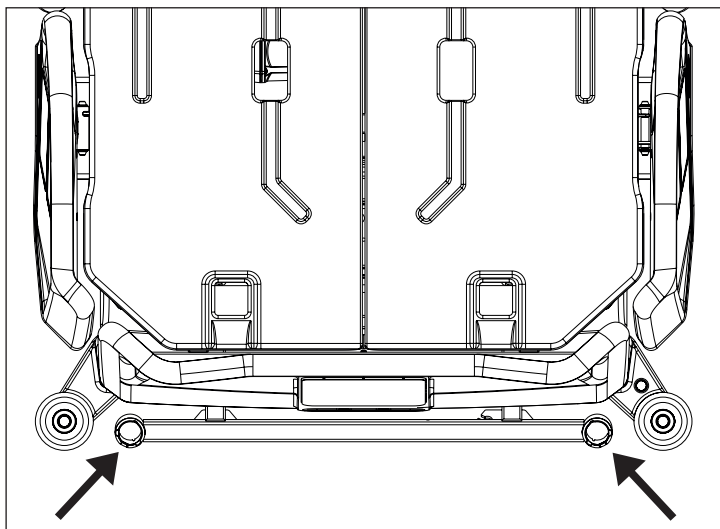

Fig. Places for lifting pole (sleeve fittings on accessory adapter)

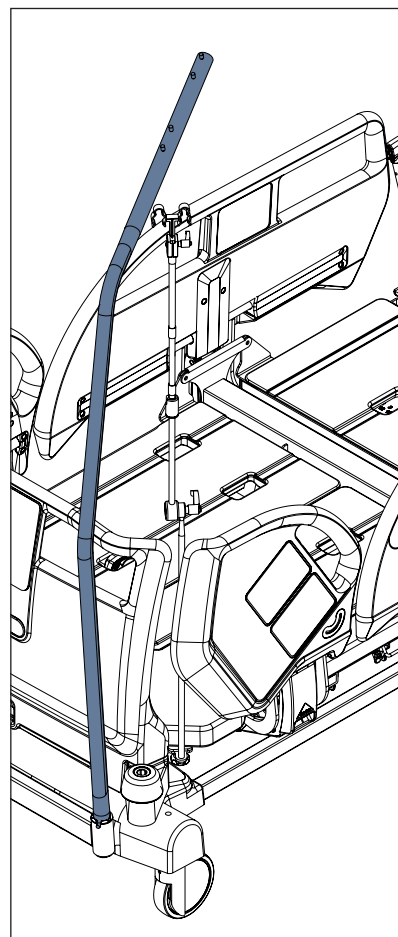

Fig. Lifting pole

16.2 Infusion Stand



WARNING!

Risk of injury due to use of incorrect accessories or because of incorrect use!

Infusion Stands must only be used for their intended use. Always read the instructions for use!

- ▶ Only mount an infusion pump to the lower (wider) telescopic section of an infusion stand above the head/foot board.
- ▶ Never mount an infusion pump to the upper (thinner) telescopic section of an infusion stand.
- ▶ Ensure the infusion pump will not collide with any movable parts of the bed (especially Backrest part) or with the patient. This must be verified during installation.
- ▶ Do not over tighten the infusion pump clamps during fitment. Over tightening may damage the infusion stand.
- ▶ Infusion pump can be only used if the infusion stand is fitted in the accessory holder socket in the head end on the under carriage of the bed.
- ▶ Do not use the infusion stand as driving/pushing device during the bed transport.



CAUTION!

Risk of collision with oxygen bottle holder on the bed end due to incompatibility!

- ▶ Use the foldable infusion stand with adapter to avoid the collision.

Infusion stands are intended to provide a suitable support for the attachment of the infusion pumps/syringe pumps and suspension of the infusion bags or bottles.

Infusion stands can be fitted to the head and foot end of the bed by either fitting into the IV/Infusion sockets mounted on the bed or using alternative accessory holder socket in the head end on the undercarriage of the bed.

- ▶ Use exclusively infusion stands with hooks for hanging IV bags or baskets for intravenous solutions.
- ▶ Ensure the infusion stand individual hook 2kg maximum Safe Working Load is not exceeded.
- ▶ Ensure the infusion stand maximum Safe Working Load is not exceeded.
- ▶ Follow the actual price list for information about types of infusion stands.

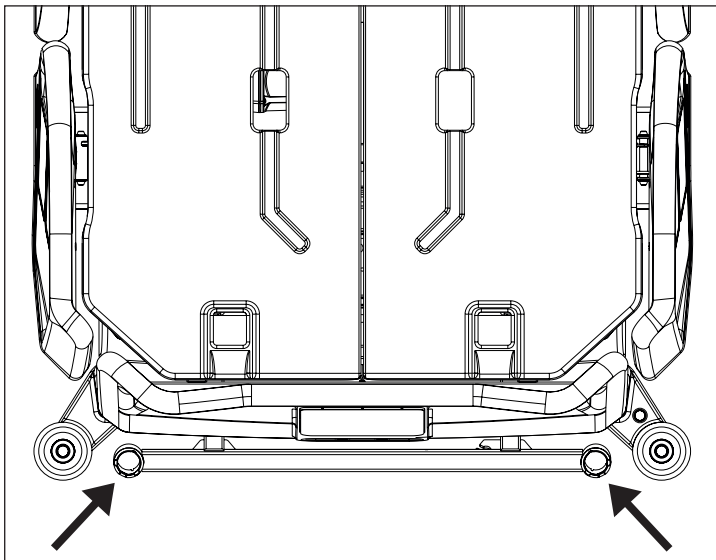

Fig. Places for infusion stand (sleeve fittings on accessory adapter)

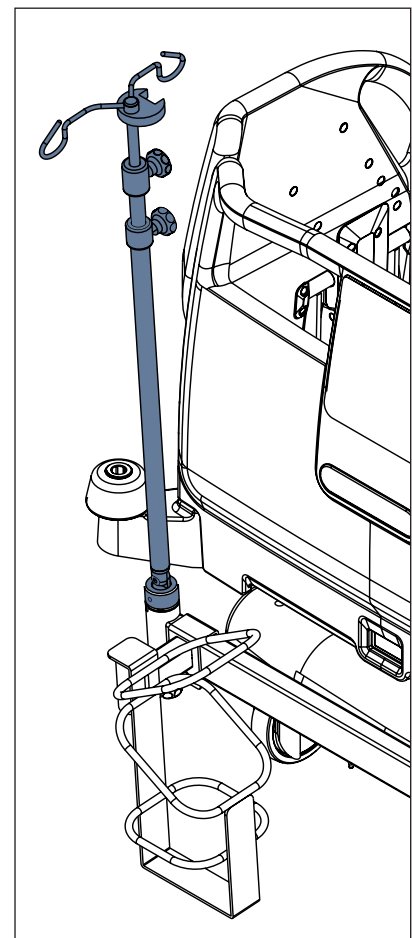

Fig. Infusion stand

16.3 Oxygen Bottle Holder



WARNING!

Risk of injury with oxygen bottle holder due to incorrect use or due to careless driving!

- ▶ Ensure the oxygen bottle holder is correctly fitted in correct position.
- ▶ It is necessary to place oxygen bottle holder (with or without oxygen bottle) before transport to secure transport position.
- ▶ Be aware of people or objects in close proximity when driving or manipulating the bed equipped with oxygen bottle holder.
- ▶ Secure the oxygen bottles against falling or involuntary movement with rubber strap.
- ▶ Place the oxygen bottle holder on the bed by instructions in the following text.
- ▶ Ensure the oxygen bottle valve will not get damaged by careless or incorrect manipulation or placement.

The oxygen bottle holders are suitable for transporting oxygen bottles with a weight of up to 15 kg and a volume of 5 litres.

Horizontal version (Head End)

- ▶ Put oxygen bottle holder on crossbar on the head end of the bed.

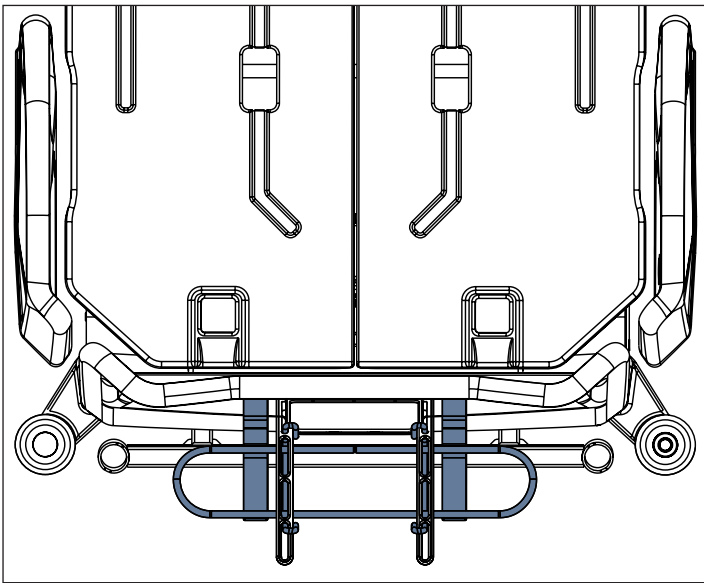

Fig. Oxygen Bottle Holder (on the head end)

Vertical version (with adapter)

On following pictures there are 4 positions of the oxygen bottle holder with adapter.

- ▶ Put holder on sleeve fittings in multifunctional accessory adapter on head end.
- ▶ Ensure the locking pin of vertical oxygen bottle holder is locked in sleeve fitting.

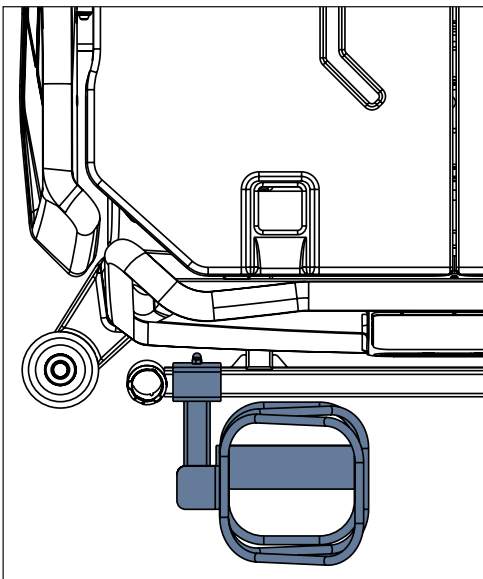

Fig. Oxygen Bottle Holder in the adapter (position 1)

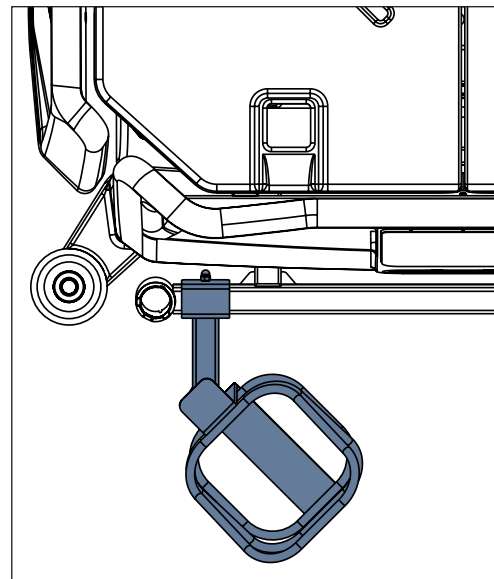

Fig. Oxygen Bottle Holder in the adapter (position 2)

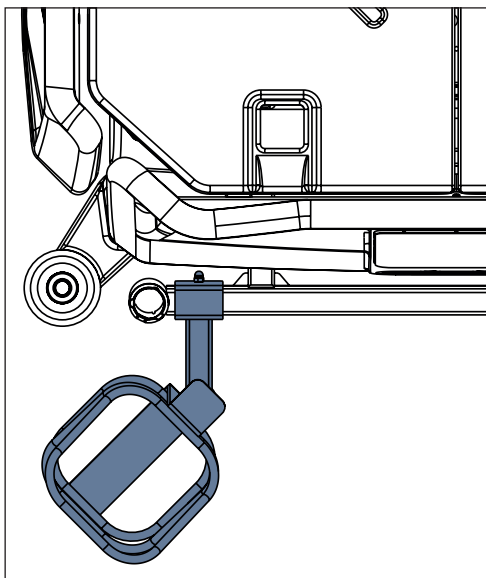

Fig. Oxygen Bottle Holder in the adapter (position 3)

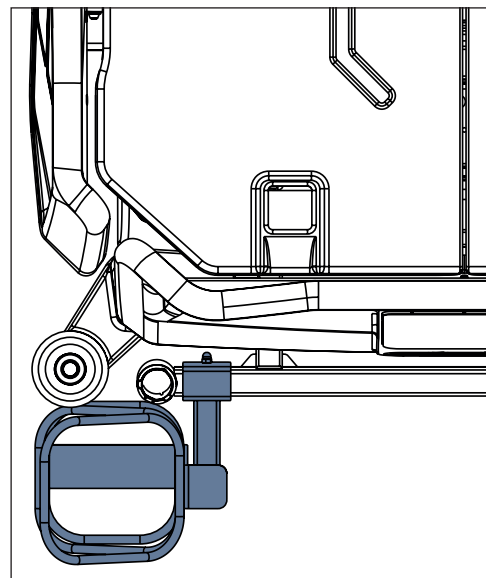

Fig. Oxygen Bottle Holder in the adapter (position 4)

16.4 Ventilation Circuit Holder

The ventilation circuit holder prevents extubation of the patient connected to the ventilator.

- ▶ Always use LINET® ventilation circuit holder to prevent extubation during any procedures.

Applying ventilation circuit holder:

- ▶ Put ventilation circuit holder in hole on right or left side of the Backrest frame.
- ▶ Fasten ventilation circuit holder with wing screw provided.
- ▶ Put intubation tube through plastic head of ventilation circuit holder.
- ▶ Tilt mattress support platform left and right by 15° to check if intubation tube is fastened securely. The fastening is secure if no parts of the ventilation circuit are disconnected.

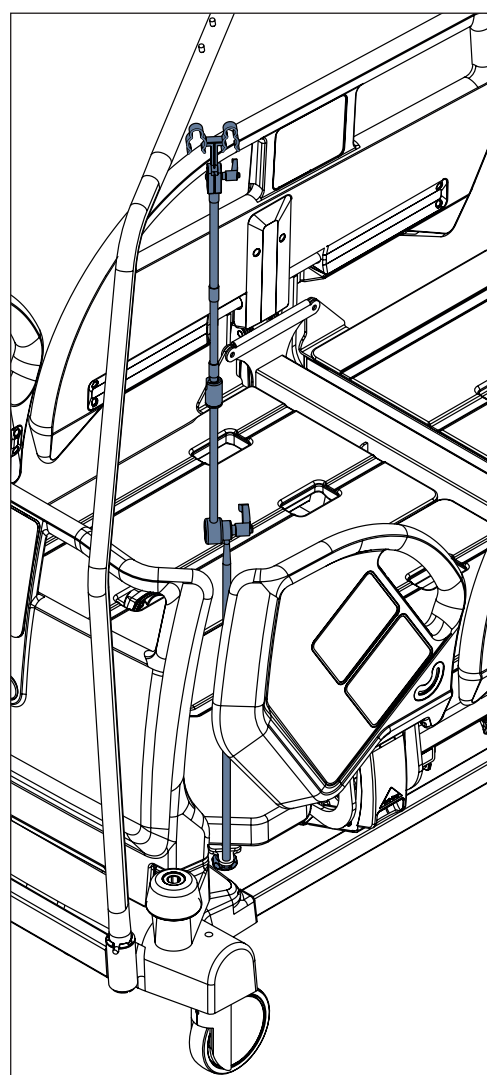

Fig. Ventilation Circuit Holder

16.5 Writing Shelf

The Writing Shelf is intended for writing of nursing staff.
It is placed in the handles of the foot board (as on the picture).

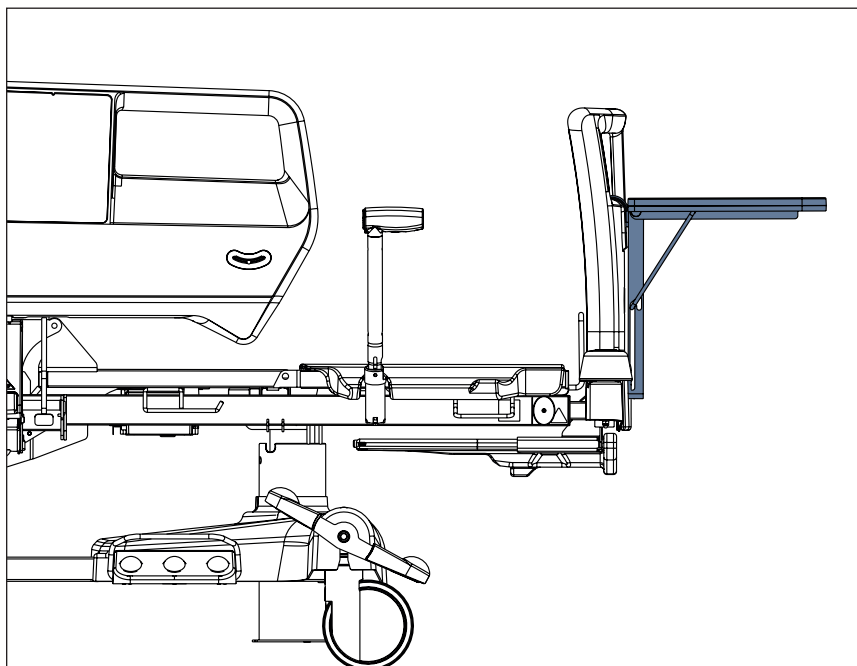

Fig. Writing Shelf

16.6 Monitor Shelf

The Monitor Shelf is suitable for transporting monitors with a weight of up to 15 kg.

Installing the Monitor Shelf:

- ▶ Place Monitor Shelf on the foot board (as on the picture).
- ▶ Fix the monitor with safety belts in order to avoid any damage during transport.

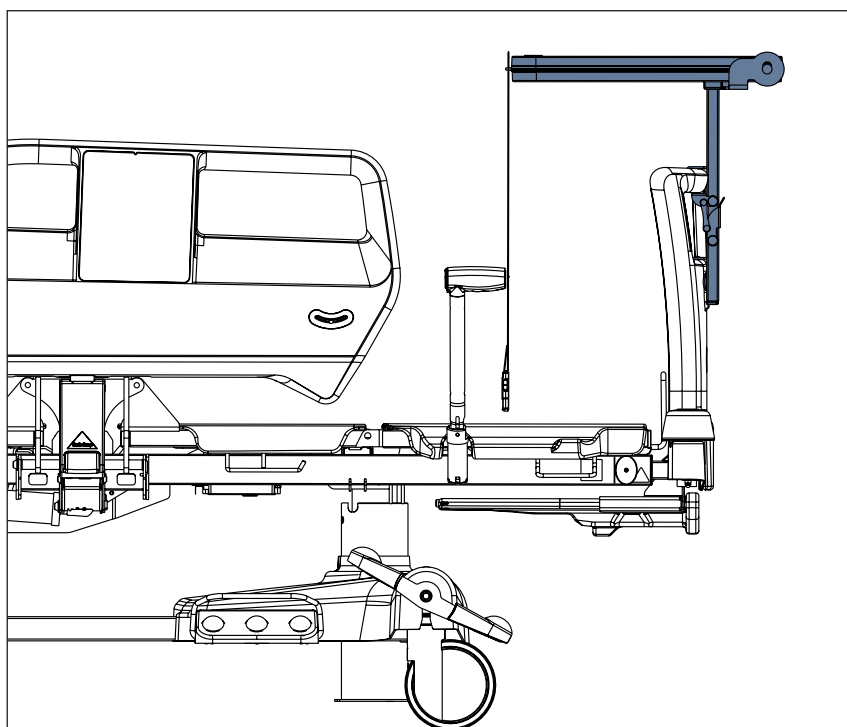

Fig. Monitor Shelf

16.7 Urinary Bag Holder

Urinary Bag Holders are available on both sides of the bed at Backrest area.

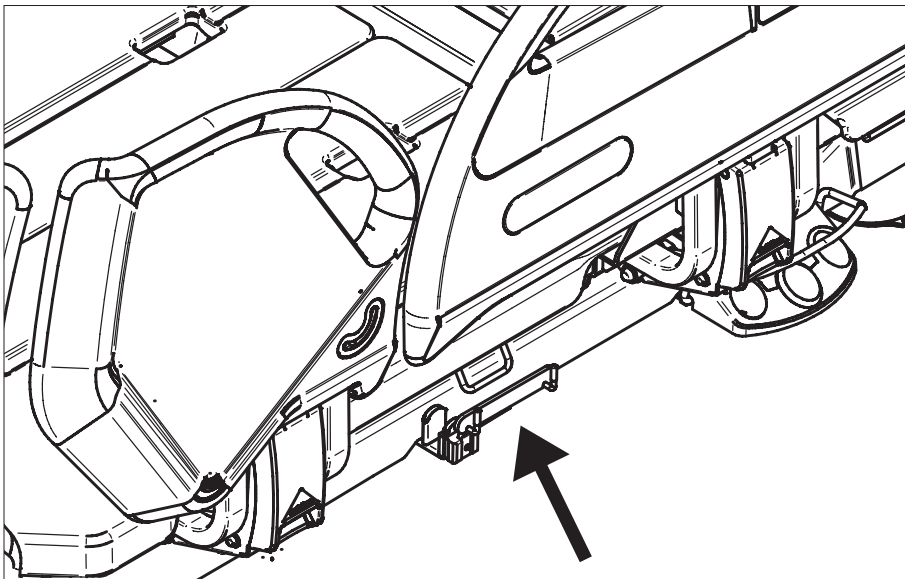

Fig. Urinary Bag Holder

16.8 Protectors



WARNING!

Risk of injury due to the patient falling off the bed!

- ▶ Ensure that the Protector is installed securely.
- ▶ Always check that the siderails are properly locked in the „up“ position.
- ▶ Make sure the fall risk assessment was done properly before use of the Protectors.
- ▶ For use of the Eleganza 4 bed with Protectors, it is recommended to disable the Backrest and Thighrest Adjustment functions of the Patient Control Panels located on the inner sides of the foot siderails via Attendant Control Panel or Nurse Control Panel to reduce the risk of patient fall to the minimum level.



CAUTION!

Right Protector and left Protector are not interchangeable! Ensure the both Protectors are properly installed on the bed!



CAUTION!

Follow the wash symbols on the label of Protector cover to clean the Protector cover correctly!

Intended Use

Two Protectors are an optional accessory for the Eleganza 4 bed. The Protectors can only be installed on the Eleganza 4 bed ready for Protectors. This bed configuration includes the casings for Protectors on both sides of the bed at foot end. Without this bed configuration, an intervention of a qualified and trained service technician is necessary to enable the use of the Eleganza 4 bed with Protectors. The main purpose of the Protectors is to reduce the risk of fall at very risky patients (confused restless patients). The use of the Protectors for the other patients is not necessary. The Protectors can be used with standard or extended mattress support platform.

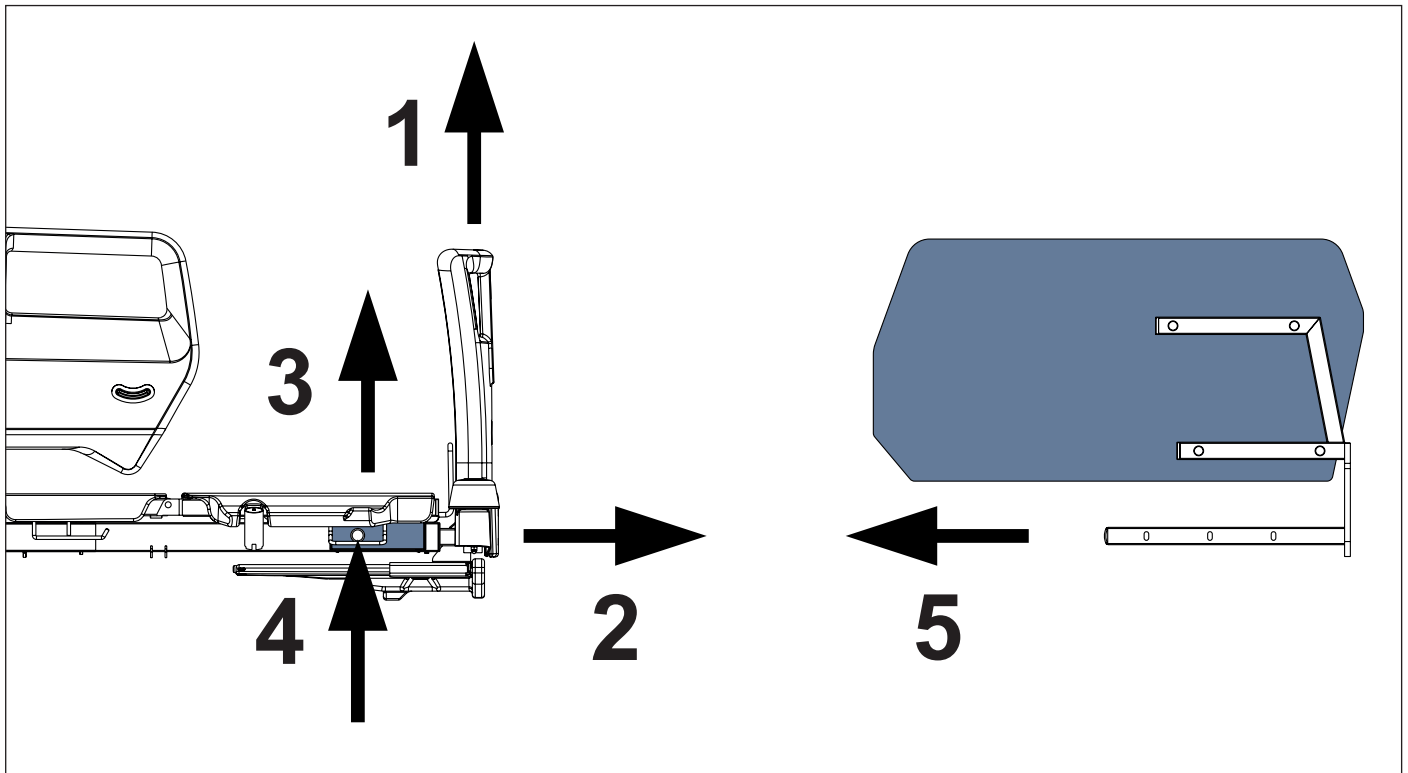

Fig. Protector placement at the right foot end of the Eleganza 4 bed

Placement

Attach the Protector to the bed as follows:

- ▶ Remove the Foot Board (1).
- ▶ Extend the Mattress Support Platform as needed (2).
- ▶ Lift the Calfrest up (3).
- ▶ Turn the safety catch (4) to ensure the casing for the Protector is opened.
- ▶ Insert the Protector to the casing at foot end of the bed with regard to the required Mattress Support Platform extension (5).
- ▶ Turn the safety catch back to ensure the casing for the Protector is closed in required position.
- ▶ Lower the Calfrest down.
- ▶ Reduce the Mattress Support Platform extension as needed.
- ▶ Insert the Foot Board back to the foot end of the bed.

Remove the Protector from the bed as follows:

- ▶ Remove the Foot Board (1).
- ▶ Extend the Mattress Support Platform as needed (2).
- ▶ Lift the Calfrest up (3).
- ▶ Turn the safety catch (4) to ensure the casing for the Protector is opened.
- ▶ Remove the Protector from the casing at foot end of the bed.
- ▶ Lower the Calfrest down.
- ▶ Reduce the Mattress Support Platform extension as needed.
- ▶ Insert the Foot Board back to the foot end of the bed.

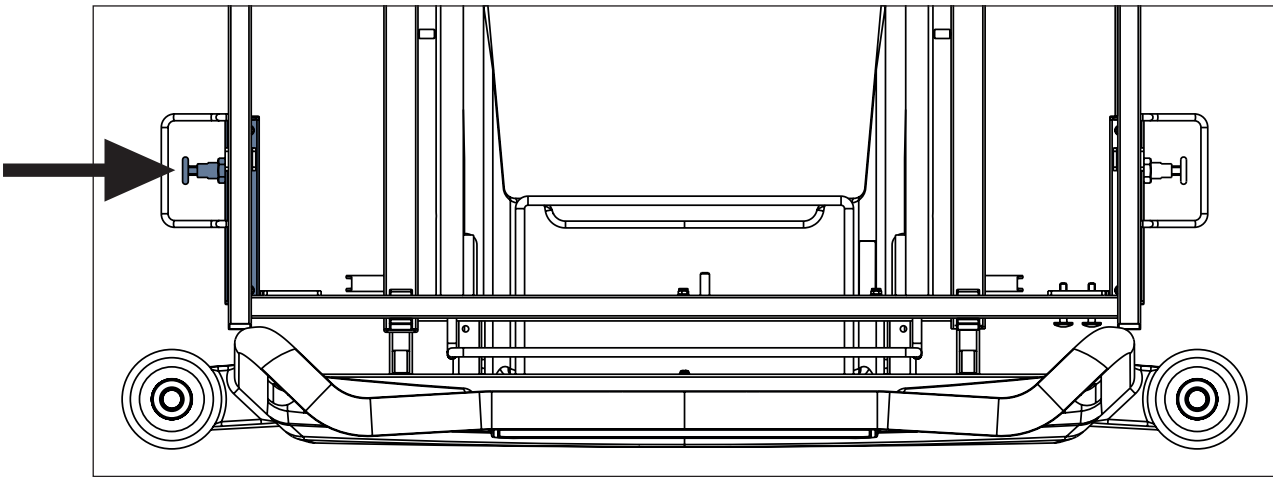

Fig. Position of the right safety catch for fixing the right Protector

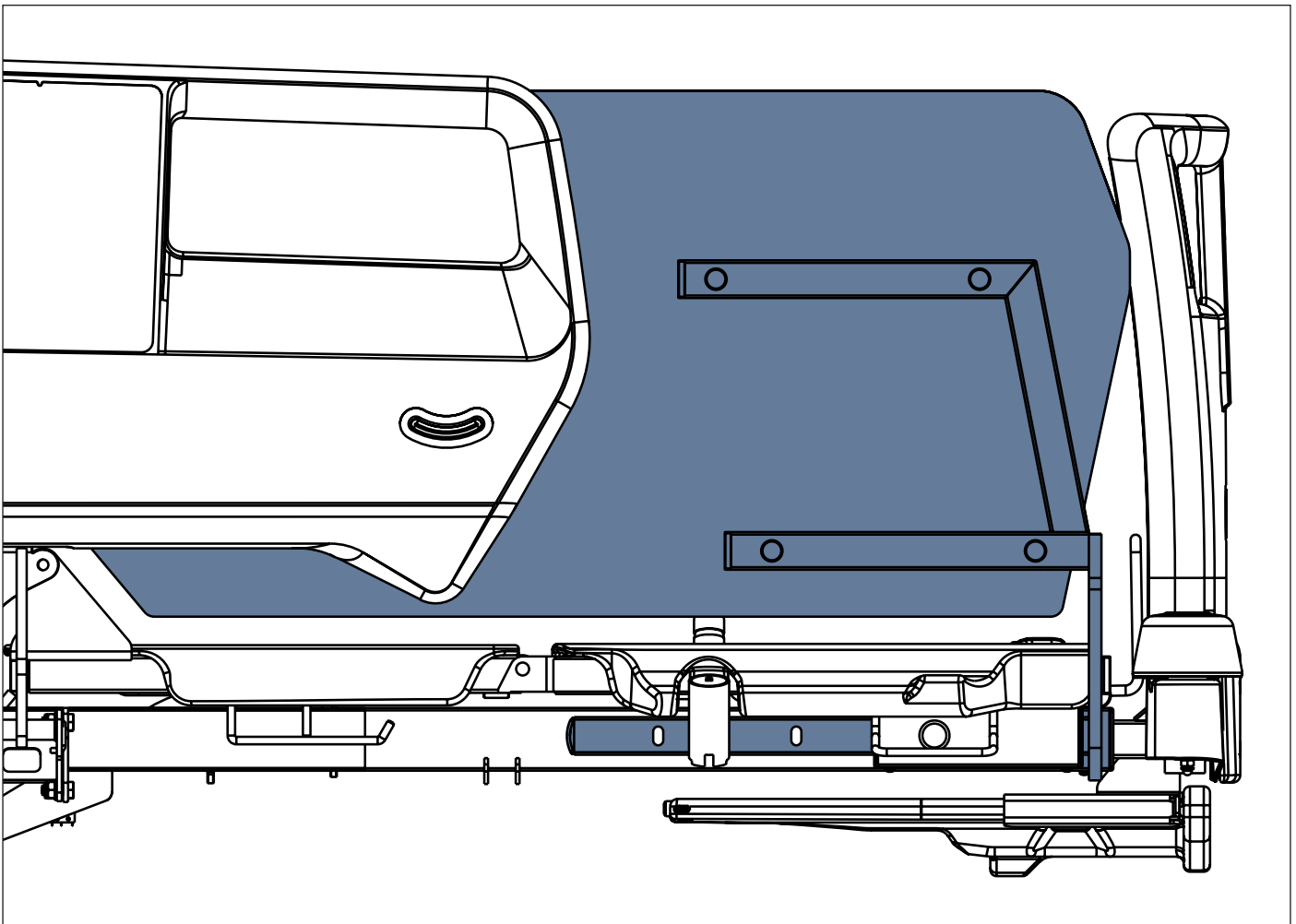

Fig. Protector correctly installed at the right foot end of the Eleganza 4 bed

16.9 SafetyMonitor



WARNING!

Read the instructions for use for SafetyMonitor carefully before use of the Eleganza 4 bed with SafetyMonitor!

Intended Use

SafetyMonitor is a system that monitors statuses of Eleganza 4 bed: brake status (braked castors/unbraked castors), siderail status (siderails up/siderail down), bed height (bed in the lowest position/bed not in the lowest position), backrest angle (backrest in more than 30°/backrest in less than 30°), patient presence (patient on the bed/patient not on the bed) and location of the bed (where the bed is situated). Secure statuses are: braked bed, siderails up and locked, bed in the lowest position, backrest in more than 30° and patient on the bed. The system triggers alerts (notice signals for insecure statuses) and alarms (alarm signals for the absence of a patient on the bed). Alerts and alarms are automatically passed to the hospital information system and displayed on a screen in the nurse station and on a smartphone/tablet. Information is transmitted via LAN or Wi-Fi connection. Alarm (Bed Exit Alarm) sounds just from the bed. In this way, medical staff can be informed in a timely manner of any safety risk while saving administrative time.

System components

SafetyMonitor system consists of installed server, secure intranet infrastructure (Wi-Fi or LAN), screen in the nurse station (PC or tablet or smartphone), Tag on the wall, parked Eleganza 4 EMR ready bed with iBoard Basic, Integration Module, Localisation Receiver, LAN connector and LAN cable.

iBoard Basic (SafetyMonitor Section)

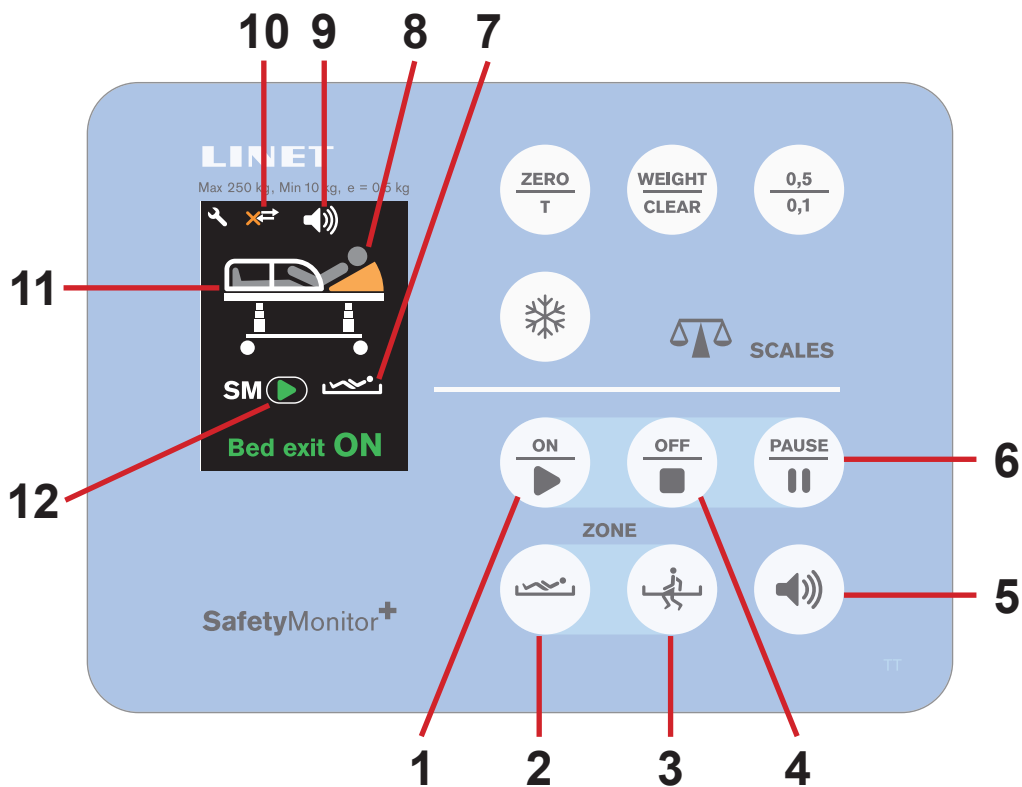
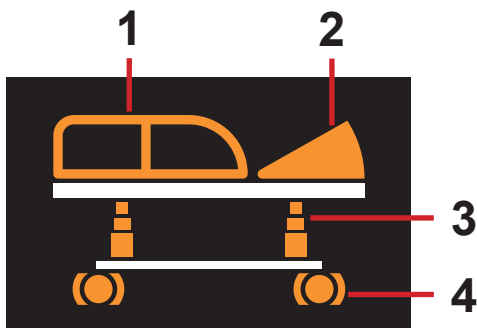

Fig. SafetyMonitor Section (iBoard Basic) - Display and Keyboard

1. ON button (RUN)
2. Inner Zone button (Bed Exit Monitoring)
3. Outer Zone button (Bed Exit Monitoring)
4. OFF button
5. Volume button (3 levels of sound pressure)
6. PAUSE button
7. Bed Exit Monitoring Activated (Inner Zone Monitoring)
8. Patient icon (patient is on the bed)
9. Volume indicator (3 levels of sound pressure)
10. Server connection icon (arrows only – connected, arrows with cross – disconnected)
11. Bed icon with bed statuses
12. SafetyMonitor system status indicator (ON/OFF/PAUSE)



1. siderail status (orange - siderail down)
2. backrest angle (orange - backrest in less than 30°)
3. bed height (orange - bed not in the lowest position)
4. brake status (orange - unbraked castors)

Fig. Bed icon with bed statuses
(orange - alerts/insecure statuses)

16.10 Traction Frame E



WARNING!

Risk of injury due to incorrect use!

- ▶ There must be no patient on the bed when installing the Traction Frame E!
- ▶ Avoid collisions between the Traction Frame E and the bed (Foot Board, Backrest) during bed positioning!
- ▶ Avoid collisions between the Traction Frame E and accessories!
- ▶ Cross the thresholds with caution during transporting the bed with installed Traction Frame E!
- ▶ It is allowed to transport a patient on the bed with Traction Frame E just in emergency cases and with caution!
- ▶ Respect the Safe Working Load of the bed, of the Traction Frame E and of its hooks and pulleys!
- ▶ Remove the Traction Frame E from the bed if it is not needed for treatment!

Intended Use

Traction Frame E is a supporting construction intended for fixation, traction and relief of limbs, spine and pelvis. Traction Frame E is intended for orthopaedic department, surgery department, traumatologic department and for ICU.

Placement

Traction Frame E is inserted to the holes in the Accessory Adaptor at head end and to the holes in the Traction Frame Holder at foot end.

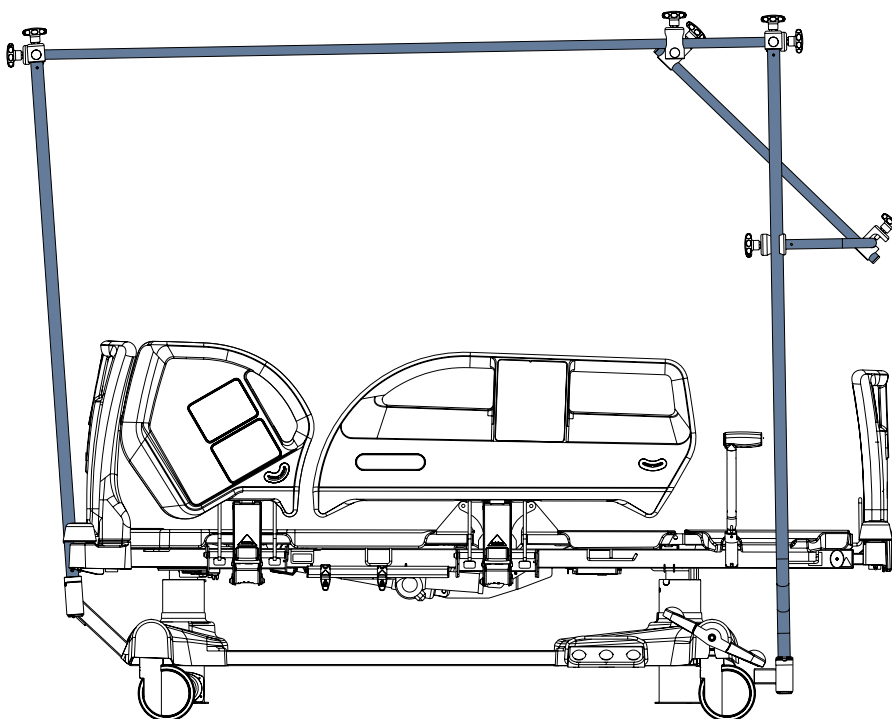

Fig. Eleganza 4 with Traction Frame E (side view)

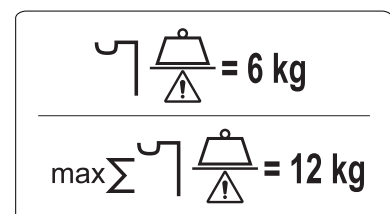

Fig. Safe Working Load of the hooks
(Infusion Holder)

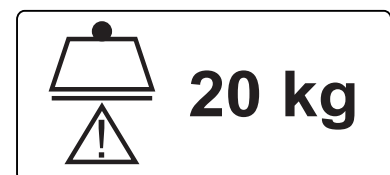

Fig. Safe Working Load of the pulley

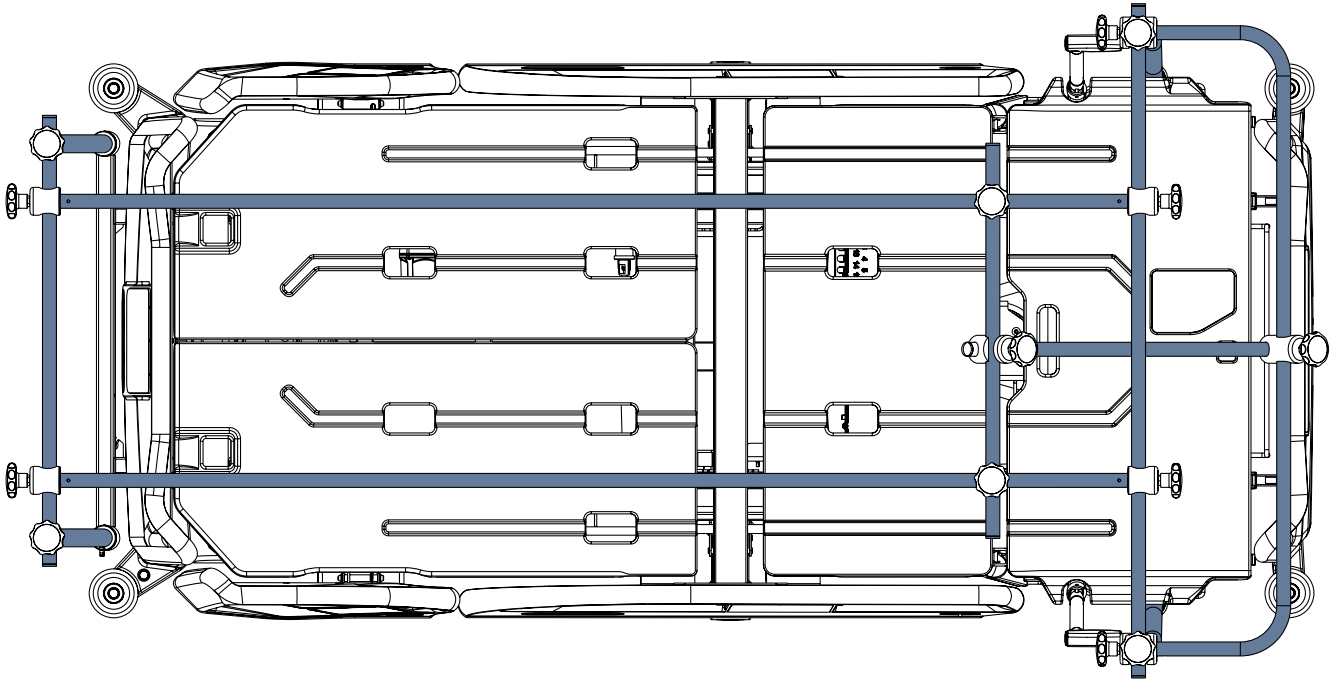

Fig. Eleganza 4 with Traction Frame E (top view)

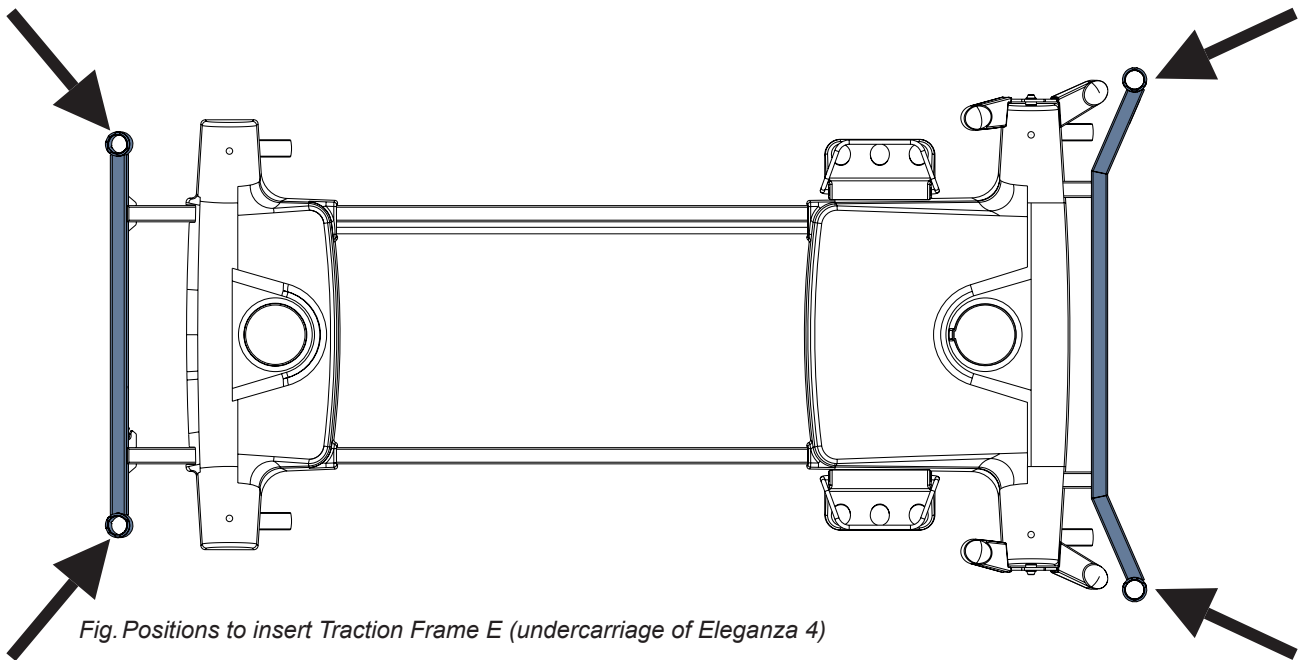

Fig. Positions to insert Traction Frame E (undercarriage of Eleganza 4)

16.11 Pushing Handles



WARNING!

Pushing handles are not compatible with i-Drive Power system!

- ▶ Do not use the pushing handles on the bed that is equipped with i-Drive Power system!



CAUTION!

Follow these instructions during placement of the pushing handles on the head end crossbar:

- ▶ Placement of the pushing handles must be performed by hospital technician according to these instructions for use!
- ▶ Pushing handles can only be placed on the head end crossbar!
- ▶ Positions of the pushing handles are shown on the picture below!
- ▶ Distance between bushing holder and the bar that is at right angle to the head end crossbar is 12 mm.
- ▶ Nuts of bolts must be oriented inwards!

**Pair of Pushing Handles is intended for bed transport.
Pushing Handles are not compatible with head board.
Pushing Handles are located on the head end crossbar.**

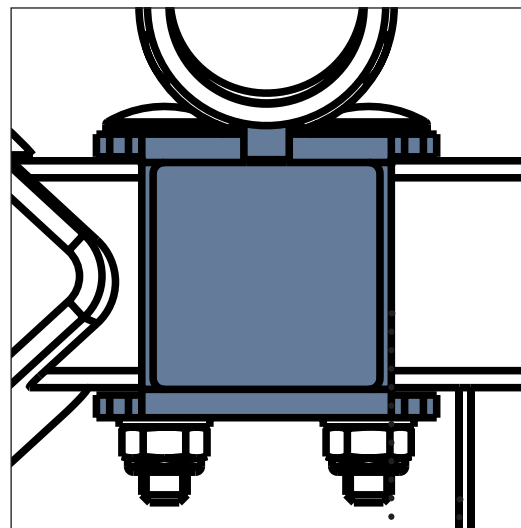

12 mm

Fig. Distance between bushing holder and the bar that is at right angle to the head end crossbar

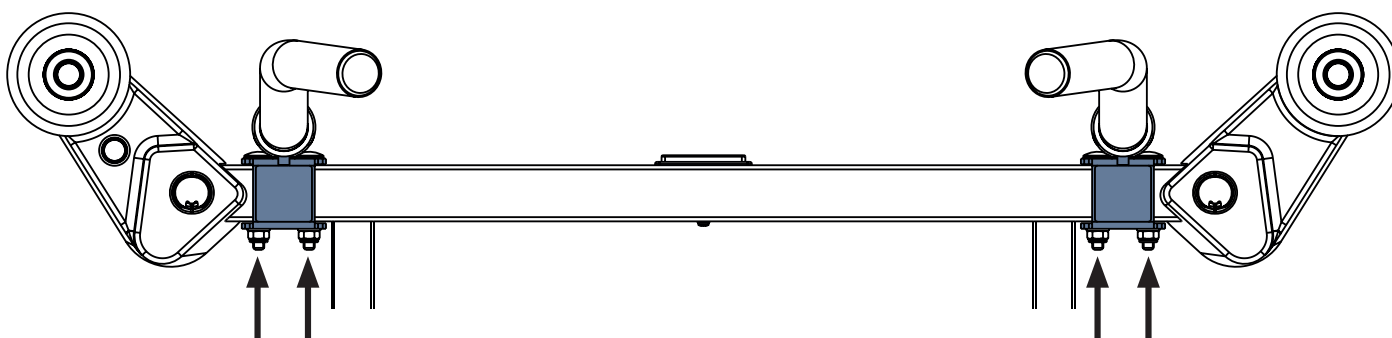

Fig. Placement of pushing handles on the head end crossbar (positions of nuts)

Removal of the Pushing Handles from the bushings:

- ▶ Pull both Pushing Handles out of the fixed bushings on the head end crossbar.

Insertion of the Pushing Handles to their fixed bushings:

- ▶ Insert both Pushing Handles to their fixed bushings on the head end crossbar.

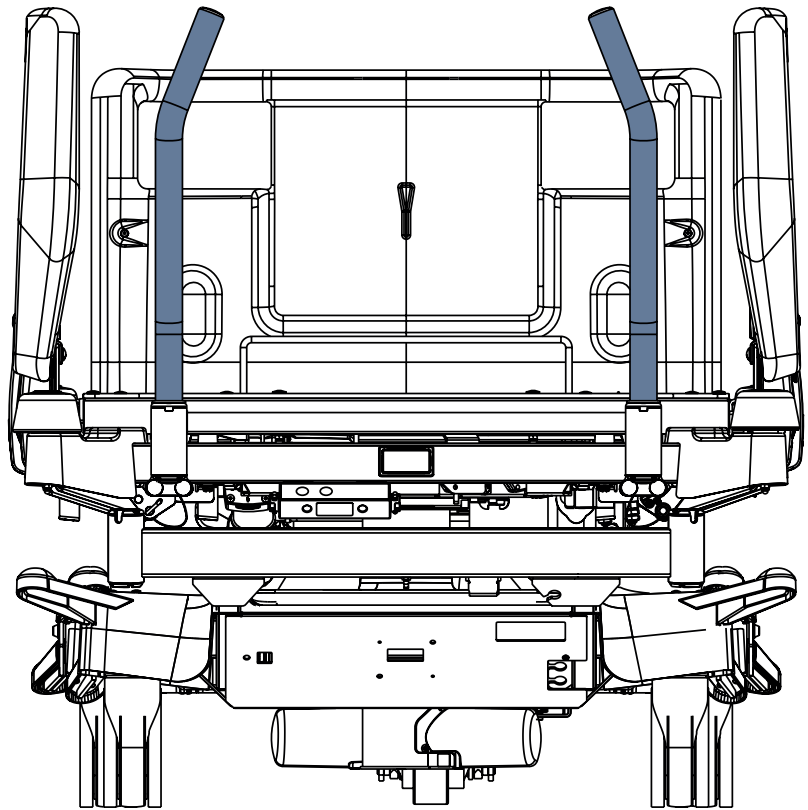

Fig. Pushing Handles on the Eleganza 4 bed

16.12 Pushing Handles with Holder of the i-Drive Power Control Panel



CAUTION!

Follow these instructions during placement of the Pushing Handles with Holder of the i-Drive Power Control Panel on the head end crossbar:

- ▶ Placement of the pushing handles must be performed by hospital technician according to these instructions for use!
- ▶ Pushing handles can only be placed on the bed head end crossbar!
- ▶ Positions of the pushing handles are shown on the picture below!
- ▶ Distance between bushing holder and the bar that is at right angle to the head end crossbar is 12 mm.
- ▶ Nuts of bolts must be oriented inwards!

Pair of Pushing Handles with Holder of the i-Drive Power Control Panel is intended for bed transport.

Pushing Handles with Holder of the i-Drive Power Control Panel are not compatible with bed head board.

Pushing Handles with Holder of the i-Drive Power Control Panel are located on the head end crossbar.

Pushing Handles with Holder of the i-Drive Power Control Panel are compatible with i-Drive Power system. i-Drive Power Control Panel is intended to be placed on the Holder of the i-Drive Power Control Panel.

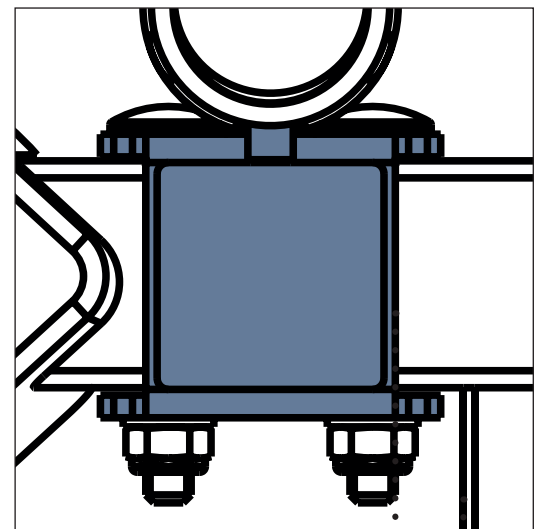

12 mm

Fig. Distance between bushing holder and the bar that is at right angle to the head end crossbar

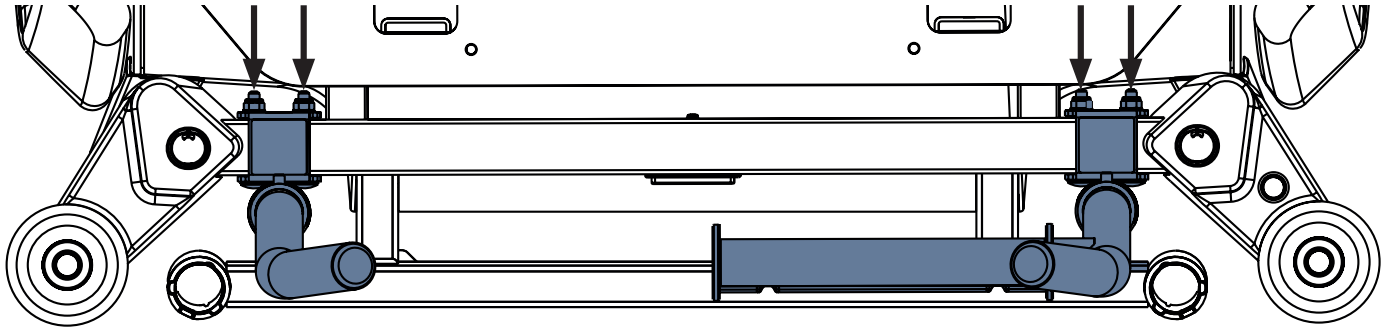

Fig. Placement of pushing handles on the head end crossbar (positions of nuts)

Removal of the Pushing Handles from the bushings:

- ▶ Pull both Pushing Handles out of the fixed bushings on the head end crossbar.

Insertion of the Pushing Handles to their fixed bushings:

- ▶ Insert both Pushing Handles to their fixed bushings on the head end crossbar.

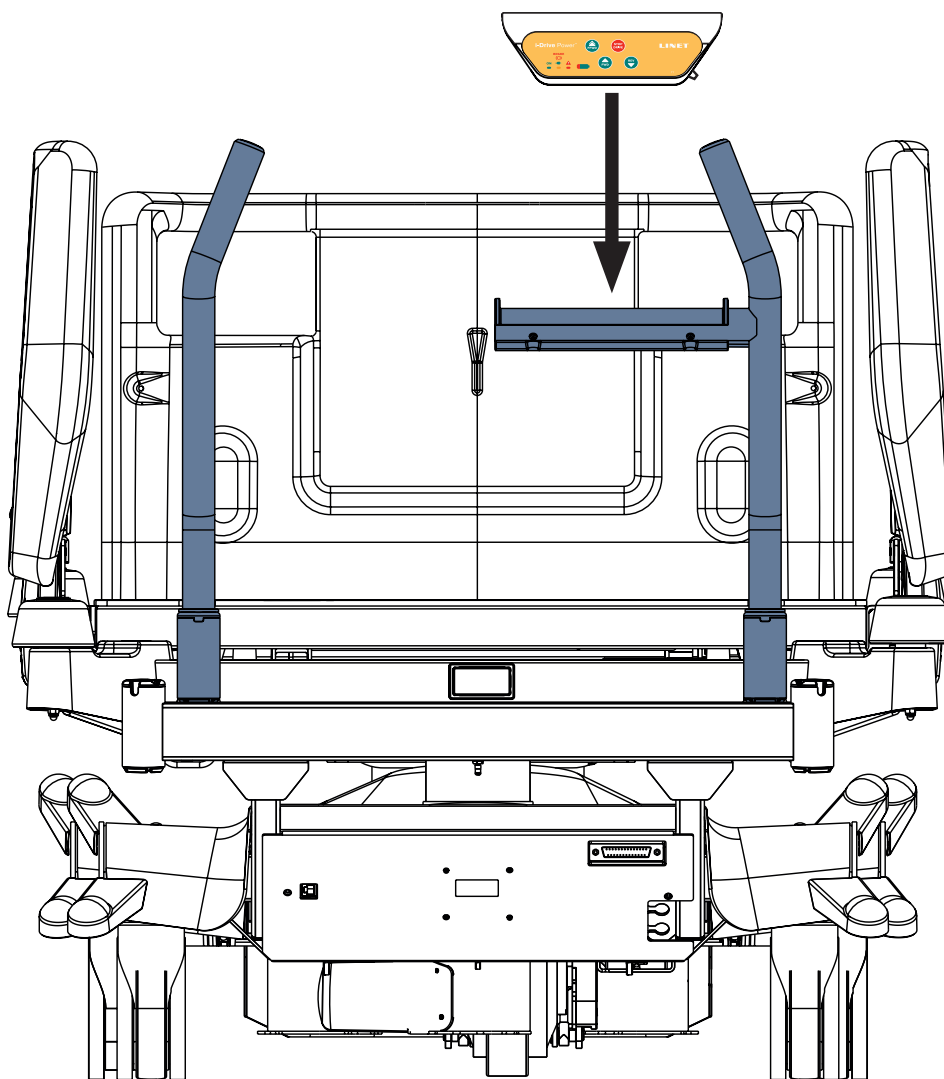

Fig. Pushing Handles with Holder of the i-Drive Power Control Panel on the Eleganza 4 bed

16.13 IDock (size S and size M)



WARNING!

Risk of injury or material damage due to incorrect use!

- ▶ Read Instructions for use of the IDock docking-cart before use of this product!
- ▶ Ensure the safe working load of the IDock docking-cart is not exceeded!



CAUTION!

Risk of collision due to incompatibility!

- ▶ Ensure the selected type of IDock is compatible with the bed undercarriage!
- ▶ IDock is not compatible with any active mattress control unit placed on the Foot Board!



CAUTION!

Risk of injury or material damage due to incorrect installation!

- ▶ The hospital personnel has to ensure the secure mounting of devices on the IDock and of the IDock on the bed!

IDock is intended to transport medical devices and oxygen bottles.

IDock is compatible with Multicare X bed, Multicare bed, Eleganza 5 bed and Eleganza 4 bed.

IDock size S and IDock size M are 2 types of the IDock docking-cart.

IDock must be connected with Foot Board via 2 hooks. If IDock is equipped with Transport Bracket (WDE2903860000) installed on the Foot Board of Multicare X bed or Multicare bed, IDock should be connected with the Transport Bracket via 2 hooks instead.

Installation of the Transport Bracket (only for Multicare X and Multicare)



WARNING!

Ensure the Transport Bracket is correctly installed on the bed foot end crossbar before connecting IDock to the Transport Bracket!

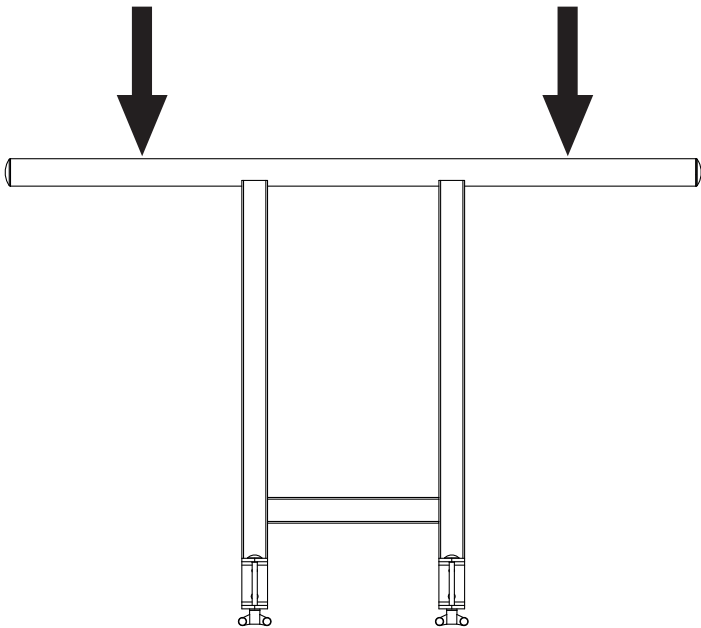

Fig. Positions for IDock hooks on the Transport Bracket



Fig. IDock docking-cart

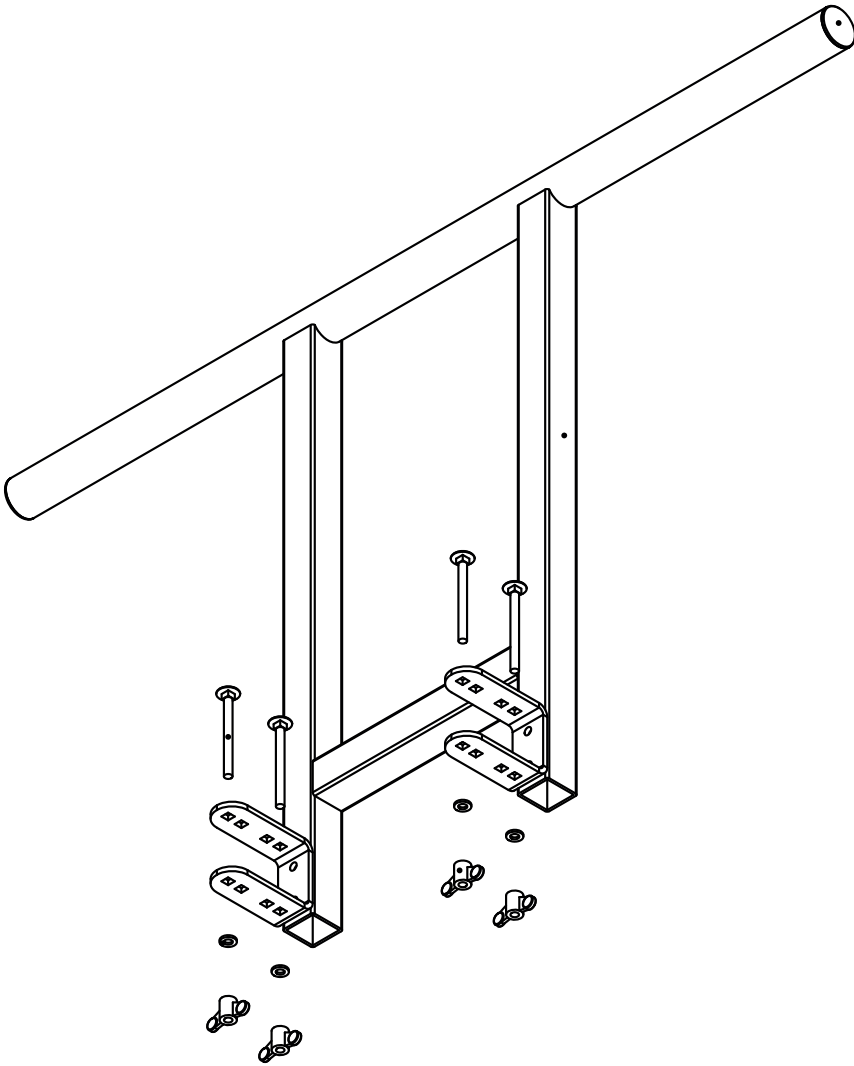

Fig. Installation of the Transport Bracket on the bed foot end crossbar

17 Cleaning/Disinfection



WARNING!

Risk of injury due to accidental bed movement!

- ▶ Always disable the function buttons when cleaning between the undercarriage and mattress support platform.



CAUTION!

Material damage due to incorrect cleaning/disinfection!

- ▶ Do not use washing machines.
- ▶ Do not use pressure or steam cleaners.
- ▶ Follow the instructions and observe the dosages recommended by the manufacturer.
- ▶ Ensure that disinfectants are selected and applied exclusively by qualified hygiene experts.
- ▶ **Check if used cleaning agents and disinfectants are compatible with materials that the product consists of! For information see the following table.**

BED COMPONENTS THAT ARE INTENDED TO BE CLEANED	MATERIALS (SURFACES OF THE MENTIONED BED COMPONENTS)	
Do not clean what is not mentioned in this column!	Competent user is responsible for check if used cleaning agents and disinfectants are compatible with mentioned materials!	
Head board and foot board	Polypropylene (PP)	
Head siderails and foot siderails	Polypropylene (PP)	
Mattress support platform covers (Backrest)	Polypropylene (PP)	version with x-ray cassette holder: High Pressure Laminate (HPL)
Mattress support platform covers (Thighrest, Calfrest)	Polypropylene (PP)	
Seat section	Lacquered steel	
Castors	Polyurethane (PUR) + Polypropylene (PP)	
Castor control levers	Polyamide (PA6) + Lacquered steel	
Frame of the mattress support platform	Lacquered steel	
Columns	Oxidized aluminium alloy	
Undercarriage cover	Acrylonitrile butadiene styrene (ABS)	
Corner covers	Polypropylene (PP)	
Corner bumpers	Polypropylene (PP)	
Keyboards (Attendant Control Panel, Handset, control elements integrated in the siderails)	Polyethylene terephthalate (PET)	
CPR levers	Lacquered steel	
Labels	Polyethylene terephthalate (PET)	
Accessory rail	Polyoxymethylene (POM) + Lacquered steel	
Actuators	Polyamide (PA6) + Aluminium (Al)	
Decors (head board, foot board, head siderails, foot siderails)	Acrylonitrile butadiene styrene (ABS)	
Mobi-Lift® handles	Polyamide (PA66) + Lacquered steel	
Foot controllers	Acrylonitrile butadiene styrene (ABS) + rubber + Lacquered steel	

For safe and gentle cleaning:

- ▶ Do not use any strong acids or bases (optimum pH range 6 - 8).
- ▶ Exclusively use detergents that are suitable for cleaning medical equipment.
- ▶ Do not use abrasive powders, steel wool, or other materials and cleaning agents that might damage the mattress replacement system.
- ▶ Never use any corrosive or caustic detergents.
- ▶ Never use detergents that deposit calcium carbonate.
- ▶ Never use detergents with solvents that might affect the structure and consistency of the plastics (benzene, toluene, acetone, etc.).
- ▶ Clean electrical components carefully and allow them to dry completely.
- ▶ Do not immerse control unit in water or steam-clean it.
- ▶ Observe local directives regarding infection control.
- ▶ Make sure any cleaning agent used is approved by:
 - the facility in which the mattress replacement system is to be used.
 - by competent authority of the country in which the mattress replacement system is to be used.

17.1 Cleaning (Eleganza 4)

Prepare for cleaning as follows:

- ▶ Put the mattress support platform in the highest position.
- ▶ Adjust the back and thigh rests so that the reverse sides are accessible.
- ▶ Disable the function buttons on the control elements using the Attendant Control Panel.
- ▶ Disable the foot controls using the Attendant Control Panel.
- ▶ Disconnect the bed from the mains.
- ▶ Move the bed to the location where it will be cleaned.
- ▶ Lock the brakes on the bed.

17.1.1 Daily Cleaning

Clean the following bed parts:

- All control elements for adjusting the bed
- All handles
 - CPR release handle
- Bed ends
- Siderails (in highest position)
- Freely accessible mattress surface
- Mobi-Lift®
- Accessory rails

17.1.2 Cleaning before Changing Patients

Clean the following bed parts:

- All control elements for adjusting the bed
- All handles
- CPR release handle
- Bed ends
- Siderails (in highest position)
- Freely accessible mattress surface
- Mobi-Lift®
- Accessory rails
- All plastic mattress support platform covers
- Plastic undercarriage covers
- Telescopic columns
- Mattress on all sides
- Freely accessible metal parts of mattress support platform
- Cable ducts
- Lifting pole sleeve fitting
- Infusion stand sleeve fitting
- Bumpers
- Castors
- Brakes

17.1.3 Complete Cleaning and Disinfection

Clean the following bed parts:

- All control elements for adjusting the bed
- All handles
- CPR release handle
- Bed ends
- Siderails (in highest position)
- Freely accessible mattress surface
- Mobi-Lift®
- Accessory rails
- All plastic mattress support platform covers
- Plastic undercarriage covers
- Telescopic columns
- Mattress on all sides
- Freely accessible metal parts of mattress support platform
- Cable ducts
- Lifting pole sleeve fitting
- Infusion stand sleeve fitting
- Bumpers
- Castors
- Brakes
- Interior parts (accessible after removing mattress support platform covers)

18 Troubleshooting



DANGER!

Risk of mortal injury due to electric shock!

- ▶ If a fault occurs, have the electric motor, power box or other electrical parts repaired by qualified personnel exclusively.
- ▶ Do not open the protective covers of the electric motor or the power box.

Error/Fault	Cause	Solution
Adjusting with position buttons not possible	GO Button was not pressed	Press the GO button.
	Function disabled on Attendant Control Panel	Enable disabled function.
	Actuators have no power Defective actuators Defective accumulator	Check the mains connection. Notify the service department.
	Mains Plug inserted incorrectly	Insert the Mains Plug correctly.
	Faulty Power Source	Notify the service department.
	Faulty Control Element	Notify the service department.
Faulty Mattress support platform Height/Tilt Adjustment	Obstacle on the undercarriage cover	Remove the obstacle.
	Function disabled on Attendant Control Panel	Enable disabled function.
	Actuators have no power Defective actuators Defective accumulator	Check the mains connection. Notify the service department.
	Mains Plug inserted incorrectly	Insert the Mains Plug correctly.
	Faulty Power Source.	Notify the service department.
	Faulty Control Element.	Notify the service department.
Lowering Backrest from the upright position not possible	Obstacle under the Backrest or in the drive mechanism.	Remove the obstacle
	CPR Release Handle is defective	Notify the service department.
Adjusting Siderails not possible	Obstacle in the Siderail Release Mechanism	Remove the obstacle.
	Siderail Release Mechanism is defective.	Notify the service department.
Faulty brakes	Obstacle blocking brakes mechanically	Remove the obstacle.
	The brake mechanism is defective	Notify the service department

19 Maintenance



WARNING!

Risk of injury when working on the bed!

- ▶ Ensure that the bed is disconnected from the mains power prior to installation, putting into service, maintenance and deinstallation.
- ▶ Ensure that the castors are locked prior to installation, putting into service, maintenance and deinstallation.



WARNING!

Risk of injury due to defective bed!

- ▶ Have a defective bed repaired immediately.
- ▶ If the defect cannot be repaired, do not use the bed.



CAUTION!

Material damage due to incorrect maintenance!

- ▶ Ensure that maintenance is performed exclusively by manufacturer's customer service or by authorised service personnel certified by the manufacturer.
- ▶ If the defect cannot be repaired, do not use the bed.

LINET ® recommends attaching the maintenance plaque to the bed.

19.1 Regular maintenance

- ▶ Check regularly movable parts for wear.
- ▶ Perform regularly visual check of the product (with delivery note if necessary).
- ▶ Ask service department of the manufacturer for addition of the original spare parts if some product parts are missing.
- ▶ Ask service department of the manufacturer for replacement of any damaged product parts by the original spare parts.
- ▶ Check that the accumulator is working properly. Disconnect the bed from the mains power to check signalisation of accumulator indicator according to the instructions for use.
- ▶ Have the accumulator replaced if it is not working properly.
- ▶ Check regularly that all accessories are working properly.
- ▶ Replace damaged accessories immediately.

19.2 Spare Parts

The serial label is located on the frame of the mattress support platform. The serial label contains information for claims and ordering replacement parts.

Information about spare parts is available from:

- Manufacturer's customer service
- Sales department

19.3 Safety Technical Checks



WARNING!

Risk of injury due to incorrect safety technical checks!

- ▶ Ensure that safety technical checks are performed exclusively by manufacturer's customer service or by authorised service personnel certified by the manufacturer.
- ▶ Ensure that the safety technical checks are recorded in the service and maintenance log.

Safety technical check of the medical bed must be performed at least once every 12 months.

The procedure for performing the safety technical check is stipulated in EN 62353:2014.

NOTE On request, the manufacturer will provide service documentation (e.g. circuit diagrams, component part lists, descriptions, calibration instructions etc.) for service personnel for the repair of ME equipment designated by the manufacturer as repairable by service personnel.

20 Disposal

20.1 Environment Protection

The company LINET® is aware of the importance of environmental protection for future generations. Within this company the environmental management system is applied in accordance with the internationally agreed standard ISO 14001. The compliance with this standard is annually tested by the external audit executed by an authorised company. Based on the Directive No. 2002/96/EC (Directive **WEEE** - Waste, Electric and Electronic Equipments) the company LINET, s. r. o. is registered in the List of Electric and Electronic Equipment Producers (**Seznam výrobců elektrozařízení**) on the Ministry of the Environment of the Czech Republic (Ministerstvo životního prostředí).

Materials used in this product are not environmentally hazardous. LINET® products meet valid requirements of national and European legislation in the areas of **RoHS** and **REACH**, so they do not contain any prohibited substances in excess quantities. None of the wooden parts is made of tropical wood (such as mahogany, rosewood, ebony, teak etc.) or made of timber from the Amazon region or from similar rainforests. Product noise (sound pressure level) meets requirements of the regulations for the protection of public health against undesirable effects of noise and vibration in protected interior spaces of buildings (according to standard IEC 60601-2-52). Used packaging materials are in accordance with requirements of the Packaging Act (**Zákon o obalech**). For disposal of packaging materials after installation of products contact your sales representative or manufacturer's customer service about the possibility of a free take-back of packaging through an authorized company (more details on www.linnet.cz).

20.2 Disposal

The main objective of the obligations arising from the European Directive No. 2012/19/EU on Waste, Electric and Electronic Equipments (nationally regulated in Act No. 185/2001 Coll. as amended. On Waste and in Decree of the Ministry of the Environment No. 352/2005 Coll. as amended), is to increase the re-use, material recovery and recovery of electric and electronic equipment at the required level, thereby avoiding the production of waste and thereby avoiding the possible harmful effects of hazardous substances contained in electric and electronic equipment on human health and the environment. LINET® electric and electronic equipments that have a built-in battery or accumulator are designed so that the used batteries or accumulators can be safely removed by LINET® qualified service technicians. There is an information about its type on the built-in battery or accumulator.

20.2.1 Within Europe

To dispose of the electric and electronic equipment:

- ▶ The electric and electronic equipment must not be disposed of as household waste.
- ▶ Dispose of this equipment at designated collection points or take-back points.

To dispose of the other equipment:

- ▶ The equipment must not be disposed of as household waste.
- ▶ Dispose of this equipment at designated collection points or take-back points.

LINET® participates in a collective system with take-back company REMA System (see www.remasystem.cz/sberna-mista/). By bringing electric and electronic equipment to a take-back point, you participate in recycling and you save primary raw material resources while protecting your environment from effects of unprofessional disposal.

20.2.2 Outside Europe

- ▶ Dispose of the product or its components in accordance with local laws and regulations!
- ▶ Hire an approved waste disposal company for disposal!

21 Warranty

LINET® will only be held responsible for the safety and reliability of products that are regularly serviced, maintained and used in accordance with the safety guidelines.

Should a serious defect arise that cannot be repaired during maintenance:

- ▶ Do not continue to use the bed.

This product is covered by a 24-month warranty from the date of purchase. The warranty covers all material and manufacturing-related failures and errors. Failures and errors caused by incorrect use and external effects are not covered. Justified complaints will be fixed free of charge during the warranty period. Proof of purchase, with the date of purchase, is required for all warranty service. Our standard terms and conditions apply.

22 Standards and Regulations

Applied norms are stated on Declaration of Conformity.

The manufacturer adheres to a certified quality management system in compliance with the following standards:

- ISO 9001
- ISO 14001
- ISO 13485
- MDSAP (Medical Device Single Audit Program)